

Indian Standard
ELECTRIC TABLE TYPE FANS AND REGULATORS
(~~Third~~ Fourth Revision)

0. FOREWORD

0.0 This Indian Standard (Third Revision) was adopted by the Indian Standards Institution on 31 August 202X, after the draft finalized by the Electric Fans Sectional Committee had been approved by the Electro technical division Council.

~~**0.1** This standard was originally published in 1955 and was subsequently revised in 1960, and 1967 and 1979. The present revision has been undertaken to incorporate:~~

0.1 Following are the significant changes in this revision:

- a. Reference to IS 302 (Pt 2/ Sec 80) has been incorporated in relevant clauses.
 - b. Maximum rated voltage has been specified in the Scope
 - c. Under General and safety requirements, provision for BLDC motor, Additional features such as IOT, remotes, LEDs etc has been added.
 - d. Wherever for components ISS are under mandatory certification of BIS, conformity to the standard has been made a requirement.
 - e. Marking- provisions of IS 302 (Pt 2/ Sec 80) and IS 302-1 also incorporated. BIS certification marking as per latest Act has been incorporated.
 - f. Safety requirements which are also a requirement of IS 302 (Pt 2/ Sec 80) have been removed to avoid repetition.
 - g. All cross referred Standards have been updated.
 - h. Accuracy for temperature rise test shall be $\pm 0.5^{\circ}\text{C}$.
 - i. Wire diameter shall be 1.30mm minimum
 - j. Supply cord length shall be 1.8m minimum.
- ~~→ Additional safety requirements, such as leakage current, protection against electric shock, mechanical strength, etc;~~
- ~~→ Guidance regarding constructional aspects, effecting safety; and~~
- ~~→ Experience gained in the field since publication of the last revision~~

~~**0.50.2** Reference have been made in this standard regarding safety requirements and test methods to ~~IS- IS 302 (Part 2/Sec 80) 302-202X*~~ which is a necessary adjunct to this standard. Should, however, any deviations exist between IS: ~~302 (Part 2/Sec 80) 302-202X*~~ and those of this standard, the provisions of the latter shall apply.~~

~~**0.60.3** For the purpose of deciding whether a particular requirement of this standard is complied with, the final value, observed or calculated expressing the result of a test shall be rounded off in accordance with IS : ~~2-1960~~[†]. The same as that of the specified value in this standard.~~

1. SCOPE

~~**1.1** This standard specifies the performance requirements and methods of tests for single phase 50 Hz capacitor type and non-capacitor type ac table type fans as well as dc table type fans up to and including 250 V for household and similar purposes, including the associated speed regulators.~~

~~**1.2** The requirements for safety have been covered in IS 302 (Part 2/Sec 80).~~

~~**2.0** This standard specifies the requirements and methods of tests for capacitor type and non-capacitor~~

~~**2.1** type ac table type fans as well as dc table type fans, including the associated speed regulators.~~

~~**2.2** *General and safety requirements for household and similar electrical appliances (*fifth revision*).~~

~~**2.3** † Rules for rounding off numerical values (*revised*).~~

Formatted: Font: (Default) Times New Roman, 12 pt

Formatted: Font: (Default) Times New Roman, 12 pt

Formatted: Indent: Left: 2.37 cm, Numbered + Level: 1 + Numbering Style: a, b, c, ... + Start at: 1 + Alignment: Left + Aligned at: 1.27 cm + Indent at: 1.9 cm

Formatted: Font: (Default) Times New Roman, 12 pt, Bold

Formatted: Normal, Centered, Indent: Left: 0 cm

Formatted: Indent: Left: 0.63 cm, No bullets or numbering

32 TERMINOLOGY

3.02.0 For the purpose of this standard, definitions given in IS 302 (Part 2/Sec 80), and the following definitions shall apply. ~~For the purpose of this standard, the following definitions shall apply.~~

3.12.1 **Table Type Fan** – A propeller-bladed fan having two or more blades, directly driven by an electric motor, and intended for use with free inlet and outlet. It may be a table fan or a bracket-mounted fan for wall or ceiling mounting.

3.22.2 **Rating** – A statement of the operating characteristics assigned to the fan by the manufacturer when tested in accordance with 10.

3.32.3 **Rated Voltage** – The voltage assigned to the fan by the manufacturer and marked on it.

3.42.4 **Rated Voltage Range** - The voltage range assigned to the fan by the manufacturer expressed by its upper and lower limits and marked on it.

3.52.5 **Rated Frequency** – In the case of ac fans, the frequency assigned to the fan by manufacturer and marked on it.

~~IS 555—202X~~

3.62.6 **Rated Frequency Range** – The limits of frequency assigned to the fan by manufacturer and marked on it.

3.72.7 **Rated Speed** - The rotational speed specified by the manufacturer at which the fan develops the specified output at the rated frequency and rated voltage.

3.82.8 **Cooling Air Temperature** – The temperature of the surrounding atmosphere in which the fan operates.

3.92.9 **Service Value** – The air delivery in m³/min divided by electrical power input to the fan in watts at the voltage and frequency specified for the test. In the event of the fan comprising an oscillating mechanism, the electrical input in watts is measured with the fan under normal full speed conditions, that is with oscillating mechanism in action, whereas the air delivery is determined with the oscillating mechanism out of action.

3.102.10 **Blade Sweep** - The diameter of the circle traced out by the extreme tips of the fan blades.

3.112.11 **Size of Fan** – The blade sweep in millimeters.

3.122.12 **Plane of Fan Blades** – The middle plane of the solid of revolution traced out by the fan blades.

3.132.13 **Plane of Anemometer Vanes** – The middle plane of the solid of revolution traced out by the vanes of the anemometer.

~~3.14.2.14~~ **Test Plane** – the vertical plane containing the plane of the anemometer vanes.

~~3.15.2.15~~ **Types of Enclosures of Motors and Regulators**

~~3.15.42.15.1~~ **Totally Enclosed Type** – An enclosure which prevents circulation of air between the inside and outside of the case, but not necessarily 'airtight'.

~~3.15.22.15.2~~ **Ventilated Type** – An enclosure in which the ventilation is not materially obstructed, while the live parts are protected mechanically against accidental or careless contact.

2.16 Mounting - The mounting of a fan is the means of attaching the fan system (motor and blades) to its base.

2.17 Clamping Device – A means by which any positioning device, that is swivel, trunnion, oscillating mechanism, etc, may be held in the desired position.

2.18 Insulation

2.18.1 Basic Insulation – Denotes the insulation applied to live parts to provide basic protection against electric shock.

Note 1 – Base insulation does not necessarily include insulation used exclusively for functional purposes.

~~IS 555—202X~~

Note 2 – The insulating properties of lacquer, enamel, ordinary paper, cotton, oxide film on metal parts, beads and sealing compound shall not be relied upon to give the required protection against accidental contact with live parts.

2.18.2 Supplementary Insulation – Denotes an independent insulation applied in addition to the basic insulation, in order to ensure protection against electric shock in the event of a failure of the basic insulation.

2.18.3 Double Insulation – Denotes insulation comprising both basic insulation and supplementary insulation.

2.18.4 Reinforced Insulation – Denotes a single insulation system applied to live parts, which provides a degree of protection against electric shock equivalent to double insulation under the conditions specified in this standard.

Note – The term 'insulation system' does not imply that the insulation must be one homogeneous piece. It may comprise several layers which cannot be tested singly as supplementary or basic insulation.

2.19 Class I Type Fans and Regulators - Denotes the one in which protection against electric shock does not rely on basic insulation only, but which also includes an additional safety precaution in that accessible conductive parts are connected to the protective earthing conductor in the fixed wiring of the installation

in such a way that accessible conductive parts cannot become live in the event of a failure of the basic insulation.

NOTE 1 – Class I type may have parts with double insulation or reinforced insulation, or parts operating at safety extra-low voltage.

NOTE 2 – For fans and regulators intended for use with a flexible cord or cable, this provision includes a protective conductor as part of the flexible cord or cable.

2.20 Class II Type Fans and Regulators – Denotes the one in which protection against electric shock does not rely on basic insulation only, but in which additional safety precautions, such as double insulation or reinforced insulation, are also provided, there being no provision for protective earthing or reliance upon installation conditions.

Formatted: Indent: Left: 1.9 cm, First line: 0 cm

Formatted: Indent: Left: 0.63 cm, First line: 0 cm

Formatted: Indent: Left: 0.63 cm

~~IS 555—202X~~

Such fans and regulators may be one of the following types:

- a) Having a durable and substantially continuous enclosure of insulating material which envelops all metal parts, with the exception of small parts, such as name-plates, screws and rivets, which are isolated from live parts by insulation at least equivalent to reinforced insulation; such an appliance is called an insulation-encased class II appliance.
- b) Having a substantially continuous metal enclosure in which double insulation is used throughout except for those parts where reinforced insulation is used, because the application of double insulation is manifestly impracticable; such an appliance is called a metal-encased class II type.
- c) One which is a combination of the types (a) and (b).

NOTE 1 – The enclosure of an all-insulated Class II type may form a part or the whole of the supplementary insulation or of the reinforced insulation.

NOTE 2 – If fans and regulators, with double insulation and/or reinforced insulation throughout, have an earthing terminal or earthing contact, they are considered to be of Class I.

NOTE 3 – Class II type may have parts operating at safety extra-low voltage.

2.21 Type Tests – Tests carried out to prove conformity with the requirements of this standard. These are intended to prove general qualities and design of a given type of fan.

2.22 Routine Tests – Test carried out on each fan to check the essential requirements which are likely to vary during production.

2.23 Acceptance Test - Tests carried out on samples selected from a lot for the purpose of verifying the acceptability of the lot.

2.23.1 Lot – All fans of the same type, grade, category and rating, manufactured by the same factory during the same period, using the same process and materials.

IS 555 – 202X

3 DESIGN & GENERAL REQUIREMENTS

3.1 The fans shall comply with the following requirements in addition to those given in IS 302 (Part 2/Sec 80).

3.2 Stampings

The stampings of fan motors shall be made from electrical steel sheet conforming to IS 648 or IS 3024. Alternate material to be used can be electrical grade cold rolled close annealed (CRCA) semi processed after decarburization.

3.3 Blades

Fan blades shall be fitted with two or more well balanced blades made from metal or any other suitable rigid material. The blades and motors shall be securely fixed so that they do not become loose during its operation.

3.4 Bearings

The instruction for proper lubrication of bearings shall be furnished by the manufacturer in the instruction sheet. Proper types of bearings should be used to ensure a reasonable amount of silent operation

3.5 Brushless DC Motor

High efficiency fans may be developed using any motor and control technology provided they meet the clauses of this standard. Brushless DC motor technology may be offered with electronic controllers that use sensors or are sensorless. The motor design may be PMDC or PMSM or any other concept that can meet the requirements of this standard.

3.6 Enclosure

Formatted: Font: Bold

Formatted: Font: Bold

Motors and regulators of table fans shall have enclosures corresponding to degree of protection IP 21, IP 22 or IP 44 according to IS/IEC 60529. The enclosures of all-insulated fans may form part or whole of the supplementary or reinforced insulation.

3.7 Guard

Fans, other than those with fixable blades, shall have a suitable robust guard to provided, in normal use, adequate protection against personal injury as far as possible. If a close mesh guard is provided, the nominal diameter of the wires of the guard shall not be less than 1.30 mm and the center distance between the wires shall not exceed 10 mm. When the guards are in two pieces, positive locking arrangement to keep the two pieces together should be made.

3.8 Heat Resistance

No readily flammable material shall be used in the construction of a fan and a regulator. Moulded parts, if used, shall be of such materials as will withstand the maximum temperature attained in the adjacent component parts.

3.9 Moisture Resistance

Only suitable material which is resistant to moisture shall be used.

3.10 Lifting Handle

All portable fans shall be provided with a suitable robust lifting handle, securely fixed.

3.11 Supply Cord

Unless specifically agreed otherwise between the supplier and the user, a minimum length of 1.8m (from the point where it comes out) of flexible cord of the sheathed type conforming to IS 9968 (Part I) or IS 694 suitably connected to the terminals or contacts, shall be supplied with each fan. For fans intended to be earthed, a three-core cable shall be supplied with the earthed core connected to the earthing terminal or contact provided on the fan. For fans with double or reinforced insulation a two core cord shall be used. For portable fans with functional insulation, 3 pin plug conforming to IS 1293 with cord shall be used for supply connection.

3.12 Cord Grip

All fans shall be provided with a cord grip capable of passing the tests specified in 10.14 so that the conductors are protected from strain, including twisting and abrasion.

3.12.1 The cord grip shall preferably be of insulating material or, if of metal, be adequately insulated.

3.12.2 On fans with double or reinforced insulation, the cord grip shall be so designed that the fixable cord does not come into contact with the Fixing screws, if they are accessible, or in contact with accessible, metal parts. The cord grip shall be suitable for the different types of cords which may be attached to the fan.

3.13 All fans and regulators with basic insulation only shall be provided with an earthing terminal or contact, which shall be indelibly marked with the symbol \perp the earthing terminal or contact shall not be used for any other purpose.

3.14 Protection Against Direct Contact — In the assembled fan and regulator, live parts shall not be accessible to the standard test finger (see IS 1401). In the case of a double insulated fan, both basically insulated parts and live parts shall not be accessible to the standard test finger.

3.15 Method of Mounting — The mounting may be one of the following types:

- a) Rigid — The direction of draught is changed only by changing the position of the fan.
- b) Semi-rigid — A trunnion or swivel arrangement, or both, incorporated in the mounting so that the direction of the draught may be altered to suit the requirements.
- c) Oscillating — Suitable device is provided by which the direction of the axis of the draught is changed automatically and continuously in one plane.
- d) Double-oscillating or Gyrostatic — Suitable device is provided by which the direction of the axis of the draught is changed automatically and continuously in more than one plane.

3.15.1 Clamping Devices — All clamping devices, where provided, shall be of a strong and simple design. They shall be so arranged that the mechanism may be positively adjusted without there being undue risk of working loose.

3.16 Capacitors — Capacitors, if any, shall be easily replaceable and placed at sufficient distance from the windings, so that its maximum safe working temperature is not exceeded. Capacitors shall be clearly marked with the maximum safe working temperature, and the corresponding voltage and capacitance. Capacitors shall comply with IS : 1709

3.17 Handles, knobs, grips and the like shall be fixed in a reliable manner so that they will not work loose in normal use if loosening results in a hazard.

3.18 Components, which may require replacement such as capacitor, shall be suitably fixed to enable easy replacement when necessary.

3.19 It shall not be possible to remove parts, which ensure a required degree of protection against moisture, without the aid of a tool.

3.20 Supplementary insulation and reinforced insulation shall be so designed or protected that they are not likely to be impaired by deposition of dirt, or by dust resulting from wear of the parts within the fan to such an extent that creepage distances or clearances are reduced below the values specified in **CI 29 IS 302 (Pt 2/ Sec 80)**.

3.21 Parts of natural or synthetic rubber, used as supplementary insulation in class II fans, shall be resistant to aging and shall be so arranged and dimensioned that creepage distances are not reduced below values given in **CI 29 IS 302 (Pt 2/ Sec 80)** even if cracks occur.

3.22 Current carrying parts and other metal parts, the corrosion of which might result in hazard, shall be resistant to corrosion under normal conditions of use.

NOTE — Attention must be paid to the compatibility of the materials of terminals and terminations and to the effect of heating. Stainless steel and similar corrosion-resistant alloys and plated steel are considered to be satisfactory for the purpose of the requirement.

3.23 Radio and television interference suppressors, if any, shall be so fitted that they are adequately protected against mechanical damage when the fan is in its normal position of use.

Note- Fans and regulators as per this Standard may incorporate additional application features such as IOT, remote, Air purifier, LED etc provided they comply with the relevant safety standards.

4 SIZE, SPEEDS AND TYPES

4.1 The sizes, number of speeds and types of fans shall be as given in Table 1.

TABLE 1 SIZE, NUMBER OF SPEEDS AND TYPES
(Clause 3.1)

<u>SIZE OF FAN</u>	<u>NUMBER OF SPEEDS,</u>	<u>TYPE</u>
	<u>Min</u>	
<u>(1)</u>	<u>(2)</u>	<u>(3)</u>
<u>Mm</u>		
200	1	No-oscillating
250	1	Oscillating or non-oscillating
300	2	
400	3	

NOTE – Sizes of fans specified above are subject to a tolerance of ± 5 mm.

5 RATED VOLTAGE

The preferred voltage for table type fans shall be 230 and 240 V, single phase ac or 220 V dc.

6 RATED FREQUENCY

6.1 The rated frequency shall be the standard frequency of 50 Hz.

NOTE- Nevertheless, fans made for other frequencies shall be considered to comply with the specification, provided they do so in all other relevant respects.

7 MARKING

7.1 Each fan shall be indelibly marked with the following information in addition to those given in clause 7 of IS 302 (Part 2/Sec 80) ~~Each fan shall be indelibly marked with at least the following information:~~

- a) Manufacturer's name, trade name of fan (if any), and number;
- b) Rated voltage(s) or voltage range;
- c) Type of fan ac or dc;
- d) Frequency or frequency range of power supply, if of ac;
- e) Input in watts (with oscillating mechanism at the highest speed setting of regulator);
- f) Size of fan; and
- g) Country of manufacture.

NOTE 1 — The trade name, voltage and the size of the fan shall be marked on the associated regulator, if supplied separately.

NOTE 2 — Item (a) and (g) (manufacturer's name, etc. and country of manufacture) may not be marked if specifically desired by the purchaser.

7.2 In the case of a fan and a regulator provided with an earthing terminal or contact, it shall be indelibly marked with the symbol \perp .

97.3 For additional information that the manufacturer may be requested to supply (see Appendix A).

97.4 BIS Certification Marking

Electric table type fans may also be marked with the Standard Mark.

7.4.1 The use of the standard mark is governed by the provisions of Bureau of Indian Standards Act, 2016 and the Rules and Regulations made thereunder. The details of the conditions under which the licence for use of the standard mark may be granted to manufacturers or producers may be obtained from the Bureau of Indian Standards. Table type fans may also be marked with the ISI Certification Mark.

NOTE The use of the ISI Certification Mark is governed by the provisions of the Indian Standards Institution (Certification Marks) Act and the Rules and Regulations made thereunder. The ISI Mark on products covered by an Indian Standard conveys the assurance that they have been produced to comply with the requirements of that standard under a well defined system of inspection, testing and quality control which is devised and supervised by ISI and operated by the producer. ISI marked products are also continuously checked by ISI for conformity to that standard as a further safeguard. Details of conditions, under which a licence for the use of the ISI Certification Mark may be granted to manufacturers or processors, may be obtained from the Indian Standards Institution.

3— SIZE, SPEEDS AND TYPES

3.1 The sizes, number of speeds and types of fans shall be as given in Table 1.

TABLE 1 SIZE, NUMBER OF SPEEDS AND TYPES
(Clause 3.1)

SIZE OF FAN	NUMBER OF SPEEDS, Min	TYPE
(1)	(2)	(3)
Mm		
200	1	No oscillating
250	1	Oscillating or non-oscillating
300	2	
400	3	

NOTE Sizes of fans specified above are subject to a tolerance of ± 5 mm.

4— RATED VOLTAGE

6.1 The preferred voltage for table type fans shall be 230 and 240 V, single phase ac or 220 V dc (see IS : 585—1962*).

7— RATED FREQUENCY

7.1 The rated frequency shall be the standard frequency of 50 Hz.

NOTE Nevertheless, fans made for other frequencies shall be considered to comply with the specification, provided they do so in all other relevant respects.

8— DESIGN AND GENERAL CONSTRUCTION

8.1 Enclosures

Formatted: Outline numbered + Level: 1 + Numbering Style: 1, 2, 3, ... + Start at: 7 + Alignment: Left + Aligned at: 0 cm + Indent at: 0.74 cm

Formatted: Font: (Default) Times New Roman, 12 pt

Formatted: Outline numbered + Level: 1 + Numbering Style: 1, 2, 3, ... + Start at: 7 + Alignment: Left + Aligned at: 0 cm + Indent at: 0.74 cm

Formatted: Indent: Left: 1.27 cm, Outline numbered + Level: 2 + Numbering Style: 1, 2, 3, ... + Start at: 1 + Alignment: Left + Aligned at: 1.11 cm + Indent at: 1.75 cm, Tab stops: 1.75 cm, Left

Formatted: Normal, Indent: Left: 0 cm, Tab stops: 1.9 cm, Left

~~8.1.1 Motors and regulators of table fans shall have enclosures corresponding to degree of protection IP 21, IP 22 or IP 44 according to IS : 4691-1968†.~~

~~NOTE These correspond to ventilated or totally enclosed type.~~

~~8.1.2 The enclosures of all insulated fans may form part or whole of the supplementary or reinforced insulation.~~

~~6.2 Stampings Stampings of fan motors shall be made from electrical steel sheets (see IS: 648-1970‡, IS: 649-1963§ and IS : 3024-1965).~~

~~— *Voltages and frequency for ac transmission and distribution systems (revised).~~

~~— †Degrees of protection provided by enclosures for rotating electrical machinery.~~

~~— ‡Specification for non-oriented electrical steel sheets for magnetic circuits (second revision);~~

~~— §Methods of testing steel sheets for magnetic circuits of power electrical apparatus (revised).~~

~~— †Specification for electrical steel sheets (oriented).~~

~~6.3 Blades Fans shall be fitted with two or more well balanced blades made from metal or other suitable material. The blades and blade carriers shall be securely fixed so that they do not loosen in operation.~~

~~6.4 Guard Fans, other than those with fixable blades, shall have a suitable robust guard to provided, in normal use, adequate protection against personal injury as far as possible. If a close mesh guard is provided, the nominal diameter of the wires of the guard shall not be less than 1.60 mm and the center~~

~~distance between the wires shall not exceed 10 mm. When the guards are in two pieces, positive locking arrangement to keep the two pieces together should be made.~~

~~6.5 Heat Resistance No readily flammable material shall be used in the construction of a fan and a regulator. Moulded parts, if used, shall be of such materials as will withstand the maximum temperature attained in the adjacent component parts.~~

~~6.6 Moisture Resistance Only suitable material which is resistant to moisture shall be used.~~

~~6.7 Bearing Instructions for proper lubrication of bearings shall be furnished by the manufacturer. Proper types of bearings should be used to ensure a reasonable amount of silent operation.~~

~~6.8 Lifting Handle All portable fans shall be provided with a suitable robust lifting handle, securely fixed.~~

~~6.9 Supply Cord Unless specifically agreed otherwise between the supplier and the user, a minimum length of 2 m (from the point where it comes out) of flexible cord of the sheathed type [see IS 434 (Part I) 1964* and IS : 694-1977] suitably connected to the terminals or contacts, shall be supplied with each fan. For fans intended to be earthed, a three core cable shall be supplied with the earthed core connected to the earthing terminal or contact provided on the fan. For fans with double or reinforced insulation a two core cord shall be used.~~

~~6.10 Cord Grip All fans shall be provided with a cord grip capable of passing the tests specified in 10.14 so that the conductors are protected from strain, including twisting and abrasion.~~

~~6.10.1 The cord grip shall preferably be of insulating material or, if of metal, be adequately insulated.~~

~~6.10.2 On fans with double or reinforced insulation, the cord grip shall be so designed that the fixable cord does not come into contact with the~~

Formatted: Outline numbered + Level: 2 + Numbering Style: 1, 2, 3, ... + Start at: 3 + Alignment: Left + Aligned at: 0 cm + Indent at: 0.63 cm

Formatted: Outline numbered + Level: 2 + Numbering Style: 1, 2, 3, ... + Start at: 3 + Alignment: Left + Aligned at: 0 cm + Indent at: 0.63 cm, Tab stops: 1.75 cm, Left + Not at 1.27 cm

Formatted: Tab stops: 1.75 cm, Left + Not at 1.27 cm

Formatted: Outline numbered + Level: 2 + Numbering Style: 1, 2, 3, ... + Start at: 3 + Alignment: Left + Aligned at: 0 cm + Indent at: 0.63 cm, Tab stops: 1.75 cm, Left + Not at 1.27 cm

Formatted: Outline numbered + Level: 2 + Numbering Style: 1, 2, 3, ... + Start at: 3 + Alignment: Left + Aligned at: 0 cm + Indent at: 0.63 cm

Formatted: List Paragraph, Outline numbered + Level: 2 + Numbering Style: 1, 2, 3, ... + Start at: 3 + Alignment: Left + Aligned at: 0 cm + Indent at: 0.63 cm

^aSpecification for rubber-insulated cables: Part 1 with copper conductors (revised).

[†]Specification for PVC-insulated cables for working voltages up to and including 1 100 V (second revision).

Fixing screws, if they are accessible, or in contact with accessible, metal parts. The cord grip shall be suitable for the different types of cords which may be attached to the fan.

6.11 All fans and regulators with basic insulation only shall be provided with an earthing terminal or contact, which shall be indelibly marked with the symbol — the earthing terminal or contact shall not be used for any other purpose.

6.12 **Protection Against Direct Contact** — In the assembled fan and regulator, live parts shall not be accessible to the standard test finger (see IS : 1401-1970^{*}). In the case of a double insulated fan, both basically insulated parts and live parts shall not be accessible to the standard test finger.

IS 555 — 202X

6.13 **Method of Mounting** — The mounting may be one of the following types:

- a) Rigid — The direction of draught is changed only by changing the position of the fan.
- b) Semi rigid — A trunnion or swivel arrangement, or both, incorporated in the mounting so that the direction of the draught may be altered to suit the requirements.
- c) Oscillating — Suitable device is provided by which the direction of the axis of the draught is changed automatically and continuously in one plane.
- d) Double oscillating or Gyrostatic — Suitable device is provided by which the direction of the axis of the draught is changed automatically and continuously in more than one plane.

6.13.1 Clamping Devices — All clamping devices, where provided, shall be of a strong and simple design. They shall be so arranged that the mechanism may be positively adjusted without there being undue risk of working loose.

6.14 **Capacitors** — Capacitors, if any, shall be easily replaceable and placed at sufficient distance from the windings, so that its maximum safe working temperature is not exceeded. Capacitors shall be clearly marked with the maximum safe working temperature, and the corresponding voltage and capacitance. Capacitors shall comply with IS : 1709-1960[†]. 6.15 Handles, knobs, grips and the like shall be fixed in a reliable manner so that they will not work loose in normal use if loosening results in a hazard.

^{*}Specification for accessibility test probes (first revision).

[†]Specification for fixed capacitors for fans.

6.16 Components, which may require replacement such as capacitor, shall be suitably fixed to enable easy replacement when necessary.

6.17 It shall not be possible to remove parts, which ensure a required degree of protection against moisture, without the aid of a tool.

6.18 Supplementary insulation and reinforced insulation shall be so designed or protected that they are not likely to be impaired by deposition of dirt, or by dust resulting from wear of the parts within the fan to such an extent that creepage distances or clearances are reduced below the values specified in 7.5.

~~6.19~~ Parts of natural or synthetic rubber, used as supplementary insulation in class II fans, shall be resistant to aging and shall be so arranged and dimensioned that creepage distances are not reduced below values given in 7.5 even if cracks occur.

~~6.20~~ Current carrying parts and other metal parts, the corrosion of which might result in hazard, shall be resistant to corrosion under normal conditions of use.

~~NOTE—Attention must be paid to the compatibility of the materials of terminals and terminations and to the effect of heating. Stainless steel and similar corrosion-resistant alloys and plated steel are considered to be satisfactory for the purpose of the requirement.~~

~~6.21~~ Radio and television interference suppressors, if any, shall be so fitted that they are adequately protected against mechanical damage when the fan is in its normal position of use.

IS 555—202X

8. GENERAL AND SAFETY REQUIREMENTS

Fans and regulators shall comply with the requirements of Cl 8 to 32 of IS 302 (Part 2/Sec 80) in addition to the following. Should however, any deviation exist between IS 302-1 and this standard, the provisions of the latter shall apply.

8.1 Electrical Insulation Under Normal Operating Conditions

8.1.1 The electrical insulation of the fans and regulators at operating temperature shall be adequate and the leakage current in normal use shall not be excessive.

8.1.1.1 When measured according to the method specified in 10.8.1 the insulation resistance shall not be less than 2 M Ω .

8.1.1.2 Leakage current (see 10.5):

a) For class I type fans and regulators the leakage current which may flow from the live parts to the accessible parts and metal foil on external insulating material connected together shall not exceed 300 μ A (peak), that is 210 μ A (rms).

b) For class II type fans and regulators the leakage current from live parts to the inner non-current carrying metal shall not exceed 300 μ A (peak), whereas the leakage current from the live parts to the metal foil wrapping (for all insulated fans and regulators) or the external metal and metal foil wrapping connected together (for double insulated fans and regulators) shall not exceed 60 μ A (peak), that is 42.5 μ A (rms).

8.1.13 The insulation is subjected for one minute to a voltage of substantially sine wave-form having a frequency of 50 Hz as given in 10.6.

8.2 Temperature-rise — The fan motor and regulator shall be tested at any cooling air temperature not exceeding 40°C, but whatever may be the value of this temperature, the permissible temperature-rise shall not exceed the values shown in Table 2.

TABLE 2 PERMISSIBLE LIMITS OF TEMPERATURE-RISE

SL. NO OF	PART OF MOTOR OR REGULATOR	TEMPERATURE-RISE			METHOD MEASUREMENT
		Class A Insulation	Class E Insulation	Class B Insulation	
(1)	(2)	(3)	(4)	(5)	(6)
		°C	°C	°C	
j)	Insulated windings of motors	60	75	85	Change of resistance
ii)	Insulated windings, if any, of regulator (with continuous running on any contact)	60	75	85	Change of resistance
iii)	External surfaces other than Metallic handles, likely to be Touched momentarily during normal usage	40	40	40	Thermometer
iv)	Metallic handles	20	20	20	Thermometer
v)	External surface of capacitors	45	45	45	Thermometer

NOTE 1 — The thermocouples, if used, should be applied only to external surfaces which may be reached by an ordinary thermometer.

NOTE 2 — The temperature-rise values given above are for fans normally made to this specification to work in cooling air temperatures not exceeding 40°C. Nevertheless, fans made to work in higher cooling air temperatures may be regarded as complying with this specification, provided the temperature-rise values are reduced corresponding to the increase in cooling air temperature. Such fans shall be specially marked.

8.3 Mechanical Endurance — The fan regulators shall be robust in construction and shall meet the requirements specified in 10.13.

8.4 Creepage Distances and Clearances — The relevant provisions of 29 of IS : 302 (Part 2/Sec 80) shall apply. NOTE — These provisions shall not be applicable to motor winding.

8.5 Finish — All the surfaces of both the fan motor with blades and regulator, if any, shall be of corrosion-resisting material or shall be suitably and durably protected against corrosion.

8.6 Insulating Materials — With the exception of resistance wires in regulators, windings of fans and regulators shall be insulated either with Class A, Class B or with Class E insulating materials which comply with the limits of temperature-rise specified in 8.2 and moisture resistance test specified in 10.12. The insulating materials are detailed in IS : 1271.

8.7 Speed Regulators

8.7.1 Speed regulators shall be capable of reducing the speed of the fan by at least 30 percent of the full speed at the test voltage and frequency specified for the test, except in the case of fans of the shaded pole type, where the speed reduction shall be not less than 20 percent. Fans shall be capable of running continuously on any of

the running positions of the regulator at the rated voltage or voltages (see 2.3) or within the whole rated voltage range (see 2.4), whichever is applicable.

8.7.2 The regulator for 300 mm and 400 mm size fans shall have an 'OFF' position preferably next to the lowest speed contact, and shall be provided with running positions as specified in 4.1. The speed difference at any running position shall not deviate by more than ± 50 percent from the ideal speed difference calculated on the basis of maximum and minimum speeds divided by the number of steps provided in the speed regulator.

NOTE — The following example illustrates the significance of this clause: Let the maximum speed of the fan be 1 200 rev/min and the minimum speed be 840 rev/min.

Then the ideal speed difference will be 180 rev/min (if 3 running positions are provided). The speed difference between any two running positions should be between 270 and 90 rev/min.

8.7.3 Where a regulator is provided with a capacitor not permanently connected across the motor terminals, provision shall be made so that the capacitor is discharged when the regulator is in the 'OFF' position.

8.7.4 The regulator handle or knob or push buttons shall either be of insulating material or, if of metal, shall be adequately insulated electrically and thermally so that its temperature-rise above ambient is limited to 20°C. All metallic parts associated with it shall be protected from accidental contact.

8.7.5 The regulator handle or knob shall be so placed that it may be safely and conveniently manipulated, and unless continuously variable, shall only rest in one of the regulating positions. The handle or knob shall be so designed that it does not become loose in use. The 'running' and 'OFF' positions of the regulator shall be distinctly and clearly marked and the indicator on the operating handle or knob shall correctly indicate the position of the regulator.

8.7.6 The regulators should have mechanical stops for the regulator moving contact to prevent accidental contact with the metallic body of the regulator in the event of forced over travel of the knob.

8.7.7 The mechanism of the regulator shall be so designed as to ensure positive contact at each running position. In the case of inductance type regulators, it is essential that no portion of the inductive winding should remain permanently short-circuited in any of the running positions.

8.8 Interchangeability — The motor of the fan of a particular size and model and its associated regulator and set of blades shall be interchangeable such that the performance of the fan keeps within specified limits (see 9).

8.9 Silent Operation — Precautions shall be taken in the manufacture of fans and regulators to ensure an reasonable degree of silence at all speeds.

NOTE — The need for specifying limits of noise levels (acoustical) of the fans is recognized. However, it has not been found possible to specify these limits at present on account of:

- a) dependency of these limits on the actual location of the fans;
- b) lack of data on the acceptable noise levels for different applications; and
- c) lack of agreed definition of noise level and method of evaluating the same. The criterion of noise level may, therefore, be subject to an agreement between the manufacturer and the purchaser.

8.10 Oscillating Mechanism

8.10.1 The number of oscillations (that is, complete to-and-fro movements) per minute at full speed shall be not less than four.

8.10.2 Whether the angular movement of the mechanism is variable or not, an angular movement of not less than 60° shall be available (see Fig. 1).

8.10.3 A device shall be provided to render the oscillating mechanism inoperative when desired. The method of operating the device should preferably be indicated. Means shall be provided to ensure that, when properly.

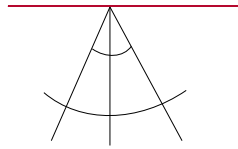

FIG. 1 ANGULAR MOVEMENT OF OSCILLATION

Installed, the fan is not stalled or overturned if the oscillating mechanism is impeded.

9. PERFORMANCE REQUIREMENT

9.1 The minimum air delivery and service value at test voltage and at full speed shall be as given in Table 3.

9.2 For compliance with requirements of this standard, the values of air delivery and service value shall not be less than those specified in Table 3. In case higher values of air delivery and service are declared by the manufacturer (see 7.3), the observed results, expressed as the percentage of the values declared by the manufacturer shall not be less than 90 percent of the declared values. The actual input when measured shall not exceed the declared value by more than 10 percent subject to the condition that the observed value shall in no case exceed the specified value given in Table 3

TABLE 3 MINIMUM AIR DELIVERY AND SERVICE VALUE FOR TYPE A FANS

(Class 9.1)

<u>FAN SIZE</u>	<u>TYPE</u>	<u>AIR DELIVERY</u>	<u>SERVICE VALUE</u>	<u>MAXIMUM INPUT</u>
(1)	(2)	(3)	(4)	(5)
mm		m ³ /mm	m ³ /min/W	W
200	Capacitor ac and dc	14	0.5	28
	Non-capacitor ac	14	0.45	32
250	Capacitor ac and dc	20	0.65	31
	Non-capacitor ac	20	0.60	34
300	Capacitor ac and dc	30	0.75	40
	Non-capacitor ac	30	0.65	47
400	Capacitor ac and dc	65	1.08	61
	Non-capacitor ac	65	0.90	73

10. TESTS

10.1 Categories of Tests

10.1.1 Type Tests — The tests specified below shall constitute type tests and shall be carried out on three samples of the same type and rating selected preferably at random from a regular production lot:

- a) Air delivery (10.3);
- b) Temperature-rise (10.4);
- c) Leakage current (10.5);
- d) High voltage (10.6);
- e) Insulation resistance (10.7.1);
- f) Starting (10.8);
- g) Fan speed and input (10.9);
- h) Earthing connection (10.10);
- i) Protection against electric shock (10.11);
- k) Moisture resistance (10.12);
- m) Mechanical endurance test (for regulator only) (10.13);
- n) Cord grip (10.14);
- p) Oscillating mechanism (under consideration) (10.15); and
- q) Creepage distances and clearances (10.16).

10.1.2 Acceptance Tests — The following shall constitute acceptance tests:

- a) Starting (10.8);
- b) Fan speed and input (10.9);
- c) Earthing connection (10.10);
- d) Leakage current (10.5); and
- e) High voltage (10.6).

10.1.2.1 A recommended sampling plan for acceptance tests is given in Appendix B.

10.1.3 Routine Tests:

- a) Flash test (10.6.5);
- b) Insulation resistance (10.7.2); and
- c) A simple running test to determine that the fan and the oscillating mechanism, if fitted, are in working order.

10.2 General Condition of Test

10.2.1 Test Voltage — The voltage at which the tests are conducted shall be as follows:

10.2.1.1 When a rated voltage is indicated on the name-plate, the test shall be conducted at the rated voltage. If the fan is specified for two or more distinct rated voltages with three or more supply terminals, the tests shall be carried out at all voltages.

10.2.1.2 When a voltage range is indicated on the name-plate, the test voltage shall be as given in the table below:

Sl	Test	Test Voltage
No.		

	<u>When the Voltage Range is in Excess of 10 percent of the Lowest Voltage highest value of range</u>	<u>When the Voltage Range is less than 10 percent of the Lowest Voltage</u>
i) <u>Temperature- rise</u>		
ii) <u>Starting</u>	<u>90 Percent of the lowest value of range (see 10.8)</u>	<u>Mean of the upper and lower limits</u>
iii) <u>Air delivery and service value</u>	<u>Highest and lowest values of range</u>	
iv) <u>Power factor and speed</u>	<u>Highest and lowest values of range</u>	

Formatted Table

Formatted: Font: (Default) Times New Roman, 12 pt

Formatted: Font: (Default) Times New Roman, 12 pt

Formatted: Indent: Left: 0.01 cm, Tab stops: 6.65 cm, Left + Not at 2.54 cm + 3.81 cm

Formatted: Indent: Left: 0 cm

Formatted: Font: (Default) Times New Roman, 12 pt

Formatted: Indent: Left: 0 cm

For a fan with a range of frequency, the test shall be made at the frequency which gives the most unfavourable result.

10.2.1.3 Limits of voltage variation — The variation in the test voltage shall not exceed ± 1 percent of the test voltage during air delivery tests. . While taking the current and watt readings during these tests, however, the voltage shall be maintained at the test voltage.

10.2.2 Limits of Error of Electrical Instruments — The error in the indicated value of ammeters, voltmeters and wattmeters shall not exceed 0.5 percent of full-scale value for instruments used for type tests. For routine and acceptance tests, industrial class instruments (see IS : 1248 (Pt 1)) may be used.

10.3 Air Delivery Test

10.3.1 Test Chamber — The fan shall be tested in a test chamber of length 4.50 m, width 4.50 m, and height 3.0 m. This chamber shall be reasonably free from extraneous draughts while the test is being carried out.

The test chamber shall be free from obstructions other than the stand on which the fan is kept. Any table or shelf for electrical instruments shall be on the intake side of the fan, beyond a distance of 0.90 m from the plane of the fan blades. No heating or cooling apparatus shall be used in the test room while the test is in progress.

The fan shall be mounted with the blade centre 1.20 m from the floor and with the front of the blades at least 1.20 m from the back wall and at least 1.80 m from the side walls.

10.3.2 Testing Instrument — The air movement shall be measured by means of medium or low velocity rotating vane anemometer having an internal diameter of 70 mm, suitable for the range of velocity to be measured. Revolving vane anemometers having a diameter up to 100 mm may also be used alternatively. It is recommended that the anemometer be calibrated frequently.

10.3.3 Arrangement of Apparatus

10.3.3.1 The arrangement of the apparatus (see Fig. 2) shall be such as to permit the anemometer being moved in a horizontal plane containing the axis of the fan, the movement being at right angles to the axis and extendable in both directions. The anemometer shall be supported in such a manner as to offer as little obstruction as possible to the air flow. The axis of the anemometer vane shall always be parallel to the axis of the fan blades.

The distance between the test plane and the plane of the fan blades shall be as specified below:

Size of Fan	Distance between the Test Plane And the Plane of the fan Blades
mm	mm
200	600
250	750
300	900
400	1200

10.3.4 Procedure for Test — Before taking any steps towards testing a fan against this standard, it is essential that it should have been 'run-in' for at least one hour at the highest voltage of the rated voltage range.

The measurements shall be carried out with the fan running at full speed at the test voltage with the guard in position.

10.3.4.1 Air velocity — Readings shall be commenced at a point 20 mm from the axis of the fan blades, and shall progress along the horizontal line in each direction, by increments of 40 mm wide. Readings shall be continued in each direction until the true air velocity falls below 24 m per minute.

Each reading shall consist of the time taken by an air movement of 200 m measured by the anemometer, except when such air movement takes more than two minutes; the reading shall then consist of the time taken by a movement of some convenient and readable quantity of air requiring approximately two minutes. In no case should the duration of the reading be less than one minute.

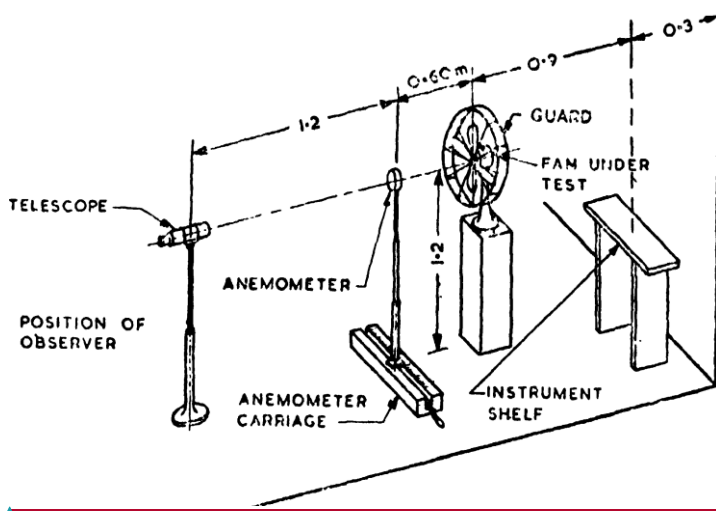

Formatted: Font: (Default) Times New Roman, 12 pt

All dimensions in millimetres.

FIG. 2 ARRANGEMENT FOR AIR DELIVERY TEST

The average air velocity over any annulus shall be the mean of the readings on either side of the axis of the fan blades at each mean radius of annulus.

The average velocity so obtained, multiplied by the area of the corresponding annulus shall be taken as the total air delivery through that annulus.

The sum of the air deliveries through all such annuli up to the limit of air velocity specified above shall be taken as the measured air delivery of the fan for the purpose of this standard.

Air conditions (temperature, relative humidity, pressure) obtained at the test chamber during tests shall be recorded with the test result.

NOTE — No correction is to be made until an agreement is available on correction factor.

10.4 Temperature-rise Test

10.4.1 Measurement of Cooling Air Temperature during Tests — The cooling air temperature shall be measured by means of several thermometers placed at different points around the fan motor at a distance of one to two metres, and protected from all heat radiations and extraneous draughts. The thermometers used for this test shall be accurate to ±0.5°C.

The value to be adopted for the temperature of the cooling air during a test shall be the mean of the readings of the thermometers taken at equal intervals of time during the last quarter of the duration of the test.

10.4.2 Measurement of Temperature-rise — The temperature-rise measurements shall be carried out by the method indicated in Table 2, immediately after the air delivery test or after the fan has been run long enough to ensure that the temperature-rise has reached a constant value.

All temperature-rises to be measured by the thermometer method [Items (iii), (iv) and (v) of Table 2] shall be taken at the hottest accessible surface of the part, as also on the parts which are likely to cause injury to any adjacent insulating material.

The method of measurement of temperature-rise by change in resistance for copper conductors is given below:

The temperature-rise t_2-t_1 may be obtained from the ratio of the resistances by the formula:

$$\frac{t_2+235}{t_1+235} = \frac{R_2}{R_1}$$

where

R_2 = resistance of the winding at temperature t_2 (°C) at the end of the test, and

R_1 = initial resistance of the winding at temperature t_1 (°C) (cold).

From the above, the hot temperature (t_2) may be expressed as:

$$t_2 = \frac{R_2}{R_1} (t_1 + 235) - 235$$

NOTE — The necessary correction to the final temperature $t_2^\circ\text{C}$ as indicated by any initial variation between $t_1^\circ\text{C}$ and the ambient temperature when hot resistance is measured may have to be made.

10.5 Leakage Current — The test shall be carried out according to 13.2 of IS : 302-1.

10.6 High Voltage Test

10.6.1 The source of supply for high voltage test shall be not less than 500 VA.

10.6.2 The high voltage test shall be applied to all new and completed fan motors and regulators in normal working conditions with all parts in place except the capacitors which should be disconnected.

10.6.3 An ac test voltage at any convenient frequency between 40 and 60 Hz of approximately sine wave-form shall be applied and maintained for one minute without showing any kind of breakdown or flashover.

The test voltage shall be applied as follows:

a) For fan motors:

- 1) Between live parts and body in the case of motors 1 500 volts intended to be earthed
- 2) Between live parts and other inaccessible metal 1 500 volts parts (that is, over the functional insulation) in the case of double insulated motors
- 3) Between the inaccessible metal parts and the body 2 500 volts (that is, over the supplementary insulation) in the case of double insulated motors
- 4) Between live parts and body (that is, over the 4 000 volts reinforced insulation) for reinforced insulated motors

b) For regulators:

- 1) Between any terminal and the body 1 500 volts
- 2) Between the terminals with the regulator in the 1 500 volts. 'OFF' position

10.6.4 At the end of one minute, the test voltage shall be removed and the insulation-resistance test conducted as in 10.7.

10.6.5 Flash Test (Routine Test) — Every fan and regulator shall withstand the voltage specified in 10.6 for one second when it is applied instantaneously.

10.7 Insulation Resistance

10.7.1 Insulation Resistance (Type Test) — When conducted as a type test for fans and regulators, this test shall follow the moisture resistance test (10.12). The insulation resistance of the fan and regulators shall be measured with dc voltage of approximately 500 V, the measurement being made 1 minute after the application of the voltage. The insulation resistance shall not be less than 2 M.

10.7.2 Insulation Resistance (Routine Test) — shall be carried out on fans and regulators immediately after conducting the flash test.

10.8 Startings — The fan shall be capable of starting up from rest with the regulator, if any, at the lowest speed step, when 90 percent of the rated voltage or 90 percent of the lowest voltage in the voltage range is applied with the oscillating mechanism, in the case of fans of oscillating and double oscillating types, in action and in the worst position and with the axis about which the fan motor swivels being at the maximum angle, for which the fan was designed as declared by the manufacturer, to the horizontal plane so that the air is directed outwards. The test shall be repeated 10 times.

10.9 Fan Speed and Input—The fan is connected to the supply at the test voltage and at the highest speed of setting with the axis of the blades perpendicular to test plane. The power factor under the above conditions shall not be less than 0.90 for capacitor type and 0.50 for non-capacitor type fans. The oscillating mechanism shall then be connected with the axis of the blades horizontal at the test voltage with the regulator in the highest speed position. The electrical input and speed shall be measured with and without the oscillating mechanism. The input shall not exceed the marked input by more than 10 percent and the speed shall not differ from the declared value by ± 10 percent.

10.10 Earthing Connection

10.10.1 A current derived from an ac source having a no-load voltage not exceeding 12 V, and equal to 1.5 times the rated current of the appliance or 25 A, whichever is greater, is passed between the earthing terminal or earthing contact and each of the accessible metal parts in term. The voltage drop between the earthing terminal of the fan and the accessible metal part is measured and the resistance is calculated from the voltage drop and the current. The resistance value shall not exceed 0.1 Ω . Care is taken that the contact resistance between the tip of the measuring probe and the metal part under test does not influence the test results.

10.10.2 This provision does not apply to rotating parts supported by metal bearings.

10.11 Protection Against Electric Shock—The test shall be conducted as per 8 of IS 302 (Part 2/Sec 80).

10.12 Moisture Resistance Test—The humidity treatment is carried out in a humidity cabinet containing air with a relative humidity of not less than 95 percent. The temperature of the air at all places where samples can be located is maintained at any convenient temperature in the range $40 \pm 5^\circ\text{C}$ for a period of 48 hours.

10.13 Mechanical Endurance Test (for Regulators only)—The regulator shall continue to function satisfactorily after being subjected to a test of 2 500 operations of the regulator switch when connected to a fan with locked rotor or an electrical load of equivalent impedance supplied at the maximum rated voltage. One operation includes a full cycle of movement from the

'OFF' position to the 'full speed' position (or to the other extreme position) and back to 'OFF'. The test shall be made approximately at the rate of 6 operations per minute.

10.14 Cord Grip Test

10.14.1 The flexible cord shall be connected to the fan with the cord grip in the normal position. The conductors shall be introduced into the terminal and screws, if any, shall be slightly tightened so that the conductors cannot easily change their position. After this it shall not be possible to push the cord further into the fan.

10.14.2 The flexible cord shall then be subjected 100 times to a pull of 10 kgf for one second. Immediately afterwards, the cord shall be subjected to a torque of 3.5 kgf/cm for a period of 1 minute. The test shall be

made with the flexible cord suitable for the fan and conforming to IS 9968 (Pt 1) or IS : 694. During the test no damage shall be caused to the flexible cord.

10.15 Oscillating Mechanism — (Under consideration).

10.16 Creepage Distances and Clearances — The test shall be conducted according to the relevant provisions of 29 of IS : 302 (Part 2/Sec 80).

NOTE — These provisions shall not be applicable to motor winding.

APPENDI X A
(Clause 7.3)

ADDITIONAL INFORMATION TO BE SUPPLIED BY THE MANUFACTURER

A-1. The following additional information in respect of a table fan shall be supplied by the manufacturer on request:

- a) Power factor;
- b) Rated speed in rev/min (with and without oscillating mechanism to be specified separately);
- c) Air delivery at test voltage;
- d) Service value at rated voltage;
- e) Number of blades
- f) Type of regulator and number of running positions;
- g) Class of insulation;
- h) Type of bearings; and
- j) Instructions for lubrication of bearings.

APPENDI X B
(Clause 10.1.2.1)
RECOMMENDED SAMPLING PLAN

B-1. SCALE OF SAMPLING

B-1.1 Lot — All fans along with associated regulator of the same type, grade, category and rating manufactured under similar conditions of production shall be grouped together to constitute a lot.

B-1.2 The number of fans to be selected from the lot shall depend upon the size of the lot and shall be in accordance with Table 4.

TABLE 4 SAMPLE SIZE AND CRITERIA FOR CONFORMITY

<u>LOT SIZE</u>	<u>STAGE</u>	<u>SAMPLE SIZE</u>	<u>CUMULATIVE SAMPLE SIZE</u>	<u>ACCEPTANC NUMBER</u>	<u>REJECTION NUMBER</u>
<u>(1)</u>	<u>(2)</u>	<u>(3)</u>	<u>(4)</u>	<u>(5)</u>	<u>(6)</u>

Up to 15	First	3	3	0	1
16 to 200	First	5	5	0	2
	Second	10	15	1	2
201 and above	First	7	7	0	2
	Second	14	21	2	3

NOTE — For lot size up to 15, decision regarding acceptance or rejection shall be taken at the first stage only.

B-1.2.1 These fans shall be selected from the lot at random. In order to ensure randomness of selection, procedures given in IS : 4905 may be followed.

B-2. NUMBER OF TESTS AND CRITERIA FOR CONFORMITY

B-2.1 The fans selected at the first stage according to col 1 and 3 of Table 3 shall be subjected to the acceptance tests specified in 10.1.2.1. A fan, failing to satisfy any of the acceptance tests, shall be considered as defective. The lot shall be considered as conforming to the requirements if the number of defectives found in the sample is less than or equal to the acceptance number (see col 5) and shall be rejected if it is greater than or equal to the rejection number (see col 6). If the number of defectives lie between the acceptance number and rejection number, the second sample of the same size shall be chosen at random and tested. If the number of defectives found in the combined samples is greater than or equal to the rejection number, the lot shall be rejected, otherwise the lot shall be accepted.

7. GENERAL AND SAFETY REQUIREMENTS

7.1 Protection Against Electric Shock — Fans and regulators shall be so constructed and enclosed that there is adequate protection against accidental contact with live parts and for class II type, with metal parts, separated from live parts by functional insulation only. This requirement is applicable for all positions in the normal use.

7.2 Electrical Insulation Under Normal Operating Conditions

7.2.1 The electrical insulation of the fans and regulators at operating temperature shall be adequate and the leakage current in normal use shall not be excessive.

7.2.1.1 When measured according to the method specified in 10.7.1 the insulation resistance shall not be less than 2 MΩ.

7.2.1.2 Leakage current (see 10.5):

a) For class I type fans and regulators the leakage current which may flow from the live parts to the accessible parts and metal foil on external insulating material connected together shall not exceed 300 μA (peak), that is 210 μA (rms).

b) For class II type fans and regulators the leakage current from live parts to the inner non-current carrying metal shall not exceed 300 μA (peak), whereas the leakage current from the live parts to the metal foil wrapping (for all insulated fans and regulators) or the external metal and metal foil wrapping connected together (for double insulated fans and regulators) shall not exceed 60 μA (peak), that is 42.5 μA (rms).

Formatted: Centered, Tab stops: 0.95 cm, Left + 5.4 cm, Left + 8.57 cm, Left + 12.06 cm, Left + 15.87 cm, Left

Formatted: Font: Not Bold

Formatted: Font: Not Bold

Formatted: Highlight

Formatted: Highlight

7.2.13 The insulation is subjected for one minute to a voltage of substantially sine wave form having a frequency of 50 Hz as given in 10.6.

7.3 Temperature rise — The fan motor and regulator shall be tested at any cooling air temperature not exceeding 40°C, but whatever may be the value of this temperature, the permissible temperature rise shall not exceed the values shown in Table 2.

IS: 555 – 202X

TABLE 2 PERMISSIBLE LIMITS OF TEMPERATURE RISE

NO	PART OF MOTOR OR REGULATOR	METHOD			MEASURE
		Class E	Class B	Class A	
(2)	Insulated windings of motors	60	75	85	Change of resistance
(3)	Insulated windings, if any, of regulator (with continuous running on any contact)	60	75	85	Change of resistance
(4)	External surfaces other than metallic handles, likely to be touched momentarily during normal usage	40	40	40	Thermometer
(5)	Metallic handles	20	20	20	Thermometer
(6)	External surface of capacitors	45	45	45	Thermometer

Formatted: Highlight

Formatted: Highlight

Formatted: Highlight

Formatted: Highlight

NOTE 1 — The thermocouples, if used, should be applied only to external surfaces which may be reached by an ordinary thermometer.

NOTE 2 — The temperature rise values given above are for fans normally made to this specification to work in cooling air temperatures not exceeding 40°C. Nevertheless, fans made to work in higher cooling air

temperatures may be regarded as complying with this specification, provided the temperature rise values are

7.4 Mechanical Endurance—The fan regulators shall be robust in construction and shall meet the requirements specified in 10.13.

7.5 Creepage Distances and Clearances—The relevant provisions of 29 of IS : 302-202X* shall apply.

NOTE—These provisions shall not be applicable to motor winding.

7.6 Finish—All the surfaces of both the fan motor with blades and regulator, if any, shall be of corrosion-resisting material or shall be suitably and durably protected against corrosion.

7.7 Insulating Materials—With the exception of resistance wires in regulators, windings of fans and regulators shall be insulated either with Class A, Class B or with Class E insulating materials which comply with the limits of temperature rise specified in 7.3 and moisture resistance test specified in 10.12. The insulating materials are detailed in IS : 1271-1958†.

7.8 Speed Regulators

7.8.1 Speed regulators shall be capable of reducing the speed of the fan by at least 30 percent of the full speed at the test voltage and frequency specified for the test, except in the case of fans of the shaded pole type, where the speed reduction shall be not less than 20 percent. Fans shall be capable of running continuously on any of the running positions of the regulator at the rated voltage or voltages (see 2.3) or within the whole rated voltage range (see 2.4), whichever is applicable.

IS 555—202X

7.8.2 The regulator for 300 mm and 400 mm size fans shall have an 'OFF' position preferably next to the lowest speed contact, and shall be provided with running positions as specified in 3.1. The speed difference at any running position shall not deviate by more than ± 50 percent from the ideal speed difference calculated on the basis of maximum and minimum speeds divided by the number of steps provided in the speed regulator.

NOTE—The following example illustrates the significance of this clause: Let the maximum speed of the fan be 1 200 rev/min and the minimum speed be 840 rev/min.

Then the ideal speed difference will be rev/min (if 3 running positions are provided). The speed difference between any two running positions should be between 270 and 90 rev/min.

7.8.3 Where a regulator is provided with a capacitor not permanently connected across the motor terminals, provision shall be made so that the capacitor is discharged when the regulator is in the 'OFF' position.

*General and safety requirements for household and similar electrical appliances (fifth revision). †Classification of insulating materials for electrical machinery and apparatus in relation to their thermal stability in service.

7.8.4 The regulator handle or knob or push buttons shall either be of insulating material or, if of metal, shall be adequately insulated electrically and thermally so that its temperature rise above ambient is limited to 20°C. All metallic parts associated with it shall be protected from accidental contact.

7.8.5 The regulator handle or knob shall be so placed that it may be safely and conveniently manipulated, and unless continuously variable, shall only rest in one of the regulating positions. The handle or knob shall be so designed that it does not become loose in use. The 'running' and 'OFF' positions of the regulator shall be distinctly and clearly marked and the indicator on the operating handle or knob shall correctly indicate the position of the regulator.

7.8.6 The regulators should have mechanical stops for the regulator moving contact to prevent accidental contact with the metallic body of the regulator in the event of forced overtravel of the knob.

7.8.7 The mechanism of the regulator shall be so designed as to ensure positive contact at each running position. In the case of inductance type regulators, it is essential that no portion of the inductive winding should remain permanently short-circuited in any of the running positions.

7.9 Interchangeability—The motor of the fan of a particular size and model and its associated regulator and set of blades shall be interchangeable such that the performance of the fan keeps within specified limits (see 8).

7.10 Silent Operation—Precautions shall be taken in the manufacture of fans and regulators to ensure an **NOTE**—The need for specifying limits of noise levels (acoustical) of the fans is recognized. However, it has not been found possible to specify these limits at present on account of:

- a) dependency of these limits on the actual location of the fans;
- b) lack of data on the acceptable noise levels for different applications; and
- e) lack of agreed definition of noise level and method of evaluating the same. The criterion of noise level may, therefore, be subject to an agreement between the manufacturer and the purchaser.

IS 555—202X

7.11 Oscillating Mechanism

- 7.11.1** The number of oscillations (that is, complete to and fro movements) per minute at full speed shall be not less than four.
- 7.11.2** Whether the angular movement of the mechanism is variable or not, an angular movement of not less than 60° shall be available (see Fig. 1).
- 7.11.3** A device shall be provided to render the oscillating mechanism inoperative when desired. The method of operating the device should preferably be indicated. Means shall be provided to ensure that, when properly.

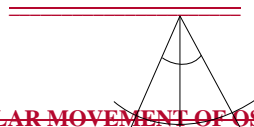

FIG. 1 ANGULAR MOVEMENT OF OSCILLATION

Installed, the fan is not stalled or overturned if the oscillating mechanism is impeded.

8. PERFORMANCE REQUIREMENT

- 8.1 The minimum air delivery and service value at test voltage and at full speed shall be as given in Table 3.
- 8.2 For compliance with requirements of this standard, the values of air delivery and service value shall not be less than those specified in Table 3. In case higher values of air delivery and service are declared by the manufacturer (see 9.3), the observed results, expressed as the percentage of the values declared by the manufacturer shall not be less than 90 percent of the declared values.

TABLE 3 MINIMUM AIR DELIVERY AND SERVICE VALUE FOR TYPE A FANS
(Class 8.1)

FAN SIZE	DELIVERY	(2)	(3)	TYPE	SERVICE VALUE	AIR
			(4)			
mm	m ³ /mm					m ³ /min/w
200	Capacitor ac and dc	14			0.5	
	Non capacitor ac	14			0.45	
250	Capacitor ac and dc	20			0.65	
	Non capacitor ac	20			0.60	
300	Capacitor ac and dc	30			0.75	
	Non capacitor ac	30			0.65	
400	Capacitor ac and dc	65			1.08	
	Non capacitor ac	65			0.90	

~~9. MARKING~~

~~9.1 Each fan shall be indelibly marked with at least the following information:~~

- ~~a) Manufacturer's name, trade name of fan (if any), and number;~~
- ~~b) Rated voltage(s) or voltage range; c) Type of fan ac or dc;~~
- ~~d) Frequency or frequency range of power supply, if of ac;~~
- ~~e) Input in watts (with oscillating mechanism at the highest speed setting of regulator);~~
- ~~f) Size of fan; and g) Country of manufacture.~~

~~NOTE 1—The trade name, voltage and the size of the fan shall be marked on the associated regulator, if supplied separately.~~

~~NOTE 2—Item (a) and (g) (manufacturer's name, etc. and country of manufacture) may not be marked if specifically desired by the purchaser.~~

~~9.2 In the case of a fan and a regulator provided with an earthing terminal or contact, it shall be indelibly marked with the symbol '—'.~~

~~9.3 For additional information that the manufacturer may be requested to supply (see Appendix A).~~

~~9.4 Table type fans may also be marked with the ISI Certification Mark.~~

~~NOTE—The use of the ISI Certification Mark is governed by the provisions of the Indian Standards Institution (Certification Marks) Act and the Rules and Regulations made thereunder. The ISI Mark on products covered by an Indian Standard conveys the assurance that they have been produced to comply with the requirements of that standard under a well defined system of inspection, testing and quality control which is devised and supervised by ISI and operated by the producer. ISI marked products are also continuously checked by ISI for conformity to that standard as a further safeguard. Details of conditions under which a licence for the use of the ISI Certification Mark may be granted to manufacturers or processors, may be obtained from the Indian Standards Institution.~~

10. TESTS

10.1 Categories of Tests

10.1.1 Type Tests—The tests specified below shall constitute type tests and shall be carried out on three samples of the same type and rating selected preferably at random from a regular production lot:

- a) Air delivery (10.3);
- b) Temperature rise (10.4);
- c) Leakage current (10.5);
- d) High voltage (10.6);
- e) Insulation resistance (10.7.1);
- f) Starting (10.8);
- g) Fan speed and input (10.9);
- h) Earthing connection (10.10);
- j) Protection against electric shock (10.11);
- k) Moisture resistance (10.12);
- m) Mechanical endurance test (for regulator only) (10.13);
- n) Cord grip (10.14);
- p) Oscillating mechanism (under consideration) (10.15); and
- q) Creepage distances and clearances (10.16).

10.1.2 Acceptance Tests—The following shall constitute acceptance tests:

- a) Starting (10.8);
- b) Fan speed and input (10.9);
- c) Earthing connection (10.10);
- d) Leakage current (10.5); and
- e) High voltage (10.6).

10.1.2.1 A recommended sampling plan for acceptance tests is given in Appendix B.

10.1.3 Routine Tests:

- a) Flash test (10.6.5);
- b) Insulation resistance (10.7.2); and
- e) A simple running test to determine that the fan and the oscillating mechanism, if fitted, are in working order.

10.2 General Condition of Test

10.2.1 Test Voltage—The voltage at which the tests are conducted shall be as follows:

10.2.1.1 When a rated voltage is indicated on the name plate, the test shall be conducted at the rated voltage. If the fan is specified for two or more distinct rated voltages with three or more supply terminals, the tests shall be carried out at all voltages.

10.2.1.2 When a voltage range is indicated on the name plate, the test voltage shall be as given in the table below:

Sl No.	Test	Test Voltage
	When the Voltage Range is less than 10 percent of Lowest Voltage	When the Voltage Range is Excess of 10 percent of Lowest Voltage
	Temperature-rise	highest value of range
Starting	Mean of the upper and lower limits	90 Percent of the lowest value of range (see 10.8)
Air delivery and Power factor and	Highest and lowest service values of range	Highest and lowest speed values of range

For a fan with a range of frequency, the test shall be made at the frequency which gives the most unfavourable result.

10.2.1.3 Limits of voltage variation — The variation in the test voltage shall not exceed ± 1 percent of the test voltage during air delivery tests. While taking the current and watt readings during these tests, however, the voltage shall be maintained at the test voltage.

10.2.2 Limits of Error of Electrical Instruments — The error in the indicated value of ammeters, voltmeters and wattmeters shall not exceed 0.5 percent of full scale value for instruments used for type tests. For routine and acceptance tests, industrial class instruments (see IS : 1248-1968)* may be used.

10.3 Air Delivery Test

10.3.1 Test Chamber — The fan shall be tested in a test chamber of length 4.50 m, width 4.50 m, and height 3.0 m. This chamber shall be reasonably free from extraneous draughts while the test is being carried out.

— The test chamber shall be free from obstructions other than the stand on which the fan is kept. Any table or shelf for electrical instruments shall be on the intake side of the fan, beyond a distance of 0.90 m from the plane of the fan blades. No heating or cooling apparatus shall be used in the test room while the test is in progress.

— The fan shall be mounted with the blade centre 1.20 m from the floor and with the front of the blades at least 1.20 m from the back wall and at least 1.80 m from the side walls.

— *Specification for direct acting electrical indicating instrument (first revision).

IS 555—202X

10.3.2 Testing Instrument—The air movement shall be measured by means of medium or low velocity rotating vane anemometer having an internal diameter of 70 mm, suitable for the range of velocity to be measured. Revolving vane anemometers having a diameter up to 100 mm may also be used alternatively. It is recommended that the anemometer be calibrated frequently.

10.3.3 Arrangement of Apparatus

—10.3.3.1 The arrangement of the apparatus (see Fig. 2) shall be such as to permit the anemometer being moved in a horizontal plane containing the axis of the fan, the movement being at right angles to the axis and extendable in both directions. The anemometer shall be supported in such a manner as to offer as little obstruction as possible to the air flow. The axis of the anemometer vane shall always be parallel to the axis of the fan blades.

—The distance between the test plane and the plane of the fan blades shall be as specified below:

Size of Fan	Distance between the Test Plane And the Plane of the fan Blades
mm	mm
200	600
250	750
300	900
400	1200

10.3.4 Procedure for Test—Before taking any steps towards testing a fan against this standard, it is essential that it should have been 'run in' for at least one hour at the highest voltage of the rated voltage range.

The measurements shall be carried out with the fan running at full speed at the test voltage with the guard in position.

10.3.4.1 Air velocity—Readings shall be commenced at a point 20 mm from the axis of the fan blades, and shall progress along the horizontal line in each direction, by increments of 40 mm wide. Readings shall be continued in each direction until the true air velocity falls below 24 m per minute.

—Each reading shall consist of the time taken by an air movement of 200 m measured by the anemometer, except when such air movement takes more than two minutes; the reading shall then consist of the time taken by a movement of some convenient and readable quantity of air requiring approximately two minutes. In no case should the duration of the reading be less than one minute.

~~IS 555—202X~~

~~All dimensions in millimetres.
FIG. 2 ARRANGEMENT FOR AIR DELIVERY TEST~~

~~— The average air velocity over any annulus shall be the mean of the readings on either side of the axis of the fan blades at each mean radius of annulus.~~

~~— The average velocity so obtained, multiplied by the area of the corresponding annulus shall be taken as the total air delivery through that annulus.~~

~~— The sum of the air deliveries through all such annuli up to the limit of air velocity specified above shall be taken as the measured air delivery of the fan for the purpose of this standard.~~

~~— Air conditions (temperature, relative humidity, pressure) obtained at the test chamber during tests shall be recorded with the test result.~~

~~NOTE — No correction is to be made until an agreement is available on correction factor.~~

~~10.4 Temperature-rise Test~~

~~10.4.1 Measurement of Cooling Air Temperature during Tests — The cooling air temperature shall be measured by means of several thermometers placed at different points around the fan motor at a distance of one to two metres, and protected from all heat radiations and extraneous draughts. The thermometers used for this test shall be accurate to $\pm 0.5^{\circ}\text{C}$.~~

IS 555—202X

The value to be adopted for the temperature of the cooling air during a test shall be the mean of the readings of the thermometers taken at equal intervals of time during the last quarter of the duration of the test.

10.4.2 Measurement of Temperature rise—The temperature rise measurements shall be carried out by the method indicated in Table 2, immediately after the air delivery test or after the fan has been run long enough to ensure that the temperature rise has reached a constant value.

—All temperature rises to be measured by the thermometer method [Items (iii), (iv) and (v) of Table 2] shall be taken at the hottest accessible surface of the part, as also on the parts which are likely to cause injury to any adjacent insulating material.

—The method of measurement of temperature rise by change in resistance for copper conductors is given below:

—The temperature rise $t_2 - t_1$ may be obtained from the ratio of the resistances by the formula:

$$\frac{t_2 + 235}{t_1 + 235} = \frac{R_2}{R_1}$$

—where

R_2 = resistance of the winding at temperature t_2 (°C) at the end of the test, and

R_1 = initial resistance of the winding at temperature t_1 (°C) (cold).

—From the above, the hot temperature (t_2) may be expressed as:

$$t_2 = \frac{R_2}{R_1} (t_1 + 235) - 235$$

—NOTE—The necessary correction to the final temperature t_2 °C as indicated by any initial variation between t_1 °C and the ambient temperature when hot resistance is measured may have to be made.

10.5 Leakage Current—The test shall be carried out according to 13.2 of IS : 302-202X*.

10.6 High Voltage Test

10.6.1 The source of supply for high voltage test shall be not less than 500 VA.

10.6.2 The high voltage test shall be applied to all new and completed fan motors and regulators in normal working conditions with all parts in place except the capacitors which should be disconnected.

—*General and safety requirements for household and similar electrical appliances (fifth revision).

IS 555—202X

10.6.3 An ac test voltage at any convenient frequency between 40 and 60 Hz of approximately sine wave-form shall be applied and maintained for one minute without showing any kind of breakdown or flashover.

The test voltage shall be applied as follows:

a) For fan motors:

1) Between live parts and body in the case of motors 1 500 volts intended to be earthed

2) Between live parts and other inaccessible metal 1 500 volts parts (that is, over the functional insulation) in the case of double insulated motors

3) Between the inaccessible metal parts and the body 2 500 volts (that is, over the supplementary insulation) in the case of double insulated motors

4) Between live parts and body (that is, over the 4 000 volts reinforced insulation) for reinforced insulated motors

b) For regulators:

1) Between any terminal and the body 1 500 volts

2) Between the terminals with the regulator in the 1 500 volts, 'OFF' position

10.6.4 At the end of one minute, the test voltage shall be removed and the insulation resistance test conducted as in 10.7.

10.6.5 Flash Test (Routine Test) — Every fan and regulator shall withstand the voltage specified in 10.6 for one second when it is applied instantaneously.

10.7 Insulation Resistance

10.7.1 Insulation Resistance (Type Test) — When conducted as a type test for fans and regulators, this test shall follow the moisture resistance test (10.12). The insulation resistance of the fan and regulators shall be measured with dc voltage of approximately 500 V, the measurement being made 1 minute after the application of the voltage. The insulation resistance shall not be less than 2 M.

10.7.2 Insulation Resistance (Routine Test) — shall be carried out on fans and regulators immediately after conducting the flash test.

10.8 Startings — The fan shall be capable of starting up from rest with the regulator, if any, at the lowest speed step, when 90 percent of the rated voltage or 90 percent of the lowest voltage in the voltage range is applied with the oscillating mechanism, in the case of fans of oscillating and double oscillating types, in action and in the worst position and with the axis about which the fan motor swivels being at the maximum angle, for which the fan was designed as declared by the manufacturer, to the horizontal plane so that the air is directed outwards. The test shall be repeated 10 times.

10.9 Fan Speed and Input — The fan is connected to the supply at the test voltage and at the highest speed of setting with the axis of the blades perpendicular to test plane. The power factor under the above conditions shall not be less than 0.90 for capacitor type and 0.50 for non capacitor type fans. The oscillating mechanism shall then be connected with the axis of the blades horizontal at the test voltage with the

regulator in the highest speed position. The electrical input and speed shall be measured with and without the oscillating mechanism. The input shall not exceed the marked input by more than 10 percent and the speed shall not differ from the declared value by ± 10 percent.

IS 555—202X

10.10 Earthing Connection

10.10.1 A current derived from an ac source having a no-load voltage not exceeding 12 V, and equal to 1.5 times the rated current of the appliance or 25 A, whichever is greater, is passed between the earthing terminal or earthing contact and each of the accessible metal parts in turn. The voltage drop between the earthing terminal of the fan and the accessible metal part is measured and the resistance is calculated from the voltage drop and the current. The resistance value shall not exceed 0.1 Ω . Care is taken that the contact resistance between the tip of the measuring probe and the metal part under test does not influence the test results.

10.10.2 This provision does not apply to rotating parts supported by metal bearings.

10.11 Protection Against Electric Shock—The test shall be conducted as per 40 of IS : 302-202X*.

10.12 Moisture Resistance Test—The humidity treatment is carried out in a humidity cabinet containing air with a relative humidity of not less than 95 percent. The temperature of the air at all places where samples can be located is maintained at any convenient temperature in the range $40 \pm 5^\circ\text{C}$ for a period of 48 hours.

10.13 Mechanical Endurance Test (for Regulators only)—The regulator shall continue to function satisfactorily after being subjected to a test of 2 500 operations of the regulator switch when connected to a fan with locked rotor or an electrical load of equivalent impedance supplied at the maximum rated voltage. One operation includes a full cycle of movement from the

——* General and safety requirements for household and similar electrical appliances (fifth revision)

'OFF' position to the 'full speed' position (or to the other extreme position) and back to 'OFF'. The test shall be made approximately at the rate of 6 operations per minute.

10.14 Cord Grip Test

10.14.1 The flexible cord shall be connected to the fan with the cord grip in the normal position. The conductors shall be introduced into the terminal and screws, if any, shall be slightly tightened so that the conductors cannot easily change their position. After this it shall not be possible to push the cord further into the fan.

10.14.2 The flexible cord shall then be subjected 100 times to a pull of 10 kgf for one second. Immediately afterwards, the cord shall be subjected to a torque of 3.5 kgf/cm for a period of 1 minute. The test shall be made with the flexible cord suitable for the fan and conforming to IS : 434 (Part I) 1964* or IS : 694-1977†. During the test no damage shall be caused to the flexible cord.

10.15 Oscillating Mechanism——(Under consideration).

10.16 Creepage Distances and Clearances——The test shall be conducted according to the relevant provisions of 29 of IS : 302-202X‡.

~~NOTE~~ These provisions shall not be applicable to motor winding.

~~IS 555—202X~~

~~APPENDIX A
(Clause 9.3)~~

~~ADDITIONAL INFORMATION TO BE SUPPLIED BY THE MANUFACTURER~~

~~A.1. The following additional information in respect of a table fan shall be supplied by the manufacturer on request:~~

- ~~a) Power factor;~~
- ~~b) Rated speed in rev/min (with and without oscillating mechanism to be specified separately);~~
- ~~c) Air delivery at test voltage;~~
- ~~d) Service value at rated voltage;~~

~~* Specification for rubber-insulated cables: Part I With copper conductors (revised).~~

~~† Specification for PVC insulated cables for working voltages up to and including 1 100 V (second revision). ‡ General and safety requirements for household and similar electrical appliances (fifth revision).~~

- ~~e) Number of blades~~
- ~~f) Type of regulator and number of running positions;~~
- ~~g) Class of insulation;~~
- ~~h) Type of bearings; and~~
- ~~j) Instructions for lubrication of bearings.~~

~~APPENDIX B~~

~~(Clause 10.1.2.1)~~

~~RECOMMENDED SAMPLING PLAN~~

~~B.1. SCALE OF SAMPLING~~

~~B.1.1 Lot~~ All fans along with associated regulator of the same type, grade, category and rating manufactured under similar conditions of production shall be grouped together to constitute a lot.

~~B.1.2~~ The number of fans to be selected from the lot shall depend upon the size of the lot and shall be in accordance with Table 4.

~~TABLE 4 SAMPLE SIZE AND CRITERIA FOR CONFORMITY~~

LOT SIZE	STAGE	SAMPLE	CUMULATIVE	ACCEPTANC
		REJECTION		
	SIZE	SAMPLE SIZE	NUMBER	NUMBER
(2)	(3)	(4)	(5)	(6)
Up to 15	First	3	3	0-1
16 to 200	First	5	5	0-2
	Second	10	15	1-2

201 and above	First	7	7	0	2
	Second	14	21	2	3

NOTE For lot size up to 15, decision regarding acceptance or rejection shall be taken at the first stage only.

~~IS 555-202X~~

~~B-1.2.1~~ These fans shall be selected from the lot at random. In order to ensure randomness of selection, procedures given in IS : 4905-1968* may be followed.

~~*Method for random sampling.~~

~~B-2. NUMBER OF TESTS AND CRITERIA FOR CONFORMITY~~

~~B-2.1~~ The fans selected at the first stage according to col 1 and 3 of Table 3 shall be subjected to the acceptance tests specified in 10.1.2.1. A fan, failing to satisfy any of the acceptance tests, shall be considered as defective. The lot shall be considered as conforming to the requirements if the number of defectives found in the sample is less than or equal to the acceptance number (see col 5) and shall be rejected if it is greater than or equal to the rejection number (see col 6). If the number of defectives lie between the acceptance number and rejection number, the second sample of the same size shall be chosen at random and tested. If the number of defectives found in the combined samples is greater than or equal to the rejection number, the lot shall be rejected, otherwise the lot shall be accepted.

AMENDMENT NO. 1 — NOVEMBER 1987
TO
IS: 555 — 202X SPECIFICATION FOR ELECTRIC
TABLE TYPE FANS AND REGULATORS
(Third Revision)

— (Page 14, clause 8.2) — Add the following at the end of the clause:
‘The actual input when measured shall not exceed the declared value by more than 10 percent subject to the condition that the observed value shall in no case exceed the specified value given in Table 3.’
— (Page 14, Table 3) — Substitute the following for the existing table:

TABLE 3 MINIMUM AIR DELIVERY AND SERVICE VALUE FOR TYPE A FANS
(Class 8.1)

FAN SIZE (2)	TYPE (3)		AIR DELIVERY MAXIMUM INPUT (4)		SERVICE (5)
	VALUE mm	m ³ /mm m ³ /min/W			
200	Capacitor ac and dc	14	0.5	28	
	Non capacitor ac	14	0.45	32	
250	Capacitor ac and dc	20	0.65	31	
	Non capacitor ac	20	0.60	34	
300	Capacitor ac and dc	30	0.75	40	
	Non capacitor ac	30	0.65	47	
400	Capacitor ac and dc	65	1.08	61	
	Non capacitor ac	65	0.90	73	

(ETDC-5)