

AMENDMENT NO. 2 JANUARY 2023

TO

IS 1528 (Part 1) : 2010 METHODS OF SAMPLING AND PHYSICAL TESTS FOR
REFRACTORY MATERIALS

PART 1 DETERMINATION OF PYROMETRIC CONE EQUIVALENT (PCE) OR
SOFTENING POINT

(*Fourth Revision*)

[Page 2, Clause 4.4.1 (see also Amendment No. 1)] — Substitute the following for the existing:

4.4.1 Moulding

Mix thoroughly the sample prepared under 4.3 and after adding sufficient alkali free dextrin or glue and water, form into test cones in a metal mold, preferably of brass, in the shape of tetrahedron measuring 8 mm on the sides of the base, and 28 mm high (see Fig. 1A) or form it in a metal mould into test cones in the shape of a truncated trigonal pyramid with its base at a small angle to the trigonal axis, and in accordance with dimensions given in Fig. 1B. The conversion of dimensions marked in Fig. 1B, from inch to millimeters shall be as given below.

SI Equivalents

<i>Dimensions in Inches</i>	<i>Dimensions in millimeters</i>
0.075	1.90
0.272	6.91
0.281	7.14
1.081	27.46
1.125	28.58

Price Group 4

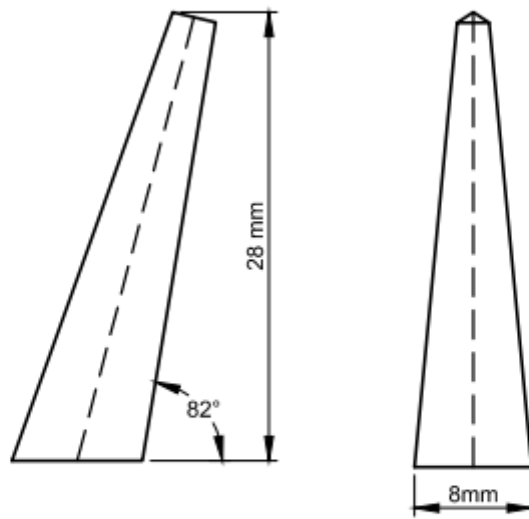

ALL DIMENSIONS IN MILLIMETERS

FIG. 1A STANDARD PYROMETRIC CONE (TETRAHEDRON)

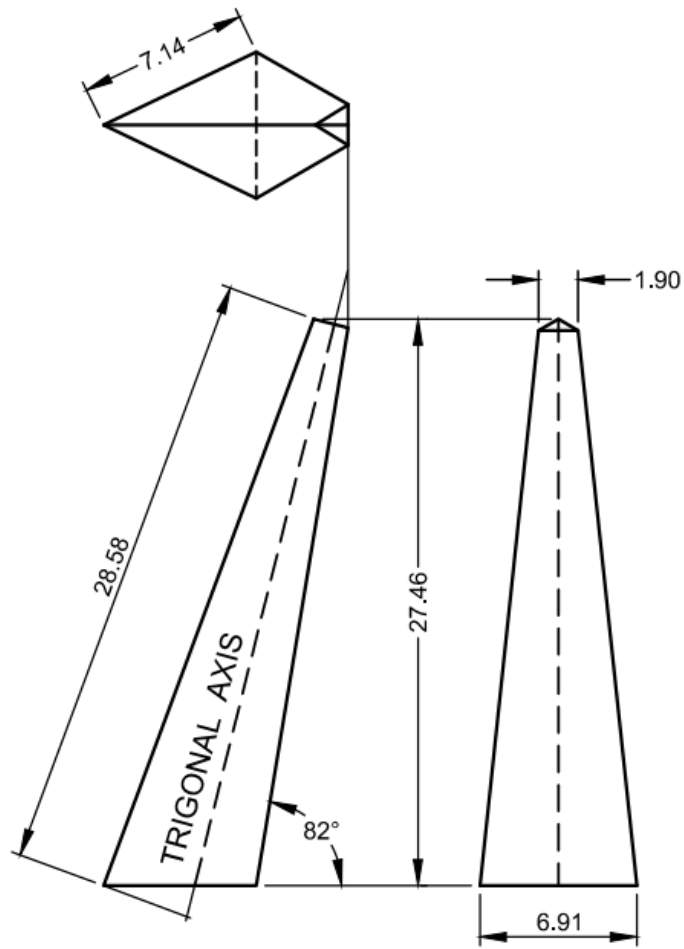

ALL DIMENSIONS IN MILLIMETERS

FIG. 1B STANDARD PYROMETRIC CONE (TRUNCATED TRIGONAL PYRAMID)

[Page 3, Table 1 (see also Amendment No. 1)] — Substitute the following for the existing Table:

Table 1 Summary of Reference Temperatures and Cone Designations of ISO, Segar, Orton and H.P.C Pyrometric Reference Cones
(Clause 4.5.1 and 4.8)

SI No.	Reference Temperature (°C)	Segar	H.P.C	Reference Temperature (°C)	ISO	Segar	Orton	H.P.C	Reference Temperature (°C)	ISO	Segar	Orton	H.P.C
(1)	(2)	(3)	(4)	(5)	(6)	(7)	(8)	(9)	(10)	(11)	(12)	(13)	(14)
i)	605	022	022	1 315	—	9	—	11	1 665	—	—	30	30
ii)	650	021	021	1 330	—	10	—	—	1 680	168	30	31	—
iii)	675	020	020	1 340	—	—	12	—	1 690	—	—	—	31
iv)	695	019	019	1 350	—	11	13	12	—	—	—	—	—
v)	715	018	018	—	—	—	—	—	170	170	31	31½	—
vi)	735	017	017	1 375	—	12	—	13	1710	—	32	—	32
vii)	760	016	016	1 395	—	13	14	—	—	—	—	—	—
viii)	785	015a	015a	—	—	—	—	—	1 720	172	32½	32½	—
ix)	815	014a	014a	1 410	—	14	—	14	—	—	—	—	—
x)	835	—	013a	—	—	—	—	—	—	—	—	—	—

Table 1 (Continued)

SI No.	Temperature (°C)	Segar	H.P.C	Temperature (°C)	ISO	Segar	Orton	H.P.C	Temperature (°C)	ISO	Segar	Orton	H.P.C
(1)	(2)	(3)	(4)	(5)	(6)	(7)	(8)	(9)	(10)	(11)	(12)	(13)	(14)
xi)	845	013a	–	1 430	–	–	15	15	1 730	–	33	–	33
xii)	855	–	012a	–	–	–	–	–	–	–	–	–	–
xiii)	880	–	011a	–	–	–	–	–	–	–	–	–	–
xiv)	890	012a	–	1 440	–	15	–	–	1 740	174	33½	33	–
xv)	–	–	–	1 460	–	–	–	16	–	–	–	–	–
xvi)	900	011a	010a	1 470	–	16	–	–	–	–	–	–	–
xvii)	–	–	–	1 480	–	–	–	17	1 750	–	–	–	34
xviii)	925	010a	09a	1 490	–	–	16	–	1 760	176	34	34	–
xix)	940	09a	08a	1 500	150	17	–	18	–	–	–	–	–
xx)	–	–	–	–	–	–	–	–	1 770	–	–	–	35
xxi)	965	08a	07a	1 510	–	–	17	–	1 780	178	35	–	–
xxii)	975	07a	06a	1 520	152	18	18	19	1 785	–	–	35	36
xxiii)	–	–	–	–	–	–	–	–	1 800	180	36	36	–
xxiv)	995	06a	05a	1 530	–	–	–	20	–	–	–	–	–
xxv)	1 010	05a	–	1 540	154	19	19	–	–	–	–	–	–

Table 1 (Continued)

Sl No.	Temperature (°C)	Segar	H.P.C	Temperature (°C)	ISO	Segar	Orton	H.P.C	Temperature (°C)	ISO	Segar	Orton	H.P.C
(1)	(2)	(3)	(4)	(5)	(6)	(7)	(8)	(9)	(10)	(11)	(12)	(13)	(14)
xxvi)	1 020	–	04a	–	–	–	–	–	–	–	–	–	–
xxvii)	1 040	–	03a	–	–	–	–	–	–	–	–	–	–
xxviii)	1 055	04a	02a	–	–	–	–	–	1 820	–	–	37	37
xxix)	1 070	03a	–	1 560	156	20	20	–	1 830	–	37	–	–
xxx)	1 080	–	01a	–	–	–	–	–	–	–	–	–	–
xxxi)	1 100	02a	1a	–	–	–	–	–	1 835	–	–	38	–
xxxii)	–	–	–	–	–	–	–	–	1 850	–	–	–	38
xxxiii)	1 125	01a	2a	1 580	158	26	–	26	1 860	–	38	39	–
xxxiv)	1 145	1a	3a	1 600	160	27	–	–	–	–	–	–	–
xxxv)	1 165	2a	4a	1 605	–	–	23	27	1 880	–	39	40	39
xxxvi)	1 185	3a	5a	1 620	162	27½	26	–	–	–	–	–	–
xxxvii)	1 200	–	6a	–	–	–	–	–	–	–	–	–	–
xxxviii)	1 220	4a	–	–	–	–	–	–	1 900	–	40	–	–

Table 1 (Concluded)

SI No.	Reference Temperature (°C)	Segar	H.P.C	Reference Temperature (°C)	ISO	Segar	Orton	H.P.C	Reference Temperature (°C)	ISO	Segar	Orton	H.P.C
(1)	(2)	(3)	(4)	(5)	(6)	(7)	(8)	(9)	(10)	(11)	(12)	(13)	(14)
xxxix)	—	—	—	1 630	—	—	—	28	1 920	—	—	—	40
xl)	1 230	5a	7	1 640	164	28	27	—	1 940	—	41	—	—
xli)	1 250	—	8	—	—	—	—	—	1 960	—	—	—	41
xlii)	1 260	6a	—	1 646	—	—	28	29	1 970	—	—	41	—
xliii)	1 270	7	—	—	—	—	—	—	1 980	—	42	—	—
xliv)	1 280	—	9	—	—	—	—	—	2 000	—	—	—	42
xlv)	1 295	8	10	1 660	166	29	29	—	2 015	—	—	42	—

NOTE — Any standard test cone is acceptable.

(MTD 15)

Publication Unit, BIS, New Delhi, India