



भारतीय मानक ब्यूरो

(उपभोक्ता मामले, खाद्य एवं सार्वजनिक वितरण मंत्रालय, भारत सरकार)

BUREAU OF INDIAN STANDARDS

(Ministry of Consumer Affairs, Food & Public Distribution, Govt. of India)

मानक भवन, 9, बहादुर शाह ज़फ़र मार्ग, नई दिल्ली - 110002

Manak Bhawan, 9, Bahadur Shah Zafar Marg, New Delhi - 110002

Mob.: 7071963270, Phones: 011-23608594, Extn: 8594

Website: [www.bis.org.in](http://www.bis.org.in), [www.bis.gov.in](http://www.bis.gov.in)

## व्यापक परिचालन मसौदा

हमारा संदर्भ: सीईडी 46 /टी-14

08 मार्च 2025

तकनीकी समिति: भारत की राष्ट्रीय भवन निर्माण विषय समिति, सीईडी 46

प्राप्तकर्ता :

1. सिविल अभियांत्रिकी विभाग परिषद, सीईडीसी के सभी सदस्य
2. राष्ट्रीय भवन निर्माण संहिता विषय समिति, सीईडी 46 के सभी सदस्य
3. सीईडी 46 की पैनल और अन्य कार्यदल के सभी सदस्य
4. रुचि रखने वाले अन्य निकाय।

महोदय/महोदया,

निम्नलिखित मानक का मसौदा संलग्न है:

प्रलेख संख्या	शीर्षक
सीईडी 46 (26704) WC	भारत की राष्ट्रीय भवन निर्माण संहिता भाग 8 भवन निर्माण सेवाएँ अनुभाग 1 प्रकाश तथा प्राकृतिक संवातन [SP7 (भाग 8, अनुभाग 1) का चौथा पुनरीक्षण] (आई सी एस नंबर: 01.120: 91.040.01)

कृपया इस मसौदे का अवलोकन करें और अपनी समितियाँ यह बताते हुए भेजे कि यह मसौदा प्रकाशित हो तो इस पर अमल करने में आपको व्यवसाय अथवा कारोबार में क्या कठिनाइयाँ आ सकती हैं।

समितियाँ भेजने की अंतिम तिथि: **07 अप्रैल 2025**

सम्मति यदि कोई हो तो कृपया अधोहस्ताक्षरी को ई-मेल द्वारा [ced46@bis.gov.in](mailto:ced46@bis.gov.in) पर या उपरलिखित पते पर, संलग्न फॉर्मेट में भेजें। समितियाँ बीआईएस ई-गवर्नेंस पोर्टल, [www.manakonline.in](http://www.manakonline.in) के माध्यम से ऑनलाइन भी भेजी जा सकती हैं।

यदि कोई सम्मति प्राप्त नहीं होती है अथवा सम्मति में केवल भाषा संबंधी त्रुटि हुई तो उपरोक्त प्रलेख को यथावत अंतिम रूप दे दिया जाएगा। यदि सम्मति तकनीकी प्रकृति की हुई तो विषय समिति के अध्यक्ष के परामर्श से अथवा उनकी इच्छा पर आगे की कार्यवाही के लिए विषय समिति को भेजे जाने के बाद प्रलेख को अंतिम रूप दे दिया जाएगा।

यह प्रलेख भारतीय मानक ब्यूरो की वेबसाइट [www.bis.gov.in](http://www.bis.gov.in) पर भी उपलब्ध है।  
धन्यवाद।

भवदीय

ह/-

(द्वैपायन भद्र)

वैज्ञानिक 'ई' एवं प्रमुख (सिविल अभियांत्रिकी विभाग)

संलग्न: उपरलिखित



भारतीय मानक ब्यूरो

(उपभोक्ता मामले, खाद्य एवं सार्वजनिक वितरण मंत्रालय, भारत सरकार)

BUREAU OF INDIAN STANDARDS

(Ministry of Consumer Affairs, Food & Public Distribution, Govt. of India)

मानक भवन, 9, बहादुर शाह ज़फर मार्ग, नई दिल्ली - 110002

Manak Bhawan, 9, Bahadur Shah Zafar Marg, New Delhi - 110002

Mob.: 7071963270, Phones: 011-23608594, Extn: 8594

Website: [www.bis.org.in](http://www.bis.org.in), [www.bis.gov.in](http://www.bis.gov.in)

## WIDE CIRCULATION DRAFT

Our Reference: CED 46/T-14

08 March 2025

### National Building Code of India Sectional Committee, CED 46

#### ADDRESSED TO:

1. All Members of Civil Engineering Division Council, CEDC
2. All Members of the National Building Code Sectional Committee, CED 46
3. All Members of Panels and Working Groups under CED 46
4. All others interested

Dear Sir/Madam,

Please find enclosed the following draft:

Doc No.	Title
CED 46 (26704) WC	<b>National Building Code of India Part 8 Building Services Section 1 Lighting and Natural Ventilation</b> [Fourth Revision of SP 7 (Part 8 Section 1)] (ICS No. 01.120: 91.040.01)

Kindly examine the attached draft and forward your views stating any difficulties which you are likely to experience in your business or profession, if this is finally adopted as National Standard.

**Last Date for comments: 07 April 2025**

Comments if any, may please be made in the enclosed format and emailed at [ced46@bis.gov.in](mailto:ced46@bis.gov.in) or sent at the above address. Additionally, comments may be sent online through the BIS e-governance portal, [www.manakonline.in](http://www.manakonline.in).

In case no comments are received or comments received are of editorial nature, kindly permit us to presume your approval for the above document as finalized. However, in case comments, technical in nature are received, then it may be finalized either in consultation with the Chairman, Sectional Committee or referred to the Sectional Committee for further necessary action if so desired by the Chairman, Sectional Committee.

The document is also hosted on BIS website [www.bis.gov.in](http://www.bis.gov.in).

Thanking you,

Yours faithfully,

Sd/-

(Dwaipayan Bhadra)  
Scientist 'E' / Director & Head  
(Civil Engineering Department)

Encl: As above



**BUREAU OF INDIAN STANDARDS**

**DRAFT FOR COMMENTS ONLY**

*(Not to be reproduced without the permission of BIS or used as a Standard)*

*Draft Indian Standard*

**National Building Code of India**

**Part 8 Building Services**

**Section 1 Lighting and Natural Ventilation**

[Fourth Revision of SP 7 (Part 8 Section 1)]

(ICS No. 01.120: 91.040.01)

---

**Technical Committee**

**Last Date for Comments:**

**National Building Code, CED 46**

**07 April 2025**

---

C O N T E N T S

FOREWORD

1 SCOPE

2 TERMINOLOGY

3 **SITE PLANNING AND BUILDING PLACEMENT**

4 LIGHTING

5 VENTILATION

ANNEX A METHOD OF CALCULATING SOLAR LOAD ON VERTICAL SURFACES OF DIFFERENT ORIENTATION

ANNEX B SKY COMPONENT TABLES

LIST OF STANDARDS

National Building Code Sectional Committee, CED 46

## FOREWORD

Thermal Comfort Conditions for the building occupants and Illumination levels for different tasks are recommended to be achieved either by daylighting or artificial lighting or a combination of both. This Section, read together with Part 8 'Building Services', Section 2 'Electrical and Allied Installations' of the Code, adequately covers the thermal comfort conditions for naturally ventilated buildings. Mixed mode operation buildings and illumination levels required and methods of achieving the same.

Ventilation requirements to maintain air quality and control body odours, and pollutants in terms of air changes per hour and to ensure thermal comfort and heat balance of body are laid for different occupancies and the methods of achieving the same by naturally or when building is operated in mixed mode operations means are covered in this Section. The provisions on mechanical ventilation are covered in Part 8 'Building Services', Section 3 'Air conditioning, Heating and Mechanical Ventilation' of the Code.

Climatic factors which normally help in deciding the orientation of the buildings to get desirable benefits of lighting and natural ventilation inside the buildings are also covered in this Section.

This Section was first published in 1970 and subsequently revised in 1983, 2005 and 2016. The first revision of the Section was brought out in 1983. In the second revision of 2005, some provisions were updated based on the information given in the SP 41:1987 'Handbook on functional requirements of buildings (other than industrial buildings)'; other major changes in the last revision included rationalization of definitions and inclusion of definitions for some more terms; inclusion of climatic classification map of India based on a new criteria; updating of data on total solar radiations incident on various surfaces of buildings for summer and winter seasons; inclusion of design guidelines for natural ventilation; reference to Part 8 'Building Services', Section 3 'Air Conditioning, Heating and Mechanical Ventilation' of the Code for guidelines on mechanical ventilation, was made, where these provisions were covered exhaustively; inclusion of rationalized method for estimation of desired capacity of ceiling fans and their optimum height above the floor for rooms of different sizes; incorporation of design sky illuminance values for different climatic zones of India, etc. Energy efficiency was another important aspect which was taken care of in the last revision of the Code. Accordingly, the relevant requirements for energy efficient system for lighting and natural ventilation were duly included in the concerned provisions under the Section.

In third revision of 2016, the changes that were incorporated include; elaboration of the calculation for solar load, and inclusion of 'Method of calculating solar load on vertical surfaces in different orientation' in Annex A; inclusion of provisions on sky component calculation procedure along with examples in Annex B; inclusion of reference to SP 41:1987 for obtaining coefficient utilization for determination of luminous flux; updation of provisions relating to efficient artificial light source and luminaires were updated; inclusion of modern lighting techniques such as LED and induction light in comparison with their energy consumption; updation of provisions relating to photocontrols for artificial lights were updated;

inclusion of definitions and enabling provision for lighting shelves and light pipes; elaboration of the provisions related to thermal comfort clause including therein indices such as effective temperature, adaptive thermal comfort along with elaborations on tropical summer index; elaboration of design guidelines for natural ventilation with illustrations; elaboration of provisions related to determination of rate of ventilation particularly on combined effect of wind and thermal actions; and inclusion of provision on colour rendering in line with that in SP 72 : 2010 'National Lighting Code 2010'.

As a result of experience gained since the implementation of the 2016 version of the Code and feedback received as well as revisions of Indian Standards on which this Section was based, a need was felt to revise this Section. The significant changes incorporated in this revision include the following:

- a) Provisions for spatial and environmental consideration in building design; and operable windows and UV exposure have been added.
- b) The aims of good lighting clause have been updated.
- c) Table 5 for illuminance and lighting performance parameters has been updated.
- d) Provisions for planning and design guidelines for circadian lighting and outdoor lighting have been introduced.
- e) Detailed provisions on design charts for natural ventilation and acceptable air temperature with the increase in the air speed have been added.
- f) The clause on aspects of daylighting has been updated.
- g) Orientation of building clause has been renamed to site planning and building placement.
- h) Terminology clause has been updated with new terms and definitions.

The provisions of this Section are without prejudice to the various acts, rules and regulations including the *Factories Act*, 1948 and rules and regulations framed thereunder.

The information contained in this Section is largely based on the following Indian Standards/Special Publications:

IS 2440 : 1975	Guide for daylighting of buildings ( <i>second revision</i> )
IS 3103 : 1975	Code of practice for industrial ventilation ( <i>first revision</i> )
IS 3362 : 1977	Code of practice for natural ventilation of residential buildings ( <i>first revision</i> )
IS 3646 (Part 1) : 202X	Code of practice for interior illumination : Part 1 General requirements and recommendations for working interiors ( <i>third revision</i> ) ( <i>under preparation</i> )
IS 7662 (Part 1) : 1974	Recommendations for orientation of buildings : Part 1 Non-industrial buildings
IS 11907 : 1986	Recommendations for calculation of solar radiation on buildings
SP 32 : 1986	Handbook on functional requirements of industrial buildings (lighting and ventilation)

SP 41 : 1987

Handbook on functional requirements of buildings  
other than industrial buildings

Provisions given in National Lighting Code, 'SP 72 : 2010' (*under revision*) may also be referred.

Assistance has been made from the following documents in revision of this Section:

Report on Energy Conservation in Buildings, submitted to Department of Power, Ministry of Energy by CSIR-Central Building Research Institute, Roorkee.

Adaptive thermal comfort model based on fields studies in five climate zones across India. *Building and Environment*, Volume 219, 1 July 2022 by Rawal, R., Shukla, Y., Vardhan, V., et al. (2022)

Field studies of thermal comfort across multiple climate zones for the subcontinent: India Model for Adaptive Comfort (IMAC). *Building and Environment*, 98(March 2106), (pp. 55–70) by Manu, S., Shukla, Y., Rawal, R., Thomas, L. E., & De Dear, R. (2016)

'Low Energy Cooling and Ventilation for Indian Residences: Design Guide.' Loughborough University, UK and CEPT Research and Development Foundation (CRDF), India by Cook, M., Shukla, Y., Rawal, R., Loveday, D., Faria, L. C., & Angelopoulos, C. (2020).

All standards, whether given herein above or cross-referred to in the main text of this Section, are subject to revision. The parties to agreement based on this Section are encouraged to investigate the possibility of applying the most recent editions of the standards.

For the purpose of deciding whether a particular requirement of this Section is complied with, the final value, observed or calculated, expressing the result of a test or analysis, shall be rounded off in accordance with IS 2 : 2022 'Rules for rounding off numerical values (*second revision*)'. The number of significant places retained in the rounded off value should be the same as that of the specified value in this Section.

**Members are requested to share their inputs/comments on the draft particularly w.r.t the changes listed above in the foreword; and specially on those text highlighted in yellow in this draft.**

### Important Explanatory Note for Users of the Code

In any Part/Section of this Code, where reference is made to **'good practice'** in relation to **design, constructional procedures or other related information**, and where reference is made to **"accepted standard"** in relation to **material specification, testing, or other related information**, the Indian Standards listed at the end of the Part/Section shall be used as a guide to the interpretation.

At the time of publication, the editions indicated in the standards were valid. All standards are subject to revision and parties to agreements based on any Part/ Section are encouraged to investigate the possibility of applying the most recent editions of the standards.

In the list of standards given at the end of a Part/Section, the number appearing within parentheses in the first column indicates the number of the reference of the standard in the Part/Section. For example:

a) Good practices [8-1(1)] refers to the Indian Standard(s) give at serial number (1) of the list of standards given at the end of this Part/Section, that is, 7662 (Part 1) : 1974 'Recommendations for orientation of buildings : Part 1 Non-industrial buildings'



**DRAFT FOR COMMENTS ONLY**

*(Not to be reproduced without the permission of BIS or used as a Standard)*

*Draft Indian Standard*

**National Building Code of India**

**Part 8 Building Services**

**Section 1 Lighting and Natural Ventilation**

[Fourth Revision of SP 7 (Part 8 Section 1)]

(ICS No. 01.120: 91.040.01)

---

**Technical Committee**

**Last Date for Comments:**

**National Building Code, CED 46**

**07 April 2025**

---

**1 SCOPE**

**1.1** This Code (Part 8/Section 1) covers requirements and methods for lighting and natural ventilation of buildings.

**1.2** The provisions in respect of lighting and ventilation in sustainable buildings are covered in Part 11 'Approach to Sustainability' of the Code which shall be used in conjunction with this Section.

**1.3** For all buildings and facilities open to and used by the public, including all forms of public housing by the government/civic bodies and private developers, **adequate lighting and natural ventilation** for barrier-free access and movement within and around buildings by elderly and persons with disabilities and of different age groups shall be ensured in accordance with Part 3 'Development Control Rules and General Building Requirements' of the Code. The ventilation through the building envelope elements such as windows, skylights, ventilators for thermal comfort and better air quality requirements are included in this section.

**2 TERMINOLOGY**

For the purpose of this Section, the following definitions shall apply.

**2.1 Lighting**

**2.1.1 Altitude ( $\theta$ )** – The angular distance of any point of celestial sphere, measured from the horizon, on the great circle passing through the body and the zenith (see Fig. 1).

**2.1.2 Azimuth ( $\Phi$ )** – The angle measured between meridians passing through the north point and the point in question (point C in Fig. 1).

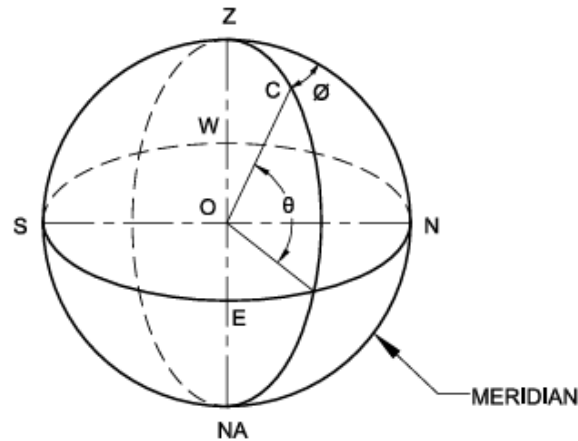

## REFERENCES

O - Observer's station	S - Geographical south
C - Celestial body	E - Geographical east
Z - Zenith	W - Geographical west
NA - Nadir	N - Geographical north

FIG. 1 ALTITUDE AND AZIMUTH OF A CELESTIAL BODY

**2.1.3 Brightness Ratio or Contrast** – The variations or contrast in brightness of the details of a visual task, such as white print on blackboard.

**2.1.4 Candela (cd)** – The SI unit of luminous intensity.

$$\text{Candela} = 1 \text{ lumen per steradian}$$

**2.1.5 Central Field** – The area of circle around the point of fixation and its diameter, subtending an angle of about 2 degrees at the eye. Objects within this area are most critically seen in both their details and colour.

**2.1.6 Clear Design Sky** – The distribution of luminance of such a sky is non-uniform; the horizon can be brighter than the zenith depending on the sun position, and when  $L_z$  is the brightness at zenith, the brightness at an altitude ( $\theta$ ) in the region away from the sun, is given by the expression:

$$L_\theta = L_z \operatorname{cosec} \theta \text{ (for } 15^\circ < \theta \leq 90^\circ \text{)}$$

$$L_\theta = L_z \operatorname{cosec} 15^\circ \text{ (for } 0^\circ \leq \theta \leq 15^\circ \text{)} = 3.8637 L_z$$

**2.1.7 Circadian Lighting** – Retinal ganglion cells, particularly those containing melanopsin, exhibit peak light sensitivity around 480 nm (cyan). 'Blue rich' light (460 nm to 495 nm), known as biologically active or circadian light, influences our biological rhythms. This influence is quantified using the melanopic daylight efficacy ratio (melanopic DER) and melanopic equivalent daylight illuminance (melanopic EDI). Effective lighting design for circadian support considers both the melanopic DER of an artificial light source and the total amount of melanopic EDI reaching the eye.

**2.1.8 Colour Rendering Index (CRI)** – Measure of the degree to which the psychophysical colour of an object illuminated by the test illuminant conforms to that of the same object illuminated by the reference illuminant, suitable allowance having been made for the state of chromatic adaptation.

**2.1.9 Correlated Colour Temperature (CCT) (K)** – The temperature of the Planckian radiator whose perceived colour most closely resembles that of a given stimulus at the same brightness and under specified viewing conditions.

**2.1.10 Daylighting** – The use of natural optical radiation from the sun and sky to illuminate interior spaces, providing both visual comfort and contributing to the regulation of the human circadian cycle. In this context, daylight refers to the portion of solar radiation that falls within the visible spectrum, specifically between 380 nm and 780 nm. Daylighting is designed to optimize the use of natural light to reduce artificial lighting needs while enhancing occupant well-being.

**2.1.11 Daylight Area** – Portion of a space where the working plane receives natural light with an illuminance level not less than the specified daylight factor or sufficient illuminance level. This area is defined by the relevant daylight factor contour.

**2.1.12 Daylight Factor** – The ratio, expressed as a percentage, of the illuminance at a specific point on a given plane indoors to the simultaneous illuminance on a horizontal plane outdoors under an overcast sky. This factor measures the amount of daylight reaching the indoor point relative to outdoor conditions, providing an indication of natural light availability in interior spaces.

**2.1.13 Daylight Penetration** – The maximum distance to which a given daylight factor contour penetrates into a room.

**2.1.14 Direct Solar Illuminance** – The illuminance from the sun without taking into account the light from the sky.

**2.1.15 External Reflected Component (ERC)** – Daylight illuminance at a point which is received by direct reflection from external surfaces

**2.1.16 Glare** – A condition of vision in which there is discomfort or a reduction in the ability to see significant objects or both due to an unsuitable distribution or range of luminance or due to extreme contrasts in space.

**2.1.17 Illuminance** – At a point on a surface, the ratio of the luminous flux incident on an infinitesimal element of the surface containing the point under consideration to the area of the element.

NOTE – The unit of illuminance (the measurement of illumination) is lux which is 1 lumen per m<sup>2</sup>.

**2.1.18 Indoor Artificial Lighting** – Artificial lighting with the use of electricity designed to enhance visual comfort, performance, and well-being within indoor spaces. Its effectiveness is evaluated using several factors:

- a) **Spectral Power Density (SPD)** – A measure of the light spectrum distribution, indicating how different wavelengths contribute to the overall lighting and its effects on human perception and biological responses.
- b) **Colour Tuning** – The adjustment of light's color temperature and spectral composition to suit visual tasks or mood, influencing both visual and non-visual responses like circadian regulation.
- c) **Light Flicker** – Light flicker, characterized by rapid and often imperceptible fluctuations in light intensity, can induce visual discomfort, strain, and reduced performance. The  $P_{st}^{LM}$  value, where "st" denotes "short term" and "LM" signifies "light flicker meter method," is employed to quantify visible flicker in lighting products.
- d) **Unified Glare Rating (UGR)** – A metric used to quantify the level of discomfort caused by glare in indoor environments, helping to ensure visual comfort without compromising the ability to perform tasks effectively.

**2.1.19 Internal Reflected Component (IRC)** – Daylight illuminance at a point in a given plane which is received by direct reflection or inter-reflection from the internal surfaces

**2.1.20 Light Output Ratio (LOR) or Efficiency ( $\eta$ )** – The ratio of the luminous flux emitted from the luminaire to that emitted from the lamp(s) (nominal luminous flux). It is expressed in percent.

**2.1.21 Light Pipe** – A conduit made of a highly reflective material, which is capable of channeling light from one end to the other through successive internal reflections. Such a pipe may be flexible or rigid.

**2.1.22 Light Shelf** – A daylighting system based on sun path geometry used to bounce the light off a ceiling, project it deeper into a space, distribute it from above, and diffuse it to produce a uniform light level below.

**2.1.23 Lumen ( $lm$ )** – SI unit of luminous flux. The luminous flux emitted within unit solid angle (one steradian) by a point source having a uniform intensity of one candela.

**2.1.24 Luminance (At a point of a Surface in a Given Direction) (Brightness)** – The quotient of the luminous intensity in the given direction of an infinitesimal element of the surface containing the point under consideration by the orthogonally projected area of the element on a plane perpendicular to the given direction. The unit is candela per square metre ( $cd/m^2$ ).

**2.1.25 Luminous Flux ( $\phi$ )** – The quantity characteristic of radiant flux which expresses its capacity to produce visual sensation evaluated according to the values of relative luminous efficiency for the light adapted eye:

- a) **Effective Luminous Flux ( $\phi_h$ )** – Total luminous flux which reaches the working plane.
- b) **Nominal Luminous Flux ( $\phi_o$ )** – Total luminous flux of the light sources in the interior.

**2.1.26 Maintenance Factor ( $d$ )** – The ratio of the average illuminance on the working plane after a certain period of use of a lighting installation to the average illuminance obtained under the same conditions for a new installation.

**2.1.27 Meridian** – It is the great circle passing through the zenith and nadir for a given point of observation.

**2.1.28 North and South Points** – The point in the respective directions where the meridian cuts the horizon.

**2.1.29 Orientation of Buildings** – In the case of non-square buildings, orientation refers to the direction of the normal to the long axis. For example, if the length of the building is east-west, its orientation is north-south.

**2.1.30 Outdoor Artificial Lighting** – Lighting systems designed for outdoor environments, aiming to provide visibility and safety while minimizing environmental impact. Key aspects include:

- a) **Fully Shielded** – Fixtures designed to direct all light downward, preventing upward light emissions and reducing glare or light pollution.
- b) **Full Cut-Off** – A lighting design where no light is emitted above the horizontal plane of the fixture, reducing sky glow and improving lighting efficiency.
- c) **Light Trespass** – The unwanted or excessive spillover of light into areas where it is not needed, such as neighbouring properties, which can cause discomfort and reduce privacy.
- d) **Sky Glow** – The brightening of the night sky caused by artificial lighting, which diminishes the visibility of stars and natural darkness, often exacerbated by poorly designed outdoor lighting.

**2.1.31 Peripheral Field** – It is the rest of the visual field which enables the observer to be aware of the spatial framework surrounding the object seen.

NOTE – A central part of the peripheral field, subtending an angle of about 30° on either side of the point of fixation, is chiefly involved in the perception of glare.

**2.1.32 Reflected Glare** – The adverse impact on visual comfort and efficiency caused by unwanted reflections in the task area, which can hinder the ability to see clearly or cause discomfort, regardless of the source of the glare.

**2.1.33 Surface Reflectance (Reflectance)** – The ratio of the luminous flux reflected by an opaque surface (with or without diffusion) to the flux it receives. Here the term is used for lighting. Some symbols used for surface reflectance of common indoor surfaces are:

- $r_c$  = reflection factor of ceiling.  
 $r_w$  = reflection factor of parts of the wall between the working surface and the luminaires.  
 $r_f$  = reflection factor of floor.

**2.1.34 Reveal** – The side of an opening for a window.

**2.1.35 Room Index ( $k_r$ )** – An index relating to the shape of a rectangular interior, according to the formula:

$$k_r = \frac{L.W}{(L+W)H_m}$$

where  $L$  and  $W$  are the length and width respectively of the interior, and  $H_m$  is the mounting height, that is, height of the fittings above the working plane.

#### NOTES

- 1 For rooms where the length exceeds 5 times the width,  $L$  shall be taken as  $L = 5W$ .
- 2 If the surface reflectance of the upper stretch of the walls is less than half the surface reflectance of the ceiling, for indirect or for the greater part of indirect lighting, the value  $H_m$  is measured between the ceiling and the working plane.

**2.1.37 Sky Component (SC)** –daylight illuminance at a point on a given plane which is received directly from the sky

**2.1.38 Solar Load** – The amount of heat received into a building due to solar radiation which is affected by orientation, materials of construction and reflection of external finishes and colour.

**2.1.39 Utilization Factor (Coefficient of Utilization) ( $\mu$ )** – The ratio of the total luminous flux which reaches the working plane (effective luminous flux,  $\phi_n$ ) to the total luminous flux of the light sources in the interior (nominal luminous flux,  $\phi_0$ ).

**2.1.40 UV-A** – Ultraviolet radiation with wavelengths between 315 and 400 nm. It penetrates the skin more deeply and plays a role in skin aging and DNA damage, but is less effective for germicidal purposes

**2.1.41 UV-B** – Ultraviolet radiation with wavelengths between 280 and 315 nm. It is effective in promoting the synthesis of pre-vitamin D3 in the human skin

**2.1.42 Visual Field** – The visual field in the binocular which includes an area approximately 120° vertically and 160° horizontally centering on the point to which the eyes are directed. The line joining the point of fixation and the centre of the pupil of each eye is called its primary line of sight.

**2.1.43 Working Plane** – A horizontal plane at a level at which work will normally be done (see 4.1.4.3 and 4.1.4.4).

## 2.2 Ventilation

**2.2.1 Air Change per Hour** – The amount of air leakage into or out of a building or room in terms of the number of building volume or room volume exchanged.

**2.2.2 Axial Flow Fan** – A fan having a casing in which the air enters and leaves the impeller in a direction substantially parallel to its axis.

**2.2.3 Centrifugal Fan** – A fan in which the air leaves the impeller in a direction substantially at right angles to its axis.

**2.2.4 Contaminants** – Dusts, fumes, gases, mists, vapours and such other substances present in air that are likely to be injurious or offensive to the occupants.

**2.2.5 Dilution Ventilation** – Supply of outside air to reduce the airborne concentration of contaminants in the building.

**2.2.6 Dry Bulb Temperature** – The temperature of the air, read on a thermometer, taken in such a way so as to avoid errors due to radiation.

**2.2.7 Effective Temperature (ET)** – An arbitrary index which combines into a single value the effect of temperature, humidity and air movement on the sensation of warmth or cold felt by the human body and its numerical value is that of the temperature of still saturated air which would induce an identical sensation.

**2.2.8 Exhaust of Air** – Removal of air from a building or a room and its disposal outside by means of a mechanical device, such as a fan.

**2.2.9 Fresh Air or Outside Air** – Air of that quality, which meets the criteria of Table 1 and in addition shall be such that the concentration of any contaminant in the air is limited to within one-tenth the threshold limit value (TLV) of that contaminant.

#### NOTES

- 1 Where it is reasonably believed that the air of quality is not expected as indicated above, sampling and analysis shall be carried out by a competent authority having jurisdiction and if the outside air of the specified quality is not available, filtration and other treatment devices shall be used to bring its quality to or above the levels mentioned in Table 1.

Odour is to be essentially unobjectionable.

- 2 The above list of contaminants is not exhaustive and available special literature may be referred for data on other contaminants.

**Table 1 Maximum Allowable Contaminant Concentrations  
for Ventilation Air  
(Clause 2.2.9)**

SI No.	Contaminants	Annual Average (Arithmetic Mean) µg/m <sup>3</sup>	Short Term Level (Not to Exceed More than Once a Year) µg/m <sup>3</sup>	Averaging Period h
(1)	(2)	(3)	(4)	(5)
i)	Suspended particulates	60	150	24
ii)	Sulphur oxides	80	400	24
iii)	Carbon monoxide	20 000	30 000	8
iv)	Photochemical oxidant	100	500	1
v)	Hydrocarbons (not including methanes)	1 800	4 000	3
vi)	Nitrogen oxide	200	500	24

**2.2.10 General Ventilation** – Ventilation, either natural or mechanical or both, so as to improve the general environment of the building, as opposed to local exhaust ventilation for contamination control.

**2.2.11 Globe Temperature** – The temperature measured by a thermometer whose bulb is enclosed in a matt black painted thin copper globe of 150 mm diameter. It combines the influence of air temperature and thermal radiations received or emitted by the bounding surfaces.

**2.2.12 Humidification** – The process whereby the absolute humidity of the air in a building is maintained at a higher level than that of outside air or at a level higher than that which would prevail naturally.

**2.2.13 Humidity, Absolute** – The mass of water vapour per unit volume.

**2.2.14 Humidity, Relative** – The ratio of the partial pressure or density of the water vapour in the air to the saturated pressure or density respectively of water vapour at the same temperature.

**2.2.15 Local Exhaust Ventilation** – Ventilation effected by exhaust of air through an exhaust appliance, such as a hood with or without fan located as closely as possible to the point at which contaminants are released, so as to capture effectively the contaminants and convey them through ducts to a safe point of discharge.

**2.2.16 Make-up Air** – Outside air supplied into a building to replace the indoor air.

**2.2.17 Mechanical Ventilation** – Supply of outside air either by positive ventilation or by infiltration by reduction of pressure inside due to exhaust of air, or by a combination of positive ventilation and exhaust of air.

**2.2.18 Natural Ventilation** – Supply of outside air into a building through window or other openings due to wind outside and convection effects arising from temperature or vapour pressure differences (or both) between inside and outside of the building.

**2.2.19 Positive Ventilation** – The supply of outside air by means of a mechanical device, such as a fan.

**2.2.20 Propeller Fan** – A fan in which the air leaves the impeller in a direction substantially parallel to its axis designed to operate normally under free inlet and outlet conditions.

**2.2.21 Spray-head System** – A system of atomizing water so as to introduce free moisture directly into a building.

**2.2.22 Stack Effect** – Convection effect arising from temperature or vapour pressure difference (or both) between outside and inside of the room and the difference of height between the outlet and inlet openings.

**2.2.23 Tropical Summer Index (TSI)** – The temperature of calm air at 50 percent relative humidity which imparts the same thermal sensation as the given environment.



**2.2.24 Threshold Limit Value (TLV)** – Refers to air-borne concentration of contaminants currently accepted by the American Conference of Governmental Industrial Hygienists and represents conditions under which it is believed that nearly all occupants may be repeatedly exposed, day after day, without adverse effect.

**2.2.25 Velocity, Capture** – Air velocity at any point in front of the exhaust hood necessary to overcome opposing air currents and to capture the contaminants in air at that point by causing the air to flow into the exhaust hood.

**2.2.26 Ventilation** – Supply of outside air into, or the removal of inside air from an enclosed space.

**2.2.27 Wet Bulb Temperature** – The steady temperature finally given by a thermometer having its bulb covered with gauze or muslin moistened with distilled water and placed in an air stream of not less than 4.5 m/s.

### 3 SITE PLANNING AND BUILDING PLACEMENT

**3.1** The aim of site planning and building placement for optimum building orientation is to provide physically and psychologically comfortable living inside the building by creating conditions which suitably and successfully ward off the undesirable effects of severe weather to a considerable extent by judicious use of the recommendations and knowledge of climatic factors.

#### 3.2 Climate Zones

**3.2.1** For the purpose of design of buildings, the country may be divided into the major climatic zones as given in Table 2, which also gives the basis of this classification.

**Table 2 Classification of Climate**  
(Clause 3.2.1)

SI No. (1)	Climatic Zone (2)	Mean Monthly Maximum Temperature °C (3)	Mean Monthly Relative Humidity Percent (4)
i)	Hot-dry	above 30	below 55
ii)	Warm-humid	above 30 above 25	above 55 above 75
iii)	Temperate	25-30	below 75
iv)	Cold	below 25	all values
v)	Composite		see 3.2.2

The climatic classification map of India is shown in Fig. 2.

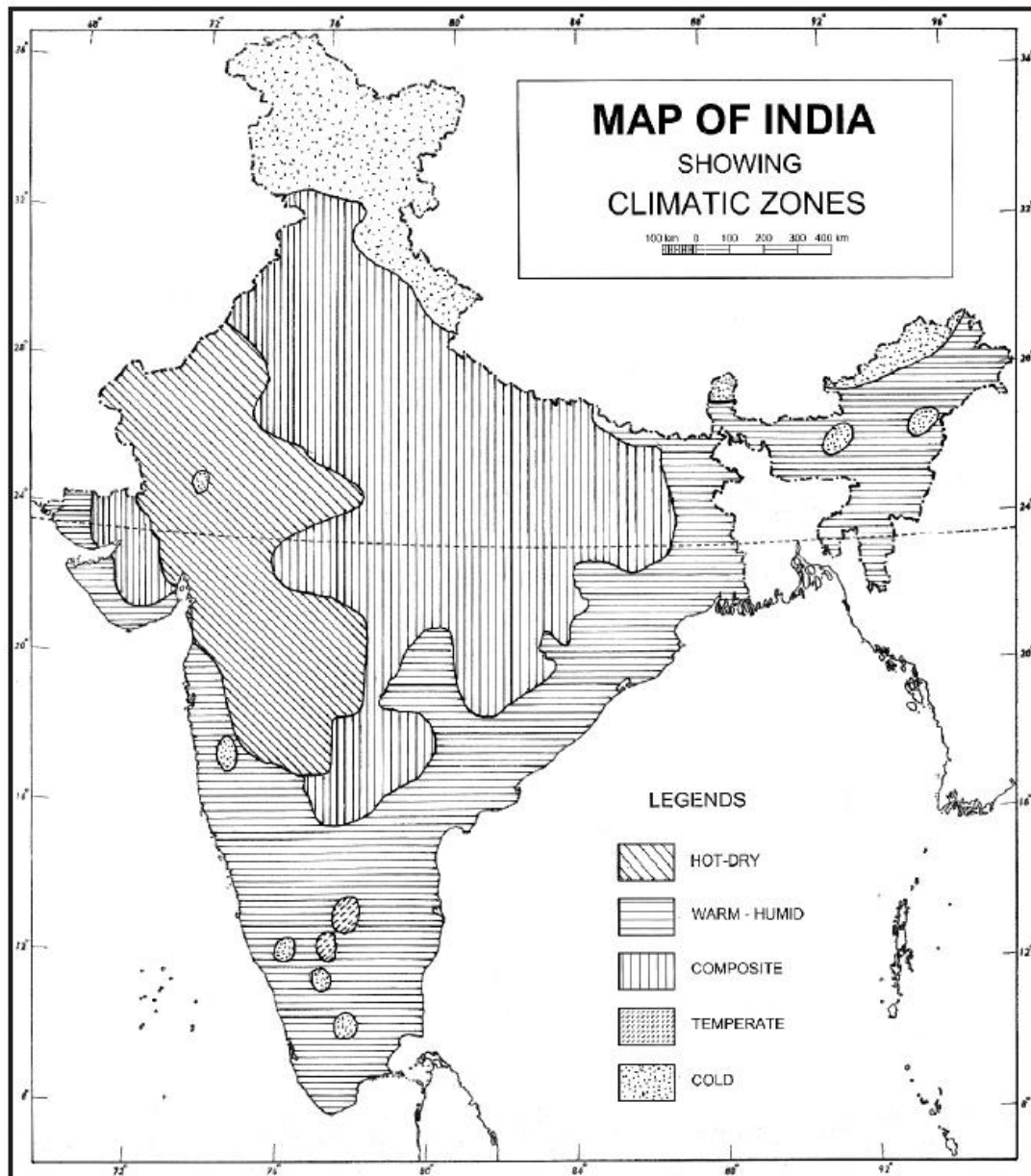

Based upon Survey of India Outline Map printed in 1993.

© Government of India Copyright, 2005

The territorial waters of India extend into the sea to a distance of twelve nautical miles measured from the appropriate base line.

The boundary of Meghalaya shown on this map is as interpreted from the North-Eastern Areas (Reorganisation) Act, 1971, but has yet to be verified.

Responsibility for correctness of internal details shown on the map rests with the publisher.

The state boundaries between Uttaranchal & Uttar Pradesh, Bihar & Jharkhand and Chhatisgarh & Madhya Pradesh have not been verified by Governments concerned.

FIG. 2 MAP OF INDIA SHOWING CLIMATIC ZONES

**3.2.2** Each climatic zone does not have same climate for the whole year; it has a particular season for more than six months and may experience other seasons for the remaining period. A climatic zone that does not have any season for more than six months may be called as composite zone.

### 3.3 Climatic Factors

From the point of view of lighting and natural ventilation, the following climatic factors influence the optimum orientation of the building:

- a) Solar radiation and temperature,
- b) Relative humidity, and
- c) Prevailing winds.

### 3.4 Solar Radiation

**3.4.1** The best orientation from a solar point of view requires that the building as a whole should receive the maximum solar radiation in winter and the minimum in summer. For practical evaluation, it is necessary to know the duration of sunshine, and hourly solar intensity on the various external surfaces on representative days of the seasons. The total direct plus diffused diurnal solar loads per unit area on the vertical surface facing different directions are given in Table 3 for two days in the year, that is, 22 June and 22 December, representative of summer and winter, for latitudes corresponding to some important cities all over India. From Table 3, the total heat intake can be calculated for all possible orientations of the building for these extreme days of summer and winter. Solar load on vertical surfaces of different orientations can be calculated as per the method given in Annex A.

**3.4.1.1** Except in cold climatic zone, suitable sun-breakers have to be provided to cut off the incursion of direct sunlight to prevent heat radiation and to avoid glare. A location (latitude) and weather specific approach to sizing of shading devices should consider the annual start and end date of the summer season for the building. Table 3 shows irradiation ( $W/m^2$ ) received per unit of the façade area in each orientation. Irradiation values maybe used for prioritizing shading devices and other measures of solar protection (for example, planting of vegetation).

**Table 3 Total Solar Radiation (Direct plus diffused) Incident on Various Surfaces of Buildings, in  $W/m^2/day$ , for Summer and for Winter Seasons**  
(Clause 3.4.1)

SI No.	Orientation		Latitude					
			9°N	13°N	17°N	21°N	25°N	29°N
(1)	(2)	(3)	(4)	(5)	(6)	(7)	(8)	(9)
i)	North	Summer	1 494	1 251	2 102	1 775	2 173	1 927
		Winter	873	859	840	825	802	765
ii)	North-East	Summer	2 836	2 717	3 144	3 092	3 294	3 189
		Winter	1 240	1 158	1 068	1 001	912	835
iii)	East	Summer	3 344	3 361	3 475	3 598	3 703	3 794
		Winter	2 800	2 673	2 525	2 409	2 211	2 055
iv)	South-East	Summer	2 492	2 660	2 393	2 629	2 586	2 735
		Winter	3 936	3 980	3 980	3 995	3 892	3 818
v)	South	Summer	1 009	1 185	1 035	1 117	1 112	1 350
		Winter	4 674	4 847	4 958	5 059	4 942	4 981
vi)	South-West	Summer	2 492	2 660	2 393	2 629	2 586	2 735
		Winter	3 936	3 980	3 980	3 995	3 892	3 818
vii)	West	Summer	3 341	3 361	3 475	3 598	3 703	3 794

SI No.	Orientation	Latitude						
		9°N	13°N	17°N	21°N	25°N	29°N	
(1)	(2)	(3)	(4)	(5)	(6)	(7)	(8)	(9)
viii)	North-West	Winter	2 800	2 673	2 525	2 409	2 211	2 055
		Summer	2 836	2 717	3 144	3 092	3 294	3 189
ix)	Horizontal	Winter	1 240	1 158	1 068	1 001	912	835
		Summer	8 107	8 139	8 379	8 553	8 817	8 863
		Winter	6 409	6 040	5 615	5 231	4 748	4 281

### 3.5 Relative Humidity and Prevailing Winds

**3.5.1** The discomfort due to high relative humidity in air when temperatures are also high can be counteracted, to a great extent, by circulation of air with electric fans or by ventilation. In the past, simultaneously with heavy construction and surrounding *Verandahs* to counter the effect of sun's radiation, there was also an over emphasis on prevailing winds to minimise the adverse effects of high humidity with high temperatures. With the introduction of electric fan to effectively circulate air and owing to taking into account the rise in cost of construction of buildings, emphasis should be on on protection from solar radiation where temperatures are very high. When, however, there is less diurnal variation between morning and mean maximum temperatures along with high humidity, as in coastal areas, the emphasis should be on prevailing winds.

**3.5.1.1** For the purpose of orientation, it is necessary to study the velocity and direction of the wind at each hour and in each month instead of relying on generalizations of a month or a period or for the year as a whole. This helps to spot the right winds for a particular period of day or night.

**3.5.1.2** It is generally found that variation up to 30° with respect to the prevalent wind direction does not materially affect indoor ventilation (average indoor air speed) inside the building.

**3.5.2** In hot-dry climate, advantage can be taken of evaporative cooling in summer to cool the air before introducing it into the building. But in warm humid climate, it is desirable either to regulate the rate of air movement with the aid of electric fans or to take advantage of prevailing winds.

### 3.6 Aspects of Daylighting

The clear design sky concept accounts for the worst-case scenario, making building orientation less critical, except for the need to avoid direct sunlight and glare. However, mutual shading effects from opposite facades and significant vegetation elements shall be considered to maintain effective daylighting. Glare control should be referenced from Part 11 'Approach to Sustainability' of this code. Daylighting design is supported by three key pillars: daylight availability, sun control, and glare control, all of which are essential to ensure optimal visual comfort and energy efficiency within buildings.

### 3.7 Spatial and Environmental Considerations in Building Design

Sustainable building design focuses on optimizing the use of natural resources, improving energy efficiency, and ensuring occupant well-being. Integrating natural elements such as vegetation and considering the spatial relationships between buildings play a crucial role in enhancing daylight access, ventilation, and thermal comfort, while promoting ecological balance.

The following considerations shall guide the integration of these elements into building design:

- a) Vegetation that matches or exceeds the building height shall be incorporated into the site design to enhance both aesthetic and environmental impacts. This vegetation should provide visual harmony with the surrounding landscape and offer ecological benefits, such as shading, improved air quality, and reduced heat island effect.
- b) Adequate spacing between a building and neighbouring structures is essential for ensuring access to natural light, ventilation, and privacy. The distance between buildings shall be planned to minimize overshadowing, reduce light trespass, and promote natural airflow, enhancing the overall livability of the area.
- c) The orientation of building facades relative to cardinal directions shall be planned to optimize solar gain, energy efficiency, and occupant comfort. Facades should maximize natural light while minimizing glare and overheating, contributing to overall energy efficiency and improving thermal performance.
- d) Tree planting in open spaces and streets shall be carefully planned to provide shade during the summer season, allow intermittent or seasonal sunlight access, without obstructing natural winds or compromise daylight access. The selected trees should reduce glare, create cool microclimates, and improve air quality. Deciduous trees that shed leaves in winter and retain thick foliage in summer are especially advantageous, particularly for southern and western exposures, allowing maximum sunlight in winter and providing effective shading in summer. Trees with high-density foliage and low gap percentages (for example, Asoka, Asopalav) shall be placed at a distance proportional to their mature height to avoid obstructing light and airflow. Less dense or deciduous trees (for example, Gulmohar, Amaltas, Neem) may be planted with considerations beyond daylight access, including aesthetics and ecological benefits.

### 3.8 Operable Windows and UV Exposure

Operable windows shall be provided in habitable spaces to allow for natural ventilation and daylighting. Most glazing types (single pane or double pane) block the UV part of the solar radiation to avoid over-exposure of interiors and occupants to damaging effects of UV radiation. However, some UV exposure has health benefits (UV-B for Vitamin D3 production) that occupants can only access if the glass windows are operable. Operable windows should be designed for maximum accessibility to for building occupants and direct sun access on facades that receive direct sun, operable windows shall be preferred from healthy daylight access point-of-view.

**3.9** For detailed information regarding orientation of buildings and recommendations for various climatic zones of country, reference may be made to good practice [8-1(1)].

## **4 LIGHTING**

### **4.1 Principles of Lighting**

#### *4.1.1 Aims of Good Lighting*

Good lighting is essential for all buildings and serves multiple purposes. Its primary aims are to create a comfortable, functional, and visually pleasing environment that supports human well-being. It should promote work and other activities within the building, ensure the safety of occupants, and, in harmony with the structure and decoration, foster a pleasant and engaging atmosphere. In addition, good lighting should consider human development, such as supporting eye growth and maintaining healthy circadian rhythms. Glare control is also critical, as excessive glare can cause discomfort, eye strain, and headaches. By managing glare effectively, lighting systems can enhance visual comfort, improve productivity, and contribute to an overall better quality of life for the occupants.

**4.1.1.1** Realization of these aims involves the following:

- a) Careful planning of the brightness and colour pattern within both the working areas and the surroundings so that attention is drawn naturally to the important areas, detail is seen quickly and accurately, and the room is free from any sense of gloom or monotony (see **4.1.4**).
- b) Using directional lighting where appropriate to assist perception of task detail and to give good modelling.
- c) Controlling direct and reflected glare from light sources to eliminate visual discomfort.
- d) In artificial lighting installations, minimizing flicker from certain types of lamps and paying attention to the colour rendering properties of the light.
- e) Correlating lighting throughout the building to prevent excessive differences between adjacent areas so as to reduce the risk of accidents.
- f) Installing emergency lighting systems, where necessary.

#### *4.1.2 Planning the Brightness Pattern*

The brightness pattern seen within an interior may be considered as composed of three main parts – the task itself, immediate background of the task and the general surroundings of walls, ceiling, floor, equipment and furnishings.

The illuminance requirements given in **13** of Part 3 'Development Control Rules and General Building Requirements' of the Code, for elders and persons with disabilities, shall be complied with in addition to the requirements specified in this Section

**4.1.2.1** In occupations where the visual demands are small, the levels of illumination derived from a criterion of visual performance alone may be too low to satisfy the other requirements. For such situations, therefore, illuminance recommendations are based on standards of welfare, safety and amenity judged appropriate to the occupations; they are also sufficient to give these tasks brightness which ensured that the visual performance exceeds the specified minimum.

**4.1.2.2** Where work takes place over the whole utilizable area of room, the illumination over that area should be reasonably uniform and it is recommended that the uniformity ratio (minimum illuminance divided by average illuminance levels) should be not less than 0.7 for the working area.

**4.1.2.3** To ensure visual comfort and minimize strain, the illuminance levels within a space should be carefully balanced. Large spatial variations in illuminance around the task or activity area shall be avoided, as they can lead to visual stress and discomfort. The illuminance of the immediate surrounding area shall be related to that of the task area or activity area, ensuring a well-balanced luminance distribution within the visual field. This immediate surrounding area shall be defined as a band with a minimum width of 0.5 m around the task area. While the illuminance of this surrounding area may be lower than that of the task area, it shall not fall below the minimum values specified in Table 4. Additionally, the size and position of the immediate surrounding area shall be clearly stated and documented in the lighting design specifications. Proper planning of these illuminance levels contributes to a visually comfortable and efficient built environment.

**Table 4 Relationship of Average Illuminances on Immediate Surrounding to the Average Illuminance on the Task Area or Activity Area**  
(Clause 4.1.2.3)

Sl. No.	Average Illuminance on the Task Area or Activity Area lx	Average Illuminance on Immediate Surrounding Areas lx
(1)	(2)	(3)
i)	≥ 750	500
ii)	500	300
iii)	300	200
iv)	200	150
v)	≤ 150	<i>equal to task area</i>

**4.1.2.4** In indoor workplaces, particularly those devoid of daylight, ensuring adequate illumination beyond the immediate task surroundings is essential for visual comfort and spatial perception. A large area outside the immediate surrounding area, referred to as the background area, shall be illuminated to maintain a well-balanced visual environment. The background area is a horizontal surface at floor level, adjacent to the immediate surrounding area within the limits of the space. It shall have a maintained average illuminance of at least one-third of the illuminance value of the immediate surrounding area. In larger rooms, this background area shall have a minimum width of 3 m to ensure uniformity in lighting. Proper illumination of the background area may help in reducing visual fatigue and enhancing overall workplace efficiency.

**4.1.2.5** In case of all buildings and facilities open to and used by the public, including all forms of public housing by the government/civic bodies and private developers, the requirements

for visual contrast as given in 13 and Annex B of Part 3 'Development Control Rules and General Building Requirements' of the Code shall also be complied with for ensuring visual comfort for elders and persons with disabilities.

#### 4.1.3 Glare

Excessive contrast or abrupt and large changes in brightness produce the effect of glare. When glare is present, the efficiency of vision is reduced and small details or subtle changes in scene cannot be perceived. It may be,

- a) direct glare due to light sources within the field of vision;
- b) reflected glare due to reflections from light sources or surfaces of excessive brightness; and
- c) veiling glare where the peripheral field is comparatively very bright.

**4.1.3.1** An example of glare sources in daylighting is the view of the bright sky through a window or skylight, especially when the surrounding wall or ceiling is comparatively dark or weakly illuminated. Glare can be minimized in this case either by shielding the open sky from direct sight by louvers, external hoods or deep reveals, curtains or other shading devices or by cross lighting the surroundings to a comparable level. A gradual transition of brightness from one portion to the other within the field of vision always avoids or minimizes the discomfort from glare.

For electric lamps the minimum shielding angles for lamp luminance shall not be less than the values given in the table below:

<i>Lamp Luminance</i> kcd/m <sup>2</sup>	<i>Minimum Shielding Angle</i> Degrees
1 to 20	10
20 to 50	15
50 to 500	20
≥ 500	30

The above mentioned shielding angle should not be applied to luminaries who do not appear in the field of view of a worker during usual work and/or do not give the worker any noticeable disability glare

Table 6 also gives recommended value of quality class of direct glare limitation for different tasks. These are numbers assigned to qualitative limits of direct glare; high, medium and low quality as 1, 2 and 3, respectively. For more details reference may be made to good practice [8–1(2)].

#### 4.1.4 Recommended Values of Illuminance

Table 6 gives **the illuminance and lighting performance parameters** commensurate with the general standards of lighting described in this Section and related to many occupations and buildings. These are valid under most of the conditions whether the illumination is by daylighting, artificial lighting or a combination of the two. The great variety of visual tasks makes it impossible to list them all and those given should be regarded as representing types of task.



The illuminance shall comply with the requirements given in Part 3 'Development Control Rules and General Building Requirements' of the Code for persons with disabilities, in addition to the requirements specified in Table 6.

#### 4.1.4.1 Composition of the tables

For the application of the Table 5 in 4.1.4 (see 4.1.4.1, 4.1.4.2 and 4.1.6).

- a) Col 1 lists the reference number for each task area or activity area.
- b) Col 2 lists those tasks areas or activities areas, for which specific requirements are given. If the particular task or activity is not listed, the values given for a similar, comparable situation should be adopted. Task areas or activity areas can also be a room, for example a corridor or resting room.
- c) Col 3 gives the required maintained average illuminance  $\bar{E}_m$  on the reference surface (see 4.1.7) for the interior (area) in which the task or activity from Col 2 is performed.
- d) Col 4 gives the minimum illuminance uniformity  $U_o$  on the reference surface for the maintained average illuminance  $\bar{E}_m$  chosen according to 5.
- j) Col 5 gives the minimum colour rendering indices ( $R_a$ ) (see 4.1.8) for the situation listed in Col 2.
- m) Col 6 gives the UGR limits (Unified Glare Rating limit,  $R_{UGL}$ ) that are applicable to the situation listed in Column 2 (see 4.1.3).
- n) Col 7 gives the maintained cylindrical illuminance  $\bar{E}_{m,z}$  for the recognition of object and people .
- o) Col 8 gives the maintained average illuminance on walls  $\bar{E}_{m, wall}$ .
- p) Col 9 gives the maintained average illuminance on ceilings  $\bar{E}_{m, ceiling}$ .

4.1.4.2 The different locations and tasks are grouped as per the following:

Sl No.	Location	Tasks
i)	Traffic zones inside buildings	
ii)	General areas inside buildings	Rest, sanitation and first aid rooms Control rooms Store rooms, cold stores
iii)	Logistics and warehouses	

SI No.	Location	Tasks
iv)	Industrial activities and crafts	Agriculture Bakeries Cement, cement goods, concrete, bricks Ceramics, tiles, glass, glassware Chemical, plastics and rubber industry Electrical and electronic industry Food stuffs and luxury food industry Foundries and metal casting Hairdressers Jewellery manufacturing Laundries and dry cleaning Leather and leather goods Metal working and processing Paper and paper goods Power stations Printers Rolling mills, iron and steel works Textile manufacture and processing Vehicle construction and repair Wood working and processing
v)	Offices	
vi)	Retail premises	
vii)	Places of public assembly	General areas Restaurants and hotels Theatres, concert halls, cinemas, places for entertainment Trade fairs, exhibition halls Museums Libraries Car parks (indoor)
viii)	Educational premises	Nursery school, play school Educational buildings
ix)	Health care premises	Rooms for general use Staff rooms Wards, maternity wards Examination rooms (general) Eye examination rooms Ear examination rooms Scanner rooms Delivery rooms Treatment rooms (general) Operating areas Intensive care unit Dentists Laboratories and pharmacies Decontamination rooms Autopsy rooms and mortuaries

SI No.	Location	Tasks
x)	Transportation areas	Airports Railway installations

**4.1.4.3** The illumination levels recommended in Table 5 are those to be maintained at all time on the task. As circumstances may be significantly different for different interiors used for the same application or for different conditions for the same kind of activity, a range of illuminances is recommended for each type of interior or activity instead of a single value of illuminance. Each range consists of three successive steps of the recommended scale of illuminances. They represent good practice and should be regarded as giving order of illumination commonly required rather than as having some absolute significance. For working interiors, the middle value of each range represents the recommended service illuminance that would be used unless one or more of the factors mentioned below apply.

**4.1.4.3.1** The higher value of the range should be used when,

- a) unusually low reflectances or contrasts are present in the task;
- b) errors are costly to rectify;
- c) visual work is critical;
- d) accuracy or higher productivity is of great importance; and
- e) visual capacity of the worker makes it necessary.

**4.1.4.3.2** The lower value of the range may be used when,

- a) reflectances or contrast are unusually high;
- b) speed and accuracy is not important; and
- c) the task is executed only occasionally.

**4.1.4.4** Where a visual task is required to be carried out throughout an interior, general illumination level to the recommended value on the working plane is necessary; where the precise height and location of the task are not known or cannot be easily specified, the recommended value is that on horizontal plane 850 mm above floor level.

NOTE – For an industrial task, working plane for the purpose of general illumination levels is that on a work place which is generally 750 mm above the floor level. For certain purposes, such as viewing the objects of arts, the illumination levels recommended are for the vertical plane at which the art pieces are placed.

**4.1.4.5** Where the task is localized, the recommended value is that for the task only; it need not, and sometimes should not, be the general level of illumination used throughout the interior. Some processes, such as industrial inspection process, call for lighting of specialized design, in which case the level of illumination is only one of the several factors to be taken into account.

**4.1.4.6** In case of all buildings and facilities open to and used by the public, including all forms of public housing by the government/civic bodies and private developers, the minimum illuminance level as given in 13 and Annex B of Part 3 'Development Control Rules and General Building Requirements' of the Code shall also be complied with for ensuring sufficient lighting for accessibility by elders and persons with disabilities.

#### 4.1.5 Lighting for Movement About a Building

Most buildings are complexes of working areas and other areas, such as passages, corridors, stairways, lobbies and entrances. The lighting of all these areas shall be properly correlated to give safe movement within the building at all times. In case of all buildings and facilities open to and used by the public, including all forms of public housing by the government/civic bodies and private developers, the illuminance in these areas shall comply with the requirements given in **13** and **Annex B** of Part 3 'Development Control Rules and General Building Requirements' of the Code.

##### 4.1.5.1 Corridors, passages and stairways

Sudden changes in lighting can be dangerous when moving from a well-lit work area to a dimly lit corridor, passage, or stairway, as the eyes need time to adjust. To enhance safety, these areas should have adequate illumination to ensure clear visibility. In spaces that are used occasionally, motion-sensing lights may be installed to conserve energy while still providing necessary lighting when needed. Additionally, stairways should be designed to minimize glare from direct light sources and prevent shadows that could cause confusion.

To further improve visibility, tread or strip lighting may be used to highlight steps, especially in dimly lit areas. This is particularly important in fire egress routes, where clear identification of steps can aid safe evacuation. Similarly, outdoor industrial catwalks and stairways should be well-lit, ensuring that lighting is positioned to avoid glare and provide consistent brightness. Implementing these measures can help prevent accidents and create a safer environment for movement through transitional spaces.

##### 4.1.5.2 Entrances

The problems of correctly grading the lighting within a building to allow adequate time for adaptation when passing from one area to another area are particularly acute at building entrances. These are given below:

- a) By day, people entering a building will be adapted to the very high levels of brightness usually present outdoors and there is risk of accident if entrance areas, particularly any steps, are poorly lighted. This problem may often be overcome by arranging windows to give adequate natural lighting at the immediate entrance, grading to lower levels further inside the entrance area. Where this cannot be done, supplementary artificial lighting should be installed to raise the level of illumination to an appropriate value.
- b) At night it is desirable to light entrance halls and lobbies so that the illumination level reduces towards the exit and so that no bright fittings are in the line of sight of people leaving the building. Any entrance steps to the building should be well-lighted by correctly screened fittings.

##### 4.1.6 Brightness Appearance of Rooms

To enhance the brightness appearance and visual comfort of rooms, it is important to define the task or activity areas within the space and assess the type of visual tasks performed. Appropriate lighting criteria, such as maintained average illuminance ( $\bar{E}_m$ ), uniformity ratio ( $U_0$ ), color rendering index ( $R_a$ ), and unified glare rating limit ( $R_{UGL}$ ), should be selected based

on the most demanding tasks. Key room surfaces, including walls and ceilings, should be illuminated to contribute to the perception of brightness. Higher illuminance levels in task areas may be considered to support better visual performance, while the illumination of objects and room surfaces, such as walls ( $\bar{E}_m$ , wall) and ceilings ( $\bar{E}_m$ , ceiling), should be optimized. In spaces with high ceilings or in industrial settings where ceiling lighting is less critical, a lower ceiling illuminance may be acceptable. Table 5 shows the assignment of columns to requirements, as informed in 4.1.4.1.

#### 4.1.7 Lighting Requirements for Task Areas, Activity Areas, Room and Space Brightness

The requirements for task areas and activity areas are given in Table 5. The requirements for the specific tasks and activities are given by  $\bar{E}_m$ ,  $U_o$ ,  $R_a$  and  $R_{UGL}$ . The requirements for the space in which the task(s) or activities are carried out are given by  $\bar{E}_{m,z}$  for the perception of objects and people within this space and  $\bar{E}_{m,wall}$  and  $\bar{E}_{m,ceiling}$  for room brightness. The latter are used for designing the room and the space including  $R_{UGL}$ . Glare (by  $R_{UGL}$ ) is dedicated to the space in which a task is carried out.

The first four columns are used for of task area or activity area design and more than one of these areas can occur within one space.

**Table 5 Assignment of Columns to Requirements**  
(Clause 4.1.6)

Sl. No.	Task area or activity area design				Room or space design requirements		
(1)	(2)				(3)		
i)	Task or activity related requirements				Brightness appearance of rooms (4.1.6)		
ii)	$\bar{E}_m$ lux	$U_o$	$R_a$	$R_{UGL}$	$\bar{E}_{m,z}$ lux	$\bar{E}_{m,wall}$ lux	$\bar{E}_{m,ceiling}$ lux

Where,

$\bar{E}_m$  – Minimum average illuminance level at defined area

$U_o$  – Uniformity ratio (Minimum illuminance / Average illuminance)

$R_a$  – Colour rendering properties of a light source

$R_{UGL}$  – Unified glare rating limit value

$\bar{E}_{m,z}$  – Maintained average cylindrical illuminance

$\bar{E}_{m, wall}$  – Average illuminance level at wall(s)

$\bar{E}_{m, ceiling}$  – Average illuminance level at ceiling

In all enclosed places the maintained illuminances on the major surfaces shall have the following values, unless specified in the table.

**Table 5 Illuminance and Lighting Performance Parameters**  
(Clauses 4.1.3.1, 4.1.4, 4.1.4.1, 4.1.4.2, 4.1.4.3, 4.3.2 and 4.3.2.1)

Sl. No.	Ref. No.	Type of task/activity area	$\bar{E}_m$ ( $L_x$ )	$U_o$	$R_a$	$R_{UGL}$	$\bar{E}_{m,z}$ ( $L_x$ )	$\bar{E}_{m,wall}$ ( $L_x$ )	$\bar{E}_{m,ceiling}$ ( $L_x$ )
(1)	(2)	(3)	(4)	(5)	(6)	(7)	(8)	(9)	(10)
	<b>1</b>	<b>Areas Inside Buildings</b>							
1)	1.1	Corridors and circulation areas	75-100-150	0.40	70	28	—	—	—
2)	1.2	Stairs, escalators, travelators	75-100-150	0.40	70	25	—	—	—
3)	1.3	Elevators, lifts	75-100-150	0.40	70	25	—	—	—
4)	1.4	Area in front of lifts, elevators and escalators	150-200-300	0.40	70	25	—	—	—
5)	1.5	Loading ramps/bays	100-150-200	0.40	70	25	—	—	—
6)	1.6	Building entrance with canopy	20-30-50	0.40	—	—	—	—	—
7)	1.7	Gangways: manned	100-150-200	0.40	70	25	—	—	—
	<b>2</b>	<b>General Areas Inside Buildings-Rest, Sanitation and First Aid Rooms</b>							
8)	2.1	Canteens and break areas	150-200-300	0.40	80	22	—	—	—
9)	2.2	Resting rooms	75-100-150	0.40	80	22	—	—	—
10)	2.3	Rooms for physical exercise	200-300-500	0.40	80	22	—	—	—
11)	2.4	Cloakroom (area), washrooms, bathrooms, dressing-, lockers-, shower, sink and toilet areas	150-200-300	0.40	80	25	—	—	—
12)	2.5	Facial lighting in front of mirrors	150-200-300	0.40	80	—	—	—	—
13)	2.6	Sick bay	300-500-750	0.60	80	19	—	—	—
14)	2.7	Rooms for medical attention	300- 500-750	0.60	90	19	—	—	—
15)	2.8	General cleaning	75-100-150	0.40	—	—	—	—	—
	<b>3</b>	<b>General Areas Inside Buildings-Control Rooms</b>							
16)	3.1	Plant rooms, switch gear rooms	150-200-300	0.40	80	25	50	50	—
17)	3.2	Post sorting, switchboard	300-500-750	0.60	80	19	150	150	—

Sl. No.	Ref. No.	Type of task/activity area	$\bar{E}_m$ ( $L_x$ )	$U_o$	$R_a$	$R_{UGL}$	$\bar{E}_{m,z}$ ( $L_x$ )	$\bar{E}_{m,wall}$ ( $L_x$ )	$\bar{E}_{m,ceiling}$ ( $L_x$ )
(1)	(2)	(3)	(4)	(5)	(6)	(7)	(8)	(9)	(10)
18)	3.3	Surveillance station	200-300-500	0.60	80	19	100	100	—
	<b>4</b>	<b>General Areas Inside Buildings-Store Rooms, Cold Stores</b>							
19)	4.1	Store and stockrooms	75 -100-150	0.40	80	25	—	—	—
20)	4.2	Dispatch packing handling areas	200-300-500	0.60	80	25	—	—	—
21)	4.3	Larder	150-200-300	0.40	80	25	—	—	—
	<b>5</b>	<b>Logistics and Warehouses</b>							
22)	5.1	Unloading/ loading area	150-200-300	0.40	80	25	50	—	—
23)	5.2	Packing/ grouping area	200-300-500	0.50	80	25	100	—	—
24)	5.3	Configuration and rehandling	500-750-1000	0.60	80	22	150	—	—
25)	5.4	Open goods storage	150-200-300	0.40	80	25	50	—	—
26)	5.5	Rack storage floor	100-150-200	0.50	80	25	—	—	—
27)	5.6	Rack storage rack face	50-75-100	0.40	80	—	—	—	—
28)	5.7	Central logistics corridor (heavy traffic)	200-300-500	0.60	80	25	100	—	—
29)	5.8	Automated zones (unmanned)	50-75-100	0.40	80	25	—	—	—
	<b>6</b>	<b>Industrial Activities and Crafts-Agriculture</b>							
30)	6.1	Loading and operating of goods, handling equipment and machinery	150-200-300	0.40	80	25	—	—	—
31)	6.2	Buildings for livestock	30-50-75	0.40	70	—	—	—	—
32)	6.3	Sick animal pens; calving stalls	150-200-300	0.60	80	25	—	—	—
33)	6.4	Feed preparation; dairy; utensil washing	150-200-300	0.60	80	25	—	—	—
	<b>7</b>	<b>Industrial Activities and Crafts – Bakeries</b>							



Sl. No.	Ref. No.	Type of task/activity area	$\bar{E}_m$ ( $L_x$ )	$U_o$	$R_a$	$R_{UGL}$	$\bar{E}_{m,z}$ ( $L_x$ )	$\bar{E}_{m,wall}$ ( $L_x$ )	$\bar{E}_{m,ceiling}$ ( $L_x$ )
(1)	(2)	(3)	(4)	(5)	(6)	(7)	(8)	(9)	(10)
34)	7.1	Preparation and baking	200-300-500	0.60	80	22	75	—	—
35)	7.2	Finishing, glazing, decorating	300-500-750	0.70	80	22	100	—	—
<b>8 Industrial Activities and Crafts-Cement, Cement Goods, Concrete, Bricks</b>									
36)	8.1	Drying	30-50-75	0.40	70	28	—	—	—
37)	8.2	Preparation of materials; work on kilns and mixers	150-200-300	0.40	70	28	50	—	—
38)	8.3	General machine work	200-300-500	0.60	80	25	100	—	—
39)	8.4	Rough forms	200-300-500	0.60	80	25	100	—	—
<b>9 Industrial Activities and Crafts-Ceramics, Tiles, Glass, Glassware</b>									
40)	9.1	Drying	30-50-75	0.40	70	28	—	—	—
41)	9.2	Preparation, general machine work	200-300-500	0.60	80	25	100	—	—
42)	9.3	Enamelling, rolling, pressing, shaping simple parts, glazing, glass blowing	200-300-500	0.60	80	25	100	—	—
43)	9.4	Grinding, engraving, glass polishing, shaping precision parts, manufacture of glass instruments	500-750-1000	0.70	80	19	150	75	50
44)	9.5	Grinding of optical glass, crystal, hand grinding and engraving	500-750-1000	0.70	80	19	150	75	50
45)	9.6	Precision work, for example decorative grinding, hand painting	750-1000-1000	0.70	90	19	150	75	50
46)	9.7	Manufacture of synthetic precious stones	1000-1500-2000	0.70	90	19	150	75	50
<b>10 Industrial Activities and Crafts-Chemical, Plastics and Rubber Industry</b>									

Sl. No.	Ref. No.	Type of task/activity area	$\bar{E}_m$ ( $L_x$ )	$U_o$	$R_a$	$R_{UGL}$	$\bar{E}_{m,z}$ ( $L_x$ )	$\bar{E}_{m,wall}$ ( $L_x$ )	$\bar{E}_{m,ceiling}$ ( $L_x$ )
(1)	(2)	(3)	(4)	(5)	(6)	(7)	(8)	(9)	(10)
47)	10.1	Remote- operated processing installations	30 -50-75	0.40	70	—	—	—	—
48)	10.2	Processing installations with limited manual intervention	100-150-200	0.40	70	28	50	—	—
49)	10.3	Constantly manned work stations in processing installations	200-300-500	0.60	80	25	100	—	—
50)	10.4	Precision measuring rooms, laboratories	300-500 - 750	0.60	80	19	150	75	50
51)	10.5	Precision measuring rooms, laboratories	300-500 - 750	0.60	80	19	150	75	50
52)	10.6	Pharmaceuti cal production	300-500 - 750	0.60	80	22	150	—	—
53)	10.7	Tyre production	300-500 - 750	0.60	80	22	150	—	—
54)	10.8	Colour inspection	750-1000-1500	0.70	90	19	150	75	50
55)	10.9	Cutting, finishing, inspection	500-750-1000	0.70	80	19	150	75	50
<b>11 Industrial Activities and Crafts-Electrical and Electronic Industry</b>									
56)	11.1	Cable and wire manufacture	200 -300-500	0.60	80	25	100	—	—
57)	11.2	Winding-large coils	200 -300-500	0.60	80	25	100	—	—
58)	11.3	Winding-medium-sized coils	300-500-750	0.60	80	22	150	—	—
59)	11.4	Winding-small coils	500-750-1000	0.70	80	19	150	75	50
60)	11.5	Coil impregnating	200 -300-500	0.60	80	25	100	—	—
61)	11.6	Galvanising	200 -300-500	0.60	80	25	100	—	—
62)	11.7	Assembly work:- rough, for example large transformers	200 -300-500	0.60	80	25	100	—	—
63)	11.8	Assembly work:- medium, for	300-500-750	0.60	80	22	150	—	—

Sl. No.	Ref. No.	Type of task/activity area	$\bar{E}_m$ ( $L_x$ )	$U_o$	$R_a$	$R_{UGL}$	$\bar{E}_{m,z}$ ( $L_x$ )	$\bar{E}_{m,wall}$ ( $L_x$ )	$\bar{E}_{m,ceiling}$ ( $L_x$ )
(1)	(2)	(3)	(4)	(5)	(6)	(7)	(8)	(9)	(10)
		example switchboards							
64)	11.9	Assembly work:- fine, for example telephones, radios, IT equipment (computers)	500-750-1000	0.70	80	19	150	75	50
65)	11.10	Assembly work:- precision, for example measuring equipment, printed circuit boards	750-1000-1500	0.70	80	19	150	75	50
66)	11.11	Electronic workshops, testing, adjusting	1000-1500-2000	0.70	80	19	150	75	50
<b>12 Industrial Activities and Crafts-Food Stuffs and Luxury Food Industry</b>									
67)	12.1	Work stations	150-200-300	0.40	80	25	50	—	—
68)	12.2	Sorting and washing of products, milling, mixing, packing	200-300-500	0.60	80	25	100	—	—
69)	12.3	Work stations and critical zones in slaughter houses, butchers, dairies mills, on filtering floor in sugar refineries	300-500-750	0.60	80	25	150	—	—
70)	12.4	Cutting and sorting of fruit and vegetables	200-300-500	0.60	80	25	100	—	—
71)	12.5	Manufacture of delicatessen foods,	300-500-750	0.60	80	22	150	—	—
72)	12.6	Inspection of glasses and bottles, product control, trimming, sorting, decoration	300-500-750	0.60	80	22	150	—	—
73)	12.7	Laboratories	300-500-750	0.60	80	19	150	75	50

Sl. No.	Ref. No.	Type of task/activity area	$\bar{E}_m$ ( $L_x$ )	$U_o$	$R_a$	$R_{UGL}$	$\bar{E}_{m,z}$ ( $L_x$ )	$\bar{E}_{m,wall}$ ( $L_x$ )	$\bar{E}_{m,ceiling}$ ( $L_x$ )
(1)	(2)	(3)	(4)	(5)	(6)	(7)	(8)	(9)	(10)
74)	12.8	Colour inspection	750-1000-1500	0.70	90	19	150	75	50
		<b>13 Industrial Activities and Crafts-Foundries and Metal Casting</b>							
75)	13.1	Man-size underfloor tunnels, cellars, etc.	30 -50- 75	0.40	70	—	—	—	—
76)	13.2	Platforms	75-100-150	0.40	70	25	50	—	—
77)	13.3	Sand preparation	150-200-300	0.40	80	25	50	—	—
78)	13.4	Dressing	150-200-300	0.40	80	25	50	—	—
79)	13.5	Work stations at cupola and mixer	150 -200-300	0.40	80	25	50	—	—
80)	13.6	Casting bay	150-200-300	0.40	80	25	50	—	—
81)	13.7	Shake out areas	150-200-300	0.40	80	25	50	—	—
82)	13.8	Machine moulding	150-200-300	0.40	80	25	50	—	—
83)	13.9	Hand and core moulding	200- 300-500	0.60	80	25	100	—	—
84)	13.10	Die casting	200- 300-500	0.60	80	25	100	—	—
85)	13.11	Model building	300-500-750	0.60	80	22	150	—	—
		<b>14 Industrial Activities and Crafts-Hairdressers</b>							
86)	14.1	Hairdressing	300-500-750	0.60	90	19	150	75	50
		<b>15 Industrial Activities and Crafts – Jewellery Manufacturing</b>							
87)	15.1	Working with precious stones	1000 -1500-2000	0.70	90	19	150	75	50
88)	15.2	Manufacture of jewellery	750-1000-1500	0.70	90	19	150	75	50
89)	15.3	Watch making (manual)	1000-1500-2000	0.70	80	19	150	75	50
90)	15.4	Watch making (automatic)	300-500-750	0.60	80	19	150	75	50
		<b>16 Industrial Activities and Crafts-Laundries and Dry Cleaning</b>							
91)	16.1	Goods in, marking and sorting	200-300-500	0.60	80	25	100	—	—
92)	16.2	Washing and dry cleaning		0.60	80	25	100	—	—

Sl. No.	Ref. No.	Type of task/activity area	$\bar{E}_m$ ( $L_x$ )	$U_o$	$R_a$	$R_{UGL}$	$\bar{E}_{m,z}$ ( $L_x$ )	$\bar{E}_{m,wall}$ ( $L_x$ )	$\bar{E}_{m,ceiling}$ ( $L_x$ )
(1)	(2)	(3)	(4)	(5)	(6)	(7)	(8)	(9)	(10)
			200-300-500						
93)	16.3	Ironing, pressing	200-300-500	0.60	80	25	100	—	—
94)	16.4	Inspection and repairs	500-750 – 1000	0.70	80	19	150	75	50
	<b>17</b>	<b>Industrial Activities and Crafts-Leather and Leather Goods</b>							
95)	17.1	Work on vats, barrels, pits	150-200-300	0.40	80	25	75	—	—
96)	17.2	Fleshing, skiving, rubbing, tumbling of skins	200-300-500	0.40	80	25	100	—	—
97)	17.3	Saddlery work, shoe manufacture: stitching, sewing, polishing, shaping, cutting, punching	300-500-750	0.60	80	22	150	—	—
98)	17.4	Sorting	300-500-750	0.60	90	22	150	—	—
99)	17.5	Leather dyeing (machine)	300-500-750	0.60	80	22	150	—	—
100)	17.6	Quality control	750-1000-1500	0.70	80	19	150	75	50
101)	17.7	Colour inspection	750-1000-1500	0.70	90	19	150	75	50
102)	17.8	Shoe making	300-500-750	0.60	80	22	150	—	—
103)	17.9	Glove making	300-500-750	0.60	80	22	150	—	—
	<b>18</b>	<b>Industrial Activities and Crafts-Metal Working and Processing</b>							
104)	18.1	Open die forging	150-200-300	0.60	80	25	50	—	—
105)	18.2	Drop forging	200-300-500	0.60	80	25	75	—	—
106)	18.3	Welding	200-300-500	0.60	80	25	75	—	—
107)	18.4	Rough and average machining: tolerances $\geq 0.1$ mm	200-300-500	0.60	80	22	75	—	—

Sl. No.	Ref. No.	Type of task/activity area	$\bar{E}_m$ ( $L_x$ )	$U_o$	$R_a$	$R_{UGL}$	$\bar{E}_{m,z}$ ( $L_x$ )	$\bar{E}_{m,wall}$ ( $L_x$ )	$\bar{E}_{m,ceiling}$ ( $L_x$ )
(1)	(2)	(3)	(4)	(5)	(6)	(7)	(8)	(9)	(10)
108)	18.5	Precision machining; grinding; tolerances < 0.1 mm	300-500-750	0.70	80	19	150	75	50
109)	18.6	Scribing; inspection	500-750-1000	0.70	80	19	150	75	50
110)	18.7	Wire and pipe drawing shops; cold forming	200-300-500	0.60	80	25	75	-	-
111)	18.8	Plate machining: thickness $\geq$ 5 mm	150-200-300	0.60	80	25	50	-	-
112)	18.9	Sheet metalwork: thickness < 5 mm	200-300-500	0.60	80	22	75	-	-
113)	18.10	Tool making; cutting equipment manufacture	500-750-1000	0.70	80	19	150	-	-
114)	18.11	Assembly:						-	-
115)		- Rough	150-200-300	0.60	60	25	50	-	-
116)		- Medium	200-300-500	0.60	80	25	75	-	-
117)		- Fine	300-500-750	0.60	80	22	150	-	-
118)		- Precision	500-750-1000	0.70	80	19	150	75	50
119)		Galvanizing	200-300-500	0.60	80	25	75	-	-
120)	18.12	Surface preparation and painting	500-750-1000	0.70	80	25	150	-	-
121)	18.13	Tool, template and jig making, precision mechanics, micro-mechanics	750-1000-1500	0.70	80	19	150	75	50
	<b>19</b>	<b>Industrial Activities and Crafts-Paper and Paper Goods</b>							
122)	19.1	Edge runners, pulp mills	150-200-300	0.40	80	25	50	-	-
123)	19.2	Paper manufacture and processing, paper and corrugating machines,	200-300-500	0.60	80	25	75	-	-

Sl. No.	Ref. No.	Type of task/activity area	$\bar{E}_m$ ( $L_x$ )	$U_o$	$R_a$	$R_{UGL}$	$\bar{E}_{m,z}$ ( $L_x$ )	$\bar{E}_{m,wall}$ ( $L_x$ )	$\bar{E}_{m,ceiling}$ ( $L_x$ )
(1)	(2)	(3)	(4)	(5)	(6)	(7)	(8)	(9)	(10)
124)	19.3	cardboard manufacture Standard bookbinding work, for example folding, sorting, gluing, cutting, embossing, sewing	300-500-750	0.60	80	22	150	—	—
<b>20 Industrial Activities and Crafts-Power Stations</b>									
125)	20.1	Fuel supply plant	30-50-75	0.40	70	—	—	—	—
126)	20.2	Boiler house	75-100-150	0.40	70	28	50	—	—
127)	20.3	Machine halls	150-200-300	0.40	80	25	50	—	—
128)	20.4	Side rooms, for example pump rooms, condenser rooms, etc; switchboards (inside buildings)	150-200-300	0.40	80	25	50	—	—
129)	20.5	Control rooms	300-500-750	0.70	80	19	150	75	50
<b>21 Industrial Activities and Crafts-Printers</b>									
130)	21.1	Cutting, gilding, embossing, block engraving, work on	300-500-750	0.60	80	19	150	75	50
131)	21.2	Paper sorting and hand printing	300-500-750	0.60	80	19	150	75	50
132)	21.3	Type setting, retouching, lithography	750-1000-1500	0.70	80	19	150	75	50
133)	21.4	Colour inspection in multicoloured printing	1000-1500-2000	0.70	90	19	150	75	50
134)	21.5	Steel and copper engraving	1500-2000-3000	0.70	80	19	150	75	50
<b>22 Industrial Activities and Crafts-Rolling Mills, Iron and Steel Works</b>									
135)	22.1	Production plants without manual operation	30-50-75	0.40	70	—	—	—	—
136)	22.2	Production plants with occasional manual operation	100-150-200	0.40	70	28	50	—	—

Sl. No.	Ref. No.	Type of task/activity area	$\bar{E}_m$ ( $L_x$ )	$U_o$	$R_a$	$R_{UGL}$	$\bar{E}_{m,z}$ ( $L_x$ )	$\bar{E}_{m,wall}$ ( $L_x$ )	$\bar{E}_{m,ceiling}$ ( $L_x$ )
(1)	(2)	(3)	(4)	(5)	(6)	(7)	(8)	(9)	(10)
137)	22.3	Production plants with continuous manual operation	150-200-300	0.60	80	25	50	—	—
138)	22.4	Slab Store	30-50-75	0.40	70	—	—	—	—
139)	22.8	Furnaces	150-200-300	0.40	70	25	50	—	—
140)	22.9	Mill train; coiler; shear line	200-300-500	0.60	70	25	75	—	—
141)	22.10	Control platforms; control panels	200-300-500	0.60	80	22	75	—	—
142)	22.11	Test, measurement and inspection	300-500-750	0.60	80	22	150	—	—
143)	22.12	Underfloor man-sized tunnels; belt sections, cellars, etc	30-50-75	0.40	70	—	—	—	—
<b>23</b>		<b>Industrial Activities and Crafts-Textile Manufacture and Processing</b>							
144)	23.1	Work stations and zones in baths, bale opening	150-200-300	0.60	70	25	50	—	—
145)	23.2	Carding, washing, ironing, devilling machine work, drawing, combing, sizing, card cutting, pre-spinning, jute and hemp spinning	200-300-500	0.60	70	22	100	—	—
146)	23.3	Spinning, plying, reeling, winding	300-500-750	0.60	70	22	150	—	—
147)	23.4	Warping, weaving, braiding, knitting	300-500-750	0.60	70	22	150	—	—
148)	23.5	Sewing, fine knitting, taking up stitches	500-750-1000	0.70	80	22	150	—	—
149)	23.6	Manual design, drawing patterns	500-750-1000	0.70	90	22	150	—	—
150)	23.7	Finishing, dyeing	300-500-750	0.60	80	22	150	—	—
151)	23.8	Drying room	75-100-150	0.40	60	28	50	—	—
152)	23.9	Automatic fabric printing	300-500-750	0.60	90	25	100	—	—



Sl. No.	Ref. No.	Type of task/activity area	$\bar{E}_m$ ( $L_x$ )	$U_o$	$R_a$	$R_{UGL}$	$\bar{E}_{m,z}$ ( $L_x$ )	$\bar{E}_{m,wall}$ ( $L_x$ )	$\bar{E}_{m,ceiling}$ ( $L_x$ )
(1)	(2)	(3)	(4)	(5)	(6)	(7)	(8)	(9)	(10)
153)	23.10	Burling, picking, trimming	750-1000 - 1500	0.70	80	19	150	75	50
154)	23.11	Colour inspection; fabric control	750-1000 - 1500	0.70	90	19	150	75	50
155)	23.12	Invisible mending	1250-1500 - 2000	0.70	90	19	150	75	50
156)	23.13	Hat manufacturing	300-500- 750	0.60	80	22	150	-	-
<b>24 Industrial Activities and Crafts-Vehicle Construction and Repair</b>									
157)	24.1	Press shop - large parts	200-300- 500	0.60	80	25	100	-	-
158)	24.2	Press shop - visual inspection	300-500- 750	0.60	80	22	150	-	-
159)	24.3	Body work and assembly-automatic line	200-300- 500	0.60	80	25	100	-	-
160)	24.4	Body work and assembly-manual welding	300-500- 750	0.60	80	22	150	-	-
161)	24.5	Painting, spraying chamber, polishing chamber	500-750- 1000	0.70	80	22	150	-	-
162)	24.6	Painting, inspection, touch-up and polishing	750-1000 - 1500	0.70	90	19	150	75	50
163)	24.7	Upholstery manufacture (manual) Detailing: Subparts assembly (doors, dashboard, upholstery)	750-1000 - 1500	0.70	80	19	150	75	50
164)	24.8	Underchassis assembly Motor and mechanical assembly Final assembly conveyor line	500-750- 1000	0.70	80	22	150	-	-
165)	24.9	Detailing - work with electronics	500-750- 1000	0.60	90	22	150	-	-
166)	24.10	Final inspection	750-1000 - 1500	0.70	90	19	150	75	50

Sl. No.	Ref. No.	Type of task/activity area	$\bar{E}_m$ ( $L_x$ )	$U_o$	$R_a$	$R_{UGL}$	$\bar{E}_{m,z}$ ( $L_x$ )	$\bar{E}_{m,wall}$ ( $L_x$ )	$\bar{E}_{m,ceiling}$ ( $L_x$ )
(1)	(2)	(3)	(4)	(5)	(6)	(7)	(8)	(9)	(10)
167)	24.11	General vehicle services, repair and testing	300-500-750	0.60	80	22	100	-	-
	<b>25</b>	<b>Industrial Activities and Crafts-Wood Working and Processing</b>							
168)	25.1	Automatic processing, for example drying, plywood manufacturing	30-50-75	0.40	70	28	-	-	-
169)	25.2	Steam pits	100-150 - 200	0,40	70	28	50	-	-
170)	25.3	Saw frame	200 -300-500	0.60	70	25	100	-	-
171)	25.4	Work at joiner's bench, gluing, assembly	200-300-500	0.60	80	25	100	-	-
172)	25.5	Polishing, painting, fancy joinery	500-750-1000	0.70	80	22	150	-	-
173)	25.6	Work on wood working machines, for example turning, fluting, dressing, rebating, grooving, cutting, sawing, sinking	300-500-750	0.60	80	19	150	75	50
174)	25.7	Selection of veneer woods	500-750-1000	0.90	70	22	150	-	-
175)	25.8	Marquetry, inlay work	500-750-1000	0.90	70	22	150	-	-
176)	25.9	Quality control, inspection	750-1000-1500	0.90	70	19	150	75	50
	<b>26</b>	<b>Offices</b>							
177)	26.1	Filing, copying, etc	200-300-500	0.40	80	19	100	75	50
		General office area							
178)	26.2	Writing, typing, reading, data processing	300-500-750	0.60	80	19	150	75	50
179)	26.3	Private Cabins	300-500-750	0.70	80	19	150	75	50
180)	26.4	CAD work stations	300-500-750	0.60	80	19	150	75	50

Sl. No.	Ref. No.	Type of task/activity area	$\bar{E}_m$ ( $L_x$ )	$U_o$	$R_a$	$R_{UGL}$	$\bar{E}_{m,z}$ ( $L_x$ )	$\bar{E}_{m,wall}$ ( $L_x$ )	$\bar{E}_{m,ceiling}$ ( $L_x$ )
(1)	(2)	(3)	(4)	(5)	(6)	(7)	(8)	(9)	(10)
181)	26.5	Huddle / Breakout Area	200-300-500	0.60	80	19	150	75	50
182)	26.6	Conference and meeting rooms	300-500-750	0.60	80	19	150	75	50
183)	26.7	Light on presenter	150-200-300		80	19			
184)	26.8	Reception desk	200-300-500	0.60	80	22	100	75	50
185)	26.9	Archiving	150-200-300	0.40	80	25	75	—	—
186)	26.10	Canteens and Break out areas	150-200-300	0.60	80	22	—	—	—
187)	26.11	Resting rooms	75-100-200	0.40	80	22	—	—	—
188)	26.12	Rooms for Physical exercise	200-300-500	0.40	80	22	—	—	—
189)	26.13	Cloakroom (area), wash room	150- 200-300	0.40	80	25	100	75	50
190)	26.14	Facial Lighting in front of mirrors	200-300-500	0.40	80	—	—	—	—
191)	26.15	Sick bay	300-500-750	0.60	80	19	100	75	50
192)	26.16	Rooms for medical attention	300-500-750	0.40	90	19	100	75	50
193)	26.17	General cleaning	75-100-150	0.40	80	—	—	—	—
194)	26.18	Corridors and circulation areas	75 -100-150	0.40	70	28	—	—	—
195)	26.19	Stairs, escalators, travelators	75-100-150	0.40	70	25	—	—	—
196)	26.20	Lifts	75-100-150	0.40	70	25	—	—	—
197)	26.21	Area in front of lifts and escalators	150-200-300	0.40	70	25	—	75	50
198)	26.22	Auditorium, training hall, town hall, amphitheater	300-500-750	0.60	80	19	75	50	—
	<b>27</b>	<b>Retail Premises</b>							
199)	27.1	General sales area	200-300-500	0.40	80	22	75	—	—
200)	27.2	Till area	300-500-750	0.60	80	19	100	75	50
201)	27.3	Wrapper table	300-500-750	0.60	80	22	100	—	—
202)	27.4	Storage area	200-300-500	0.40	80	25	50	—	—

Sl. No.	Ref. No.	Type of task/activity area	$\bar{E}_m$ ( $L_x$ )	$U_o$	$R_a$	$R_{UGL}$	$\bar{E}_{m,z}$ ( $l_x$ )	$\bar{E}_{m,wall}$ ( $l_x$ )	$\bar{E}_{m,ceiling}$ ( $l_x$ )
(1)	(2)	(3)	(4)	(5)	(6)	(7)	(8)	(9)	(10)
203)	27.5	Dressing/fitting room	200-300-500	0.4	90	—	—	—	—
		<b>28</b>	<b>Places of Public Assembly General Areas</b>						
204)	28.1	Entrance halls	75-100-150	0.40	80	22	50	—	—
205)	28.2	Cloakrooms	150-200-300	0.40	80	25	75	—	—
206)	28.3	Lounges	150-200-300	0.40	80	22	75	—	—
207)	28.4	Ticket offices	200-300-500	0.60	80	22	75	—	—
		<b>29</b>	<b>Places of Public Assembly- Restaurants and Hotels</b>						
208)	29.1	Reception/cashier desk, porters desk	200-300-500	0.60	80	22	100	—	—
209)	29.2	Kitchen	300-500-750	0.60	80	22	100	—	—
210)	29.3	Restaurant, dining room, function room	—	—	80	—	—	—	—
211)	29.4	Self-service restaurant	150-200-300	0.40	80	22	75	—	—
212)	29.5	Buffet	200-300-500	0.60	80	22	75	—	—
213)	29.6	Conference rooms	300-500-750	0.60	80	19	150	75	50
214)	29.7	Corridors	75-100-150	0.40	80	25	50	—	—
		<b>30</b>	<b>Places of Public Assembly-Theatres, Concert Halls, Cinemas, Places for Entertainment</b>						
215)	30.1	Practice rooms	200-300-500	0.60	80	22	100	—	—
216)	30.2	Dressing rooms	200-300-500	0.60	90	22	100	—	—
217)	30.3	Seating areas-maintenance, cleaning	150-200-300	0.40	80	22	50	—	—
218)	30.4	Stage area rigging	200-300-500	0.40	80	25	75	—	—
		<b>31</b>	<b>Places of Public Assembly-Trade Fairs, Exhibition Halls</b>						
219)	31.1	General lighting	200-300-500	0.40	80	22	50	—	—
		<b>32</b>	<b>Places of Public Assembly-Museums</b>						

Sl. No.	Ref. No.	Type of task/activity area	$\bar{E}_m$ ( $L_x$ )	$U_o$	$R_a$	$R_{UGL}$	$\bar{E}_{m,z}$ ( $L_x$ )	$\bar{E}_{m,wall}$ ( $L_x$ )	$\bar{E}_{m,ceiling}$ ( $L_x$ )
(1)	(2)	(3)	(4)	(5)	(6)	(7)	(8)	(9)	(10)
220)	32.1	Exhibits, insensitive to light	—	—	80	—	—	—	—
221)	32.2	Exhibits sensitive to light	—	—	80	—	—	—	—
<b>33 Places of Public Assembly-Libraries</b>									
222)	33.1	Bookshelves	150 -200-300	0.40	80	19	—	—	—
223)	33.2	Reading area	300-500-750	0.60	80	19	100	75	50
224)	33.3	Counters	300-500-750	0.60	80	19	150	75	50
225)	33.4	General lighting	200-300-500	0.40	80	22	75	—	—
<b>34 Places of Public Assembly-Car Parks (Indoor)</b>									
226)	34.1	Entry/exit ramps (during daylight hours)	200-300-500	0.40	70	25	75	—	—
227)	34.2	Entry/exit ramps (at night)	50-75-100	0.40	70	25	50	—	—
228)	34.3	Traffic lanes, internal ramps and pedestrian paths	50-75-100	0.40	70	25	50	—	—
229)	34.4	Parking areas - not open to public	50-75-100	0.25	70	—	50	—	—
230)	34.5	Parking areas - open to public with a large number of users e.g shopping centers, arenas.	100-150-200	0.40	70	—	50	—	—
231)	34.6	Ticket office	200-300-500	0.60	80	19	75	75	50
<b>35 Educational Premises-Nursery School, Play School</b>									
232)	35.1	Play room	200-300-500	0.40	80	22	100	75	50
233)	35.2	Nursery	200-300-500	0.40	80	22	100	75	50
234)	35.3	Handicraft room	200-300-500	0.60	80	19	100	75	50
<b>36 Educational Premises-Educational Buildings</b>									
235)	36.1	Classroom-General activities	300-500-750	0.60	80	19	150	75	50

Sl. No.	Ref. No.	Type of task/activity area	$\bar{E}_m$ ( $L_x$ )	$U_o$	$R_a$	$R_{UGL}$	$\bar{E}_{m,z}$ ( $L_x$ )	$\bar{E}_{m,wall}$ ( $L_x$ )	$\bar{E}_{m,ceiling}$ ( $L_x$ )
(1)	(2)	(3)	(4)	(5)	(6)	(7)	(8)	(9)	(10)
236)	36.2	Auditorium, lecture halls	300-500-750	0.60	80	19	150	75	50
237)	36.3	Attending lecture in seating areas in auditoriums and lecture halls	150-200-300	0.60	80	19	75	75	50
238)	36.4	Black, green and white boards	300-500-750	0.70	80	19	—	—	—
239)	36.5	Black, green and white boards in auditorium and lecture halls	300-500-750	0.60	80	19	—	—	—
240)	36.6	Projector and smartboard presentation	—	—	—	—	—	—	—
241)	36.7	Display board	150-200-300	0.60	80	19	—	—	—
242)	36.8	Demonstration table in auditoriums and lecture halls	500-750-1000	0.70	80	19	—	—	—
243)	36.9	Light on teacher / presenter	—	—	80	—	150	—	—
244)	36.10	Light on podium area	200-300-500	0.70	80	—	—	—	—
245)	36.11	Computer work only	200-300-500	0.60	80	19	100	75	50
246)	36.12	Art rooms in art schools	500-750-1000	0.70	90	19	150	75	50
247)	36.13	Technical drawing rooms	500-750-1000	0.60	80	19	150	75	50
248)	36.14	Practical rooms and laboratories	300-500-750	0.60	80	19	150	75	50
249)	36.15	Handcraft rooms	300-500-750	0.60	80	19	150	75	50
250)	36.16	Teaching workshop	300-500-750	0.60	80	19	150	75	50
251)	36.17	Preparation rooms and workshops	300-500-750	0.60	80	22	150	—	—
252)	36.18	Entrance halls	150-200-300	0.40	80	22	75	—	—
253)	36.19	Circulation areas, corridors	75-100-150	0.40	80	25	50	—	—

Sl. No.	Ref. No.	Type of task/activity area	$\bar{E}_m$ ( $L_x$ )	$U_o$	$R_a$	$R_{UGL}$	$\bar{E}_{m,z}$ ( $L_x$ )	$\bar{E}_{m,wall}$ ( $L_x$ )	$\bar{E}_{m,ceiling}$ ( $L_x$ )
(1)	(2)	(3)	(4)	(5)	(6)	(7)	(8)	(9)	(10)
254)	36.20	Stairs	100-150-200	0.40	80	25	50	—	—
255)	36.21	Student common rooms and assembly halls	150-200-300	0.40	80	22	75	—	—
256)	36.22	Teachers rooms	200-300-500	0.60	80	19	100	75	50
257)	36.23	Library - Bookshelves	150-200-300	0.60	80	19	75	75	50
258)	36.24	Library - Reading areas	300-500-750	0.60	80	19	100	75	50
259)	36.25	Stock rooms for teaching materials	75 – 100-150	0.40	80	25	50	—	—
260)	36.26	Sports halls, gymnasiums, swimming pools	200 – 300 – 500	0.60	80	22	100	—	—
261)	36.27	School canteens	150-200-300	0.40	80	22	75	—	—
262)	36.28	Kitchen	300 – 500-750	0.60	80	22	100	—	—
<b>37 Health Care Premises-Rooms for General Use</b>									
263)	37.1	Waiting rooms	150-200-300	0.40	80	22	75	75	30
264)	37.2	Corridors - during the day	75-100-150	0.40	80	22	50	50	30
265)	37.3	Corridors: cleaning	75-100-150	0.40	80	22	50	50	30
266)	37.4	Corridors: during the night	30-50-75	0.40	80	22	—	—	—
267)	37.5	Corridors with multi- purpose use (for example pre examination of patients)	150-200-300	0.60	80	22	75	75	50
268)	37.6	Day rooms	200-300-500	0.60	80	22	75	75	50
269)	37.7	Lifts for persons and visitors	75- 100-150	0.60	80	22	50	50	30
270)	37.8	Service lifts	150-200-300	0.60	80	22	75	75	50
<b>38 Health Care Premises-Staff Rooms</b>									
271)	38.1	Staff office	300-500-750	0.60	80	19	150	75	50

Sl. No.	Ref. No.	Type of task/activity area	$\bar{E}_m$ ( $L_x$ )	$U_o$	$R_a$	$R_{UGL}$	$\bar{E}_{m,z}$ ( $L_x$ )	$\bar{E}_{m,wall}$ ( $L_x$ )	$\bar{E}_{m,ceiling}$ ( $L_x$ )
(1)	(2)	(3)	(4)	(5)	(6)	(7)	(8)	(9)	(10)
272)	38.2	Staff rooms	200-300-500	0.60	80	19	100	75	50
<b>39 Health Care Premises-Wards, Maternity Wards</b>									
273)	39.1	General lighting	75-100-150	0.70	80	19	50	50	30
274)	39.2	Reading lighting	200-300-500	0.70	80	19	100	75	50
275)	39.3	Wards-Simple examinations	200-300-500	0.70	80	19	100	75	50
276)	39.4	Examination and treatment	750-1000-1500	0.70	90	19	150	75	50
277)	39.5	Night lighting, observation lighting	5	—	80	—	—	—	—
278)	39.6	Bathrooms and toilets for patients	150-200-300	0.70	90	22	75	75	50
<b>40 Health Care Premises-Examination Rooms (General)</b>									
279)	40.1	General lighting	300-500-750	0.60	90	19	150	75	50
280)	40.2	Examination and treatment	750-1000-1500	0.70	90	19	150	75	50
<b>41 Health Care Premises-Eye Examination Rooms</b>									
281)	41.1	General lighting	300-500-750	0.60	90	19	150	75	50
282)	41.2	Examination of the outer eye	750-1000-1500	—	90	—	150	75	50
283)	41.3	Reading and colour vision tests with vision charts	300-500-750	0.70	90	19	150	75	50
<b>42 Health Care Premises-Ear Examination Rooms</b>									
284)	42.1	General lighting	300-500-750	0.60	90	19	150	75	50
285)	42.2	Ear examination	750-1000-1500	—	90	—	150	75	50
<b>43 Health Care Premises-Scanner Rooms</b>									
286)	43.1	General lighting	200-300-500	0.60	80	19	100	75	50
287)	43.2	Scanners with image enhancers and television systems	30-50-75	—	80	19	—	—	—



Sl. No.	Ref. No.	Type of task/activity area	$\bar{E}_m$ ( $L_x$ )	$U_o$	$R_a$	$R_{UGL}$	$\bar{E}_{m,z}$ ( $L_x$ )	$\bar{E}_{m,wall}$ ( $L_x$ )	$\bar{E}_{m,ceiling}$ ( $L_x$ )
(1)	(2)	(3)	(4)	(5)	(6)	(7)	(8)	(9)	(10)
<b>44 Health Care Premises-Delivery Rooms</b>									
288)	44.1	General lighting	200-300-500	0.60	90	19	100	75	50
289)	44.2	Examination and treatment	750-1000-1500	0.70	90	19	150	75	50
<b>45 Health Care Premises-Treatment Rooms (General)</b>									
290)	45.1	Dialysis	300-500-750	0.60	80	19	150	75	50
291)	45.2	Dermatology	300-500-750	0.60	90	19	150	75	50
292)	45.3	Endoscopy	200-300-500	0.60	80	19	100	75	50
293)	45.4	Plastering	300-500-750	0.60	80	19	150	75	50
294)	45.5	Medical baths	200-300-500	0.60	80	19	100	75	50
295)	45.6	Massage and radiotherapy	200-300-500	0.60	80	19	100	75	50
<b>46 Health Care Premises-Operating Areas</b>									
296)	46.1	Pre-op and recovery rooms	500-750-1000	0.60	90	19	150	75	50
297)	46.2	Operating cavity surround	750- 1000-1500	0.60	90	19	150	75	50
298)	46.3	Operating theatre	750-100 -1500	0.60	90	19	—	—	—
299)	46.4	Operating cavity	—	—	90	—	—	—	—
<b>47 Health Care Premises-Intensive Care Unit</b>									
300)	47.1	General lighting	200-300-500	0.60	90	19	50	50	30
301)	47.2	Simple examinations	300-500-750	0.60	90	19	100	75	50
302)	47.3	Examination and treatment	1000-1250 -1500	0.70	90	19	150	75	50
303)	47.4	Night watch	20	—	90	19	—	—	—
<b>48 Health Care Premises-Dentists</b>									
304)	48.1	General lighting	300-500-750	0.60	90	19	150	75	50
305)	48.2	At the patient	750-1000-1500	0.70	90	—	150	75	50
306)	48.3	Operating cavity	—	—	—	—	—	—	—

Sl. No.	Ref. No.	Type of task/activity area	$\bar{E}_m$ ( $L_x$ )	$U_o$	$R_a$	$R_{UGL}$	$\bar{E}_{m,z}$ ( $L_x$ )	$\bar{E}_{m,wall}$ ( $L_x$ )	$\bar{E}_{m,ceiling}$ ( $L_x$ )
(1)	(2)	(3)	(4)	(5)	(6)	(7)	(8)	(9)	(10)
307)	48.4	White teeth matching	—	—	—	—	—	—	—
	<b>49</b>	<b>Health Care Premises-Laboratories and Pharmacies</b>							
308)	49.1	General lighting	300-500-750	0.60	80	19	150	75	50
309)	49.2	Colour inspection	750-1000-1500	0.70	90	19	150	75	50
	<b>50</b>	<b>Health Care Premises-Decontamination Rooms</b>							
310)	50.1	Sterilization	300-500-750	0.60	80	22	100	75	50
311)	50.2	Disinfection	300-500-750	0.60	80	22	100	75	50
	<b>51</b>	<b>Health Care Premises-Autopsy Rooms and Mortuaries</b>							
312)	51.1	General lighting	300-500-750	0.60	90	19	150	75	50
313)	51.2	Autopsy table and dissecting table	500 -7500	0.70	90	—	150	75	50
	<b>52</b>	<b>Transportation Areas-Airports</b>							
314)	52.1	Arrival and departure halls, baggage claim areas	150-200-300	0.40	80	22	75	—	—
315)	52.2	Connecting areas	100-150-200	0.40	80	22	50	—	—
316)	52.3	Information desks, check-in desks	300-500-750	0.70	80	19	150	—	—
317)	52.4	Customs and passport control desks	300-500-750	0.70	80	19	150	—	—
318)	52.5	Waiting areas	150-200-300	0.40	80	22	50	—	—
319)	52.6	Luggage storage rooms	150-200-300	0.40	80	25	50	—	—
320)	52.7	Security check areas	200-300-500	0.60	80	19	100	—	—
321)	52.8	Air traffic control tower	300-500-750	0.60	80	19	50	75	50
322)	52.9	Tasks in hangars: Testing and repair areas engine test areas measuring areas	300-500-750	0.60	80	22	50	—	—

Sl. No.	Ref. No.	Type of task/activity area	$\bar{E}_m$ ( $L_x$ )	$U_o$	$R_a$	$R_{UGL}$	$\bar{E}_{m,z}$ ( $L_x$ )	$\bar{E}_{m,wall}$ ( $L_x$ )	$\bar{E}_{m,ceiling}$ ( $L_x$ )
(1)	(2)	(3)	(4)	(5)	(6)	(7)	(8)	(9)	(10)
	<b>53</b>	<b>Transportation Areas-Railway Installations</b>							
323)	53.1	Fully enclosed platforms, small number of passengers	30-50-75	0.30	80	—	—	—	—
324)	53.2	Fully enclosed platforms, medium number of passengers	75-100-150	0.40	80	—	—	—	—
325)	53.3	Fully enclosed platforms, large number of passengers	150-200-300	0.50	80	—	—	—	—
326)	53.4	Fully enclosed passenger subways (underpasses), small number of passengers	30-50-75	0.30	80	—	—	—	—
327)	53.5	Fully enclosed passenger subways (underpasses), medium number of passengers	75-100-150	0.40	80	—	—	—	—
328)	53.6	Fully enclosed passenger subways (underpasses), large number of passengers	150-200-300	0.50	80	—	—	—	—
329)	53.7	Stairs, escalators, small number of passengers	30-50-75	0.30	80	—	—	—	—
330)	53.8	Stairs, escalators, medium number of passengers	75-100-150	0.40	80	—	—	—	—
331)	53.9	Stairs, escalators, large number of passengers	150-200-300	0.50	80	—	—	—	—
332)	53.10	Ticket hall and concourse	150-200-300	0.50	80	28	75	—	—

Sl. No.	Ref. No.	Type of task/activity area	$\bar{E}_m$ ( $L_x$ )	$U_o$	$R_a$	$R_{UGL}$	$\bar{E}_{m,z}$ ( $L_x$ )	$\bar{E}_{m,wall}$ ( $L_x$ )	$\bar{E}_{m,ceiling}$ ( $L_x$ )
(1)	(2)	(3)	(4)	(5)	(6)	(7)	(8)	(9)	(10)
333)	53.11	Ticket counters and luggage offices	200-300-500	0.50	80	19	100	75	50
334)	53.12	Waiting rooms	150-200-300	0.40	80	22	75	—	—
335)	53.13	Entrance halls, station halls	150-200-300	0.40	80	—	75	—	—
336)	53.14	Switch and plant rooms	150-200-300	0.50	80	28	50	—	—
337)	53.15	Railway control centre (area of dispatcher)	150-200-300	0.50	80	19	—	—	—
338)	53.16	Access tunnels	30-50-75	0.40	20	—	—	—	—
339)	53.17	Assembly work in maintenance sheds - rough	150-200-300	0.40	80	—	—	—	—
340)	53.18	Assembly work in maintenance sheds - medium	200-300-500	0.50	80	—	—	—	—
341)	53.19	Assembly work in maintenance sheds - fine	300-500 - 750	0.60	80	—	—	—	—
342)	53.20	Assembly work in maintenance sheds precision	500-750-1000	0.70	80	—	—	—	—
343)	53.21	Circulation areas for maintenance halls for railway vehicles (without additional vehicular traffic)	75-100-150	0.25	80	—	—	—	—
344)	53.22	Circulation areas for maintenance halls for railway vehicles (with additional vehicular traffic)	100-150-200	0.40	80	—	—	—	—

## NOTES

- 1 For 33.1, Illuminance level mentioned here is vertical at bookshelves.
- 2 For 36.4, 36.7 and 36.23, Vertical Illuminance.
- 3 For 40.1 & 40.2, Preferred Color temperature should be 4 000 K to 5 000 K.

Sl. No.	Ref. No.	Type of task/activity area	$\bar{E}_m (L_x)$	$U_o$	$R_a$	$R_{UGL}$	$\bar{E}_{m,z} l_x$	$\bar{E}_{m,wall} l_x$	$\bar{E}_{m,ceiling} l_x$
(1)	(2)	(3)	(4)	(5)	(6)	(7)	(8)	(9)	(10)
	4	For 41.1, preferred Color temperature should be 4 000 K to 5 000 K.							
	5	For 41.2 and 41.3, preferred Color temperature should be 4 000 K to 6 500 K.							
	6	For 46.1, 46.2, 46.3 and 46.4, additional local lighting to be provided to achieve 10 000 Lux to 50 000 Lux.							

**4.1.8 Colour Rendering**

The colour appearance of light and its colour rendering capability are different aspects of the light sources. A faithful reproduction of an object colour depends on the colour rendering capability of the light source. In 1965, International Commission on Illumination (CIE) developed a quantitative method of assignment of colour rendering property and is denoted as Colour Rendering Index (CRI).

CRI is arrived at by a test by which a number of specified samples are tested under a standard or reference light source and the chromaticity coordinate are plotted on the IE triangle as given in Fig. 7 of Part 2 ‘Physics of Light: Section 3 Colour’ of National Lighting Code 2010. The same test is repeated under the source under test and corresponding chromaticity coordinate are plotted on the same plot. The difference between the position of each sample for test and standard source is measured to scale. The general colour rendering index (Ra) is obtained by the average value for eight samples (see Fig. 8 of Part 2 ‘Physics of Light Section 3 ‘Colour’ of National Lighting Code 2010). For perfect agreement of colour, the R1 value should be 100. In general:

$$Ra = 1/ (R1 + R2 + R3 + R4 + .....+ R8)$$

The specific colour rendering index for an individual sample is given by

$$Ri = 100 - 4.6\Delta Ei,$$

where,

$\Delta Ei$  = Chromaticity shift on the CIE chromaticity diagram for each sample.

From the obtained value of Ra, as calculated above, the colour rendering shall be evaluated as mentioned in the following table:

Colour Rendering Evaluated	Ra (General Colour Rendering Index)
Excellent	90 ≤ Ra < 100
Good	80 ≤ Ra < 90
Moderate	70 ≤ Ra < 80

**4.1.9** For detailed information regarding principles of good lighting, reference may be made to good practice [8-1(2)].

## 4.2 Daylighting

While the primary source of lighting for daylighting is the sun, the light received on earth's surface consists of two parts, namely, direct solar illuminance and sky illuminance. For effective daylighting design, direct solar illuminance shall not be considered due to the risk of glare and overheating. Glare from direct sun in occupied areas shall be addressed through window placement and shading design implying low to negligible reliance on direct solar illuminance for good daylighting. Instead, only sky illuminance shall be accounted for in contributing to the natural illumination of building interiors during daylight hours. This approach ensures a more balanced, diffused light that enhances occupant comfort and minimizes energy consumption.

**4.2.1** The relative amount of sky illuminance at a given point-in-time depends on the position of the sun defined by its altitude, which in turn, varies with the latitude of the locality, the day of the year and the time of the day, as indicated in Table 6.

**4.2.2** The external available horizontal sky illuminance (diffuse illuminance) values which are exceeded for about 90 percent of the daytime working hours may be taken as outdoor design illuminance values for ensuring adequacy of daylighting design. The outdoor design sky illuminance varies for different climatic regions of the country. The recommended design sky illuminance values are 6 800 lux for cold climate, 8 000 lux for composite climate, 9 000 lux for warm humid climate, 9 000 lux for temperate climate and 10 500 for hot-dry climate. For integration with the artificial lighting during daytime working hours an increase of 500 lux in the recommended sky design illuminance for daylighting is suggested.

**4.2.3** The daylight factor is dependent on the sky luminance distribution, which varies with atmospheric conditions. A clear design sky with its non-uniform distribution of luminance is adopted for the purposes of design in this Section.

### 4.2.4 Components of Daylight Factor

Daylight factor is the sum of all the daylight reaching on an indoor reference point from the following sources:

- a) Direct sky visible from the point,
- b) External surfaces reflecting light directly (see Note 1) to the point, and
- c) Internal surfaces reflecting and inter-reflecting light to the point.

#### NOTES

- 1 External surface reflection may be computed approximately only for points at the centre of the room, and for detailed analysis procedures are complicated and these may be ignored for actual calculations.
- 2 Each of the three components, when expressed as a ratio or percent of the simultaneous external illuminance on the horizontal plane, defines respectively the sky component (SC), the external reflected component (ERC) and the internal reflected component (IRC) of the daylight factor.

**4.2.4.1** The daylight factors on the horizontal plane only are usually taken, as the working plane in a room is generally horizontal; however, the factors in vertical planes should also be

considered when specifying daylighting values for special cases, such as daylighting on classrooms, blackboards, pictures and paintings hung on walls.

#### **4.2.5 Sky Component (SC)**

Sky component for a window of any size is computed by the use of the appropriate table of Annex B.

- a) The recommended sky component level should be ensured generally on the working plane at the following positions:
  - 1) At a distance of 3 m to 3.75 m from the window along the central line perpendicular to the window,
  - 2) At the centre of the room if more appropriate, and
  - 3) At fixed locations, such as school desks, black-boards and office tables.
- b) The daylight area of the prescribed sky component should not normally be less than half the total area of the room.

**4.2.5.1** The values obtainable from the tables are for rectangular, open unglazed windows, with no external obstructions. The values shall be corrected for the presence of window bars, glazing and external obstructions, if any. This assumes the maintenance of a regular cleaning schedule.

#### **4.2.5.2 Corrections for window bars**

The corrections for window bars shall be made by multiplying the values read from tables in Annex B by a factor equal to the ratio of the clear opening to the overall opening.

**Table 6 Solar Altitudes (to the Nearest Degree) for Indian Latitudes**  
(Clause 4.2.1)

Period of Year	22 June						21 March and 23 September						22 December					
	07 00	08 00	09 00	10 00	11 00	12 00	07 00	08 00	09 00	10 00	11 00	12 00	07 00	08 00	09 00	10 00	11 00	12 00
Hours of Day (Sun or Solar)																		
Latitude	17 00	16 00	15 00	14 00	13 00	--	17 00	16 00	15 00	14 00	13 00	--	17 00	16 00	15 00	14 00	13 00	--
(1)	(2)	(3)	(4)	(5)	(6)	(7)	(8)	(9)	(10)	(11)	(12)	(13)	(14)	(15)	(16)	(17)	(18)	(19)
10°N	18	31	45	58	70	77	15	30	44	59	72	80	9	23	35	46	53	57
13°N	19	32	46	60	72	80	15	29	44	58	70	77	8	21	33	43	51	54
16°N	20	33	47	61	74	83	14	29	43	56	68	74	7	19	31	41	48	51
19°N	21	34	48	62	75	86	14	28	42	55	66	71	5	18	29	48	45	48
22°N	22	35	49	62	75	89	14	28	41	53	64	68	4	16	27	36	42	45
25°N	23	36	49	63	76	88	13	27	40	52	61	65	3	14	25	34	39	42
28°N	23	36	49	63	76	86	13	26	39	50	59	62	1	13	23	31	37	39
31°N	24	37	50	62	75	82	13	25	37	48	56	56	-	11	21	28	34	36
34°N	25	37	49	62	73	79	12	25	36	46	53	56	-	9	18	26	31	33



**4.2.5.3 Correction for glazing**

Where windows are glazed, the sky components obtained from Annex A shall be reduced by 10 to 20 percent, provided the panes are of clear and clean glass. Where glass is of the frosted (ground) type, the sky components read from Annex A may be reduced by 15 to 30 percent. In case of tinted or reflective glass the reduction is about 50 percent. Higher indicated correction corresponds to larger windows and/or near reference points. In the case of openings and glazings which are not vertical, suitable correction shall be taken into account.

**4.2.5.4 Correction for external obstructions**

There is no separate correction, except that the values from tables in Annex B shall be read only for the unobstructed portions of the window.

**4.2.6 External Reflected Component (ERC)**

The value of the sky component corresponding to the portion of the window obstructed by the external obstructions may be found by the use of methods described in Annex C of good practice [8-1(3)].

These values when multiplied by the correction factors, corresponding to the mean elevation of obstruction from the point in question as given in Table 7, can be taken as the external reflected components for that point.

**Table 7 Correction Factor for ERC**  
(Clause 4.2.6)

<b>SI No.</b>	<b>Mean Angle of Elevation</b>	<b>Correction Factor</b>
(1)	(2)	(3)
i)	5°	0.086
ii)	15°	0.086
iii)	25°	0.142
iv)	35°	0.192
v)	45°	0.226
vi)	55°	0.274
vii)	65°	0.304
viii)	75°	0.324
ix)	85°	0.334

**4.2.6.1-**For method of calculating ERC, reference may be made to accepted standard {see Examples 10 and 11 given in Annex B of good practice [8-1(3)]}.

**4.2.7 Internal Reflected Component (IRC)**

The component of daylight factor contributed by reflection from the inside surfaces varies directly as the window area and inversely as the total area of internal surfaces, and depends on the reflection factor of the floor, wall and roof surfaces inside and of

the ground outside. For rooms white-washed on walls and ceiling and windows of normal sizes, the IRC will have sizeable value even at points far away from the window. External obstructions, when present, will proportionately reduce IRC. Where accurate values of IRC are desired, the same may be done in accordance with the good practice [8-1(3)].

#### **4.2.8 General Principles of Openings to Afford Good Lighting**

**4.2.8.1** Generally, while taller openings give greater penetrations, broader openings give better distribution of light. It is preferable that some area of the sky at an altitude of 20° to 25° should light up the working plane.

**4.2.8.2** Broader openings may also be equally or more efficient, provided their sills are raised by 300 mm to 600 mm above the working plane.

NOTE – It is to be noted that while placing window with a high sill level might help natural lighting, this is likely to reduce ventilation at work levels. While designing the opening for ventilation also, a compromise may be made by providing the sill level about 150 mm below the head level of workers.

**4.2.8.3** For a given penetration, a number of small openings properly positioned along the same, adjacent or opposite walls will give better distribution of illumination than a single large opening. The sky component at any point, due to a number of openings may be easily determined from the corresponding sky component contour charts appropriately superposed. The sum of the individual sky component for each opening at the point gives the overall component due to all the openings. The same charts may also facilitate easy drawing of sky component contours due to multiple openings.

**4.2.8.4** Unilateral lighting from side openings will, in general, be unsatisfactory if the effective width of the room is more than 2 to 2.5 times the distance from the floor to the top of the opening. In such cases provision of light shelves is always advantageous.

**4.2.8.5** Openings on two opposite sides will give greater uniformity of internal daylight illumination, especially when the room is 7 m or more across. They also minimize glare by illuminating the wall surrounding each of the opposing openings. Side openings on one side and clerestory openings on the opposite side may be provided where the situation so requires.

**4.2.8.6** Cross-lighting with openings on adjacent walls tends to increase the diffused lighting within a room.

**4.2.8.7** Openings in deep reveals tend to minimize glare effects.

**4.2.8.8** Openings shall be provided with *Chajjahs*, louvers, baffles or other shading devices to exclude, as far as possible, direct sunlight entering the room. *Chajjahs*, louvers, etc, reduce the effective height of the opening for which due allowance shall be made. Broad and low openings are, in general, much easier to shade against sunlight entry. Direct sunlight, when it enters, increases the inside illuminance very

considerably. Glare will result if it falls on walls at low angles, more so than when it falls on floors, especially when the floors are dark coloured or less reflective.

**4.2.8.9** Light control media, such as translucent glass panes (opal or matt) surfaced by grinding, etching or sandblasting, configured or corrugated glass, certain types of prismatic glass, tinted glass and glass blasts are often used. They should be provided, either fixed or movable outside or inside, especially in the upper portions of the openings. The lower portions are usually left clear to afford desirable view. The chief purpose of such fixtures is to reflect part of the light on to the roof and thereby increase the diffuse lighting within, light up the farther areas in the room and thereby produce a more uniform illumination throughout. They will also prevent the opening causing serious glare discomfort to the occupants but will provide some glare when illuminated by direct sunlight.

#### **4.2.9 Availability of Daylight in Multistoreyed Block**

Proper planning and layout of building can add appreciably to daylighting illumination inside. Certain dispositions of building masses offer much less mutual obstruction to daylight than others and have a significant relevance, especially when intensive site planning is undertaken. As guidance, the relative availability of daylight in multi-storeyed blocks (up to 4 storeys) of different relative orientations may be taken as given in Table 8.

**Table 8 Relative Availability of Daylight on the Window Plane at Ground Level in a Four-Storeyed Building Blocks (Clear Design-Sky as Basis, Daylight Availability Taken as Unity on an Unobstructed Façade, Values are for the Centre of the Blocks)**  
(Clause 4.2.9)

SI No.	Distance of Separation Between Blocks	Infinitely Long Parallel Blocks	Parallel Blocks Facing Each Other (Length = 2 x Height)	Parallel Blocks facing Gaps Between Opposite Blocks (Length = 2 x Height)
(1)	(2)	(3)	(4)	(5)
i)	0.5 Ht	0.15	0.15	0.25
ii)	1.0 Ht	0.30	0.32	0.38
iii)	1.5 Ht	0.40	0.50	0.55
iv)	2.0 Ht	0.50	0.60	0.68

**4.2.10** For specified requirements for daylighting of special occupancies and areas, reference may be made to good practice [8-1(4)]. For using annual climate-based daylight assessment of design can be referred from special publication. It also presents a computer simulation-based approach for assessment of adequacy of daylight in indoor spaces.

**NOTE** – Special publication may be Chapter 5 of Energy Conservation and Sustainable Building Code 2024.

### 4.3 Artificial Lighting

#### 4.3.1 Artificial lighting may have to be provided,

- a) where the recommended illumination levels have to be obtained by artificial lighting only;
- b) to supplement daylighting when the level of illumination falls below the recommended value; and
- c) where visual task may demand a higher level of illumination.

#### 4.3.2 Artificial Lighting Design for Interiors

For general lighting purposes, the recommended practice is to design for a level of illumination on the working plane on the basis of the recommended levels for visual tasks given in Table 5 by a method called 'Lumen method'. In order to make the necessary detailed calculations concerning the type and quantity of lighting equipment necessary, advance information on the surface reflectances of walls, ceilings and floors is required. Similarly, calculations concerning the brightness ratio in the interior call for details of the interior décor and furnishing. Stepwise guidance regarding designing the interior lighting systems for a building using the 'Lumen method' is given in 4.3.2.1 to 4.3.2.4.

##### 4.3.2.1 Determination of the illumination level

Recommended value of illumination shall be taken from Table 5, depending upon the type of work to be carried out in the location in question and the visual tasks involved.

##### 4.3.2.2 Selection of the light sources and luminaires

The selection of light sources and luminaires depends on the choice of lighting system, namely, general lighting, directional lighting and localized or local lighting.

##### 4.3.2.3 Determination of the luminous flux

- a) The luminous flux ( $\Phi$ ) reaching the working plane depends upon the following:
  - 1) Lumen output of the lamps,
  - 2) Type of luminaire,
  - 3) Proportion of the room (room index) ( $k_r$ ),
  - 4) Reflectance of internal surfaces of the room,
  - 5) Depreciation in the lumen output of the lamps after burning their rated life, and
  - 6) Depreciation due to dirt collection on luminaires and room surface.
- b) Coefficient of utilization or utilization factor
  - 1) The compilation of tables for the utilization factor requires a considerable amount of calculations, especially if these tables have to cover a wide range of lighting practices. For every luminaire, the exact light distribution

has to be measured in the laboratory and their efficiencies have to be calculated and measured exactly. These measurements comprise,

- i) the luminous flux radiated by the luminaires directly to the measuring surface;
- ii) the luminous flux reflected and re-reflected by the ceiling and the walls to the measuring surface; and
- iii) the inter-reflections between the ceiling and wall which result in the measuring surface receiving additional luminous flux.

All these measurements have to be made for different reflection factors of the ceiling and the walls for all necessary room indices. These tables have also to indicate the maintenance factor to be taken for the luminous flux depreciation throughout the life of an installation due to ageing of the lamp and owing to the deposition of dirt on the lamps and luminaires and room surfaces.

- 2) The values of the reflection factor of the ceiling and of the wall are as follows;

White and very light colours	0.7
Light colours	0.5
Middle tints	0.3
Dark colours	0.1

For the walls, taking into account the influence of the windows without curtains, shelves, almirahs and doors with different colours, etc, should be estimated.

- c) *Calculation for Determining the Luminous Flux [see Table 22 of SP: 41 (S&T) – 1987 'Handbook on functional requirements of buildings other than industrial buildings']*

$$E_{av} = \frac{\mu \cdot \phi}{A}$$

or,  $\phi = \frac{E_{av} \cdot A}{\mu}$ , for new condition, and

$$\phi = \frac{E_{av} \cdot A}{\mu \cdot d}$$
, for working condition

where

$\phi$  = Total luminous flux of the light sources installed in the room, in lumens;

$E_{av}$  = average illumination level required on the working plane, in lux;

$A$  = area of the working plane, in m<sup>2</sup>;

$\mu$  = utilization factor in new conditions; and

$d$  = maintenance factor.

In practice, it is easier to calculate straightaway the number of lamps or luminaires from:

$$N_{\text{lamp}} = \frac{E_{\text{av}} \cdot A}{\mu \cdot d \cdot \phi_{\text{lamp}}}$$

$$N_{\text{luminaires}} = \frac{E_{\text{av}} \cdot A}{\mu \cdot d \cdot \phi_{\text{luminaires}}}$$

where

$\phi_{\text{lamp}}$  = luminous flux of each lamp, in lumens

$\phi_{\text{luminaires}}$  = luminous flux of each luminaire, in lumens

$N_{\text{lamp}}$  = total number of lamps

$N_{\text{luminaires}}$  = total number of luminaires.

#### 4.3.2.4 Arrangement of the luminaires

This is done to achieve better uniformly distributed illumination. The location of the luminaires has an important effect on the utilization factor.

- a) In general, luminaires are spaced 'x' metre apart in either direction, while the distance of the end luminaire from the wall is '0.5x' metre. The distance 'x' is more or less equal to the mounting height 'H<sub>m</sub>' between the luminaire and the working plane. The utilization factor tables are calculated for this arrangement of luminaires {see Table 22 of the accepted standard [8-1(7)]}.
- b) For small rooms where the room index ( $k_r$ ) is less than 1, the distance 'x' should always be less than  $H_m$ , since otherwise luminaires cannot be properly located. In most cases of such rooms, four or two luminaires are placed for good general lighting. If, however, in such rooms only one luminaire is installed in the middle, higher utilization factors are obtained, but the uniformity of distribution is poor. For such cases, references should be made to the additional tables for  $k_r = 0.6$  to 1.25 for luminaires located centrally.

#### 4.3.3 Artificial Lighting to Supplement Daylighting

**4.3.3.1** The need for general supplementary artificial lighting arises due to diminution of daylighting beyond design hours, that is, for solar altitude below 15° or when dark cloudy conditions occur.

**4.3.3.2** The need may also arise for providing artificial lighting during the day in the innermost parts of the building which cannot be adequately provided with daylighting, or when the outside windows are not of adequate size or when there are unavoidable external obstructions to the incoming daylighting.

**4.3.3.3** The need for supplementary lighting during the day arises, particularly when the daylighting on the working plane falls below 100 lux and the surrounding luminance drops below 19 cd/m<sup>2</sup>.

**4.3.3.4** The requirement of supplementary artificial lighting increases with the decrease in daylighting availability. Therefore, conditions near sunset or sunrise or equivalent conditions due to clouds or obstructions, etc, represent the worst conditions when the supplementary lighting is most needed.

**4.3.3.5** The requirement of supplementary artificial lighting when daylighting availability becomes poor may be determined from Fig. 3 for an assumed ceiling height of 3.0 m, depending upon floor area, fenestration percentage and room surface reflectance. Cool daylight fluorescent tubes are recommended with semi-direct luminaires. To ensure a good distribution of illumination, the mounting height should be between 1.5 m and 2.0 m above the work plane for a separation of 2.0 m to 3.0 m between the luminaires. Also, the number of lamps should preferably be more in the rear half of the room than in the vicinity of windows. The following steps may be followed for using Fig. 3 for determining the number of fluorescent tubes required for supplementary daylighting.

- a) Determine fenestration percentage of the floor area, that is,

$$\frac{\text{Window area}}{\text{Floor area}} \times 100$$

- b) In Fig. 3, refer to the curve corresponding to the percent fenestration determined above and the set of reflectances of ceiling, walls and floor actually provided.
- c) For the referred curve of Fig. 3 read, along the ordinate, the number of 40 W fluorescent tubes required, corresponding to the given floor area on the abscissa.

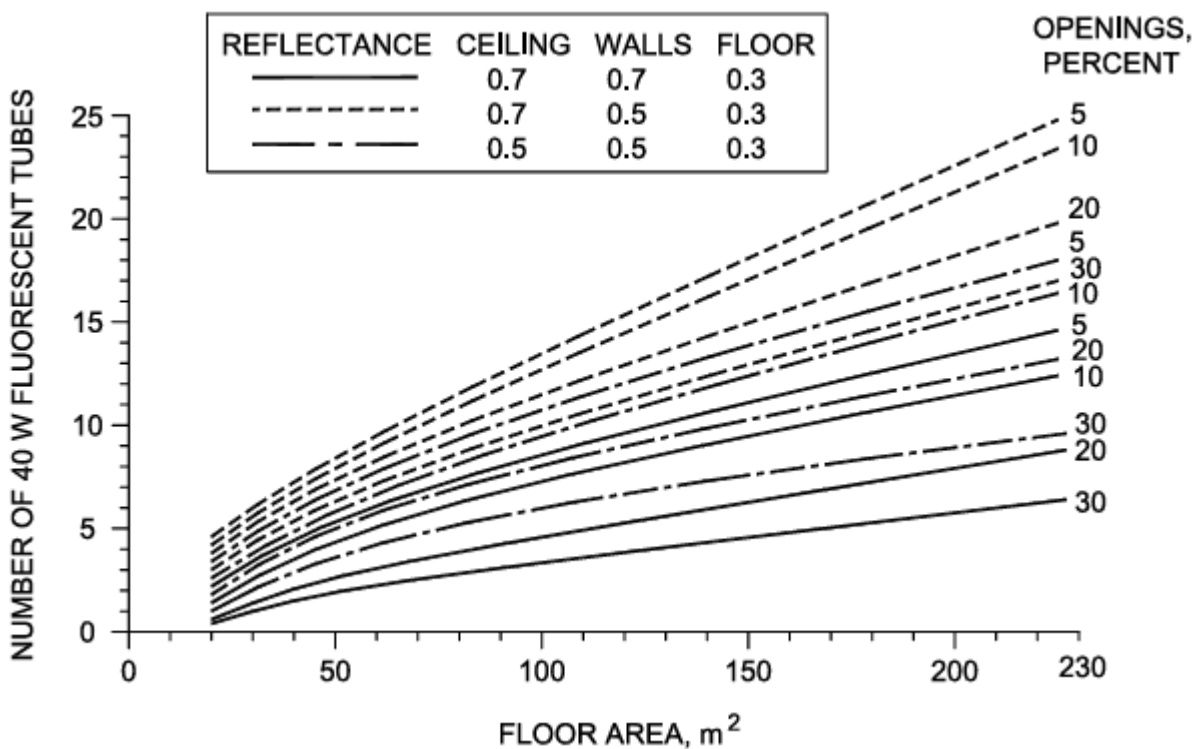

FIG. 3 SUPPLEMENTARY ARTIFICIAL LIGHTING FOR 40W FLUORESCENT TUBES

**4.3.4** For detailed information on the design aspects and principles of artificial lighting, reference may be made to good practice [8-1(2)].

**4.3.5** For specific requirements for lighting of special occupancies and areas, reference may be made to good practice [8-1(5)].

**4.3.6** Electrical installation aspect for artificial lighting shall be in accordance with Part 8 'Building Services', Section 2 'Electrical and Allied Installations' of the Code.

**4.4 Energy Conservation in Lighting**

**4.4.1** A substantial portion of the energy consumed on lighting may be saved by utilization of daylight and rational design of supplementary artificial lights.

**4.4.2** Daytime use of artificial lights may be minimized by proper design of windows for adequate daylight indoors. Daylighting design should be according to **4.2**.

**4.4.3** Fenestration expressed as percentage of floor area required for satisfactory visual performance of a few tasks for different separation to height ( $S/H$ ) ratio of external obstructions such as opposite buildings may be obtained from the design nomogram (see Fig. 4). The obstructions at a distance of three times their height or more ( $S/H > 3$ ) from a window façade are not significant and a window facing such an obstruction may be regarded as a case of unobstructed window.



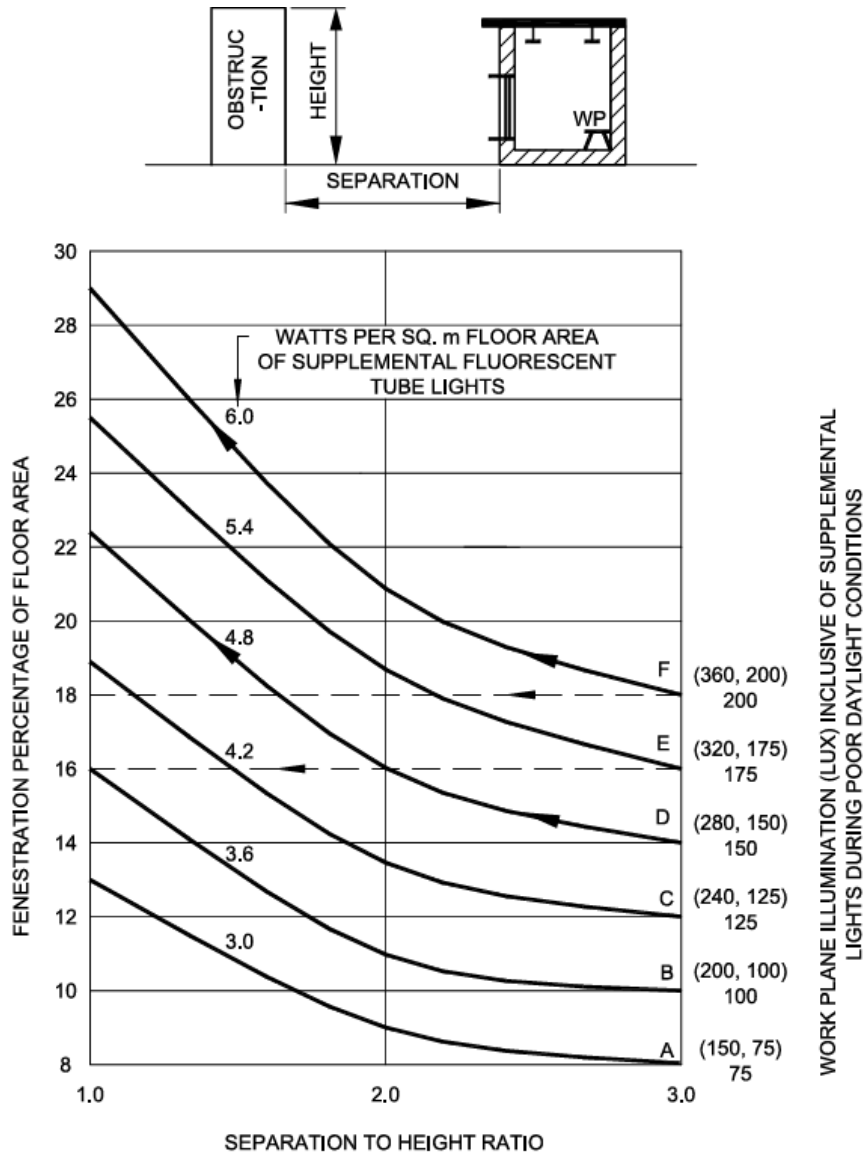

FIG. 4 NOMOGRAPH FOR DAYLIGHTING AND SUPPLEMENTAL LIGHTING DESIGN OF BUILDING

**4.4.3.1** The nomogram consists of horizontal lines indicating fenestration percentage of floor area and vertical lines indicating the separation to height ratio of external obstructions such as opposite buildings. Any vertical line for separation to height ratio other than already shown in the nomogram (1.0, 2.0 and 3.0) may be drawn by designer, if required. For cases where there is no obstruction, the ordinate corresponding to the value 3.0 may be used. The value of percentage fenestration and separation to height ratio are marked on left hand ordinate and abscissa respectively. The illumination levels are marked on the right hand ordinate. The values given within brackets are the illumination levels on the work plane at center and rear of the room. The wattage of fluorescent tubes required per square metre of the floor area for different illumination levels is shown on each curve.

**4.4.3.2** Following assumptions have been made in the construction of the nomogram:

- a) An average interior finish with ceiling white, walls off white and floor grey has been assumed.
- b) Ceiling height of 3m, room depths up to 10 m and floor area between 30 m<sup>2</sup> and 50 m<sup>2</sup> have been assumed. For floor area beyond 50 m<sup>2</sup> and less than 30 m<sup>2</sup>, the values of percent fenestration as well as wattage per m<sup>2</sup> should be multiplied by a factor of 0.85 and 1.15, respectively.
- c) It is assumed that windows are of metallic sashes with louvers of width up to 600 mm or a *Chhajja* (balcony projection) at ceiling level of width up to 2.0 m. For wooden sashes, the window area should be increased by a factor of about 1.1.
- d) Luminaires emanating more light in the downward direction than upward direction (such as reflectors with or without diffusing plastics) and mounted at a height of 1.5 m to 2.0 m above the work plane have been considered.

#### 4.4.3.3 Method of use

The following steps shall be followed for the use of nomogram:

- a) *Step 1* – Decide the desired illumination level depending upon the task illumination requirement in the proposed room and read the value of watts per square metre on the curve corresponding to the required illumination level.
- b) *Step 2* – Fix the vertical line corresponding to the given separation to height ratio of opposite buildings on the abscissa. From the point of intersection of this vertical line and the above curve move along horizontal and read the value of fenestration percent on the left hand ordinate.
- c) *Step 3* – If the floor area is greater than 50 m<sup>2</sup> or if it is less than 30 m<sup>2</sup>, the value of watts per m<sup>2</sup> as well as fenestration percent may be easily determined for adequate daylighting and supplemental artificial lighting for design purposes. However, if the fenestration provided is less than the required value, the wattage of supplementary artificial lights should be increased proportionately to make up for the deficiency of natural illumination.

**4.4.4** For good distribution of day light on the working plane in a room, window height, window width and height of sill should be chosen in accordance with the following recommendations:

- a) In office buildings windows of height 1.2 m or more in the centre of a bay with sill level at 1.0 to 1.2 m above floor and in residential buildings windows of height 1.0 m to 1.1 m with sill height as 0.9 m to 0.7 m above floor are recommended for good distribution of daylight indoors. Window width can accordingly be adjusted depending upon the required fenestration percentage of the floor area.
- b) If the room depth is more than 10 m, windows should be provided on opposite sides for bilateral lighting.

- c) It is desirable to have a white finish for ceiling and off white (light colour) to white for walls. There is about 7 percent improvement in lighting levels in changing the finish of walls from moderate to white.

**4.4.5** For good distribution and integration of daylight with artificial lights the following guidelines are recommended:

- a) Employ cool daylight fluorescent tubes for supplementary artificial lighting.
- b) Distribute luminaires with a separation of 2 m to 3 m in each bay of 3 m to 4 m width.
- c) Provide more supplementary lights such as twin tube luminaires in work areas where daylight is expected to be poor for example in the rear region of a room having single window and in the central region of a room having windows on opposite walls. In the vicinity of windows only single tube luminaires should be provided.

#### **4.4.6** *Artificial Lighting*

Energy conservation in lighting is affected by reducing wastage and using energy effective lamps and luminaires without sacrificing lighting quality. Measures to be followed comprise utilization of daylight, energy effective artificial lighting design by providing required illumination where needed, turning off artificial lights when not needed, maintaining lighter finishes of ceiling, walls and furnishings, and implementing periodic schedule for cleaning of luminaires and group replacement of lamps at suitable intervals. Choice of light sources with higher luminous efficacy and luminaires with appropriate light distribution is the most effective means of energy saving in lighting. However, choice of light sources also depends on the other lighting quality parameters like colour rendering index and colour temperature or appearance. The choice of light sources type also depends on the desired mounting height in the interiors.

##### **4.4.6.1** *Efficient artificial light sources and luminaires*

Luminous efficacies of some of the lamps used in lighting of buildings are given in Table 9 along with average life in burning hours, Colour Rendering Index and Colour Temperature. Given the high luminous efficacy that can be achieved with most LED lighting, energy efficiency in lighting can be achieved via space appropriate zoning, identifying the application type (task versus ambient) and careful consideration of lighting quality requirements.

**Table 9 Luminous Efficacy, Life, Lumen Maintenance and Colour Rendition of Light Sources**  
(Clause 4.4.6.1)

Sl No.	Light Source	Wattage Range W	Efficacy lm/W	Average Life h	Lumen Maintenance	Colour Rendition
(1)	(2)	(3)	(4)	(5)	(6)	(7)
i)	Incandescent lamps	15 to 200	12 to 20	500 to 1 000	Fair to good	Very good
ii	Tungsten halogen	300 to 1 500	20 to 27	200 to 2 000	Good to very good	Very good
iii	Slim line fluorescent	18 to 58	57 to 67	5 000	Fair to good	Good
iv	High pressure mercury vapour lamps	60 to 1 000	50 to 65	5 000	Very low to fair	Federate
v	Blended - light lamps	160 to 250	20 to 30	5 000	Low to fair	Federate
v	High pressure sodium vapour lamps	50 to 1 000	90 to 125	10 000 to 15 000	Fair to good	Low to good
v	Metal halide lamps	35 to 2 000	80 to 95	4 000 to 10 000	Very low	Very good
v	Low pressure sodium	10 to 180	100 to 200	10 000 to 20 000	Good to very good	Poor
ix	LED	0.5 to 2.0	60 to 100	10 000	Very good	Good for white LED

#### NOTES

- 1 The table includes lamps and wattages currently in use in buildings in India.
- 2 Luminous efficacy varies with the wattage of the lamp.
- 3 Average life values are from available Indian Standards. Where Indian Standard is not available, values given are only indicative.
- 4 For exact values, it is advisable to contact manufacturers.

**4.4.6.2** For the same lumen output, it is possible to save 50 to 70 percent energy if CFL lamps are replaced with Induction Lighting, and 40 to 60 percent if replaced with LED lamps. Similar energy effective solutions are to be chosen for every application area.

Similarly with white fluorescent tubes recommended for corridors and staircases, the electrical consumption reduces to 1/4.5 of the energy consumption with incandescent lamps.

**4.4.6.3** Efficient luminaire also plays an important role for energy conservation in lighting. The choice of a luminaire should be such that it is efficient not only initially but also throughout its life. Following luminaries are recommended for different locations:

- a) For offices semi-direct type of luminaries are recommended so that both the work plane illumination and surround luminance can be effectively enhanced.
- b) For corridors and stair cases direct type of luminaries with wide spread of light distributions are recommended.
- c) In residential buildings, glare free wide spread of light distributions are recommended.

#### **4.4.7** *Cleaning Schedule for Window Panes and Luminaires*

Adequate schedule for cleaning of window panes and luminaries will result in significant advantage of enhanced daylight and lumen output from luminaries. Frequent cleaning of windows will tend to reduce the duration over which artificial lights will be used and minimize the wastage of energy. Depending upon the location of the building a cleaning interval of three to six months is recommended for cleaning of luminaires.

#### **4.4.8** *Photocontrols for Artificial Lights*

There is a considerable wastage of electrical energy in lighting of buildings due to carelessness in switching off lights even when sufficient daylight is available indoors. In offices and commercial buildings, occupants may switch on lights in the morning and keep them on throughout the day. When sufficient daylight is available inside, suitable photo controls can be employed to switch off the artificial lights and thus prevent the wastage of energy.

The photocontrol should have the following features:

- a) An integrated photocontrol system continually measures the amount of visible light under the lighting fixture and maintains the lux levels as referred in Table 5.
- b) An integrated photocontrol system should maintain six daylighting scenarios that can be adjusted by the user namely; daytime occupied, daytime unoccupied, sunset occupied, sunset unoccupied, night time occupied and night time unoccupied.
- c) The photocontrol sensor should have a 60° cone of reference to measure the amount of light on the work surface.
- d) Photocontrol, along with supporting lighting based on influx of natural light, should have controls for intelligent 'occupancy based shut-off' system to control which areas need lighting at any moment.
- e) The controls should maintain a decent standard of 'ease of use' for occupants as well as building staff.

#### 4.4.9 Solar Photovoltaic Systems (SPV)

Solar photovoltaic system enables direct conversion of sunlight into electricity and is viable option for lighting purpose in remote non grid areas. The common SPV lighting systems are:

- a) Solar lantern,
- b) Fixed type solar home lighting system, and
- c) Street lighting system.

**4.4.9.1** SPV lighting system should preferably be provided with CFL for energy efficiency.

**4.4.9.2** Invertors used in buildings for supplying electricity during the power cut period should be charged through SPV system.

**4.4.9.3** Regular maintenance of SPV system is necessary for its satisfactory functioning.

**4.4.10** Lighting shelves and light pipes may be explored for utilization and integration in the lighting design.

### 4.5 Circadian Lighting

Light is fundamental to human health and well-being, extending beyond its role in vision. It is the principal regulator of our circadian rhythm, profoundly influencing visual experience, physiological processes, and emotional state. Thus, human-centric lighting, designed for human health and well-being, is essential.

Human physiology evolved under natural sunlight. Ideally, we would experience abundant daylight exposure, gradually decreasing in the evening, with minimal light at night. Modern indoor lifestyles disrupt this natural rhythm. Optimizing indoor environments to emulate this 24 h light-dark cycle can significantly improve sleep quality and promote rejuvenation, with the added benefit of naturally sustained energy.

Light's influence on human health stems from its role in regulating the body's internal clock. The circadian rhythm governs diverse physiological functions, from sleep-wake cycles and mood to overall health. This system is orchestrated by the suprachiasmatic nucleus (SCN) in the brain, which relies on consistent light-dark patterns, reflecting our attunement to the diurnal and seasonal rhythms of daylight availability.

The early 2000s saw the discovery of specialized retinal light-sensitive cells, peaking at around 480 nm (cyan), leading to the concepts of "biologically active" or "circadian light". The melanopic daylight efficacy ratio (melanopic DER) and melanopic equivalent daylight illuminance (melanopic EDI) provide metrics for assessing light's efficacy in supporting our biological rhythms.

In practice, morning light acts as a critical entraining cue, signalling the body to transition to a state of wakefulness and activity. Exposure to bright light during the day further strengthens the circadian rhythm, which plays a vital role in regulating sleep-wake cycles, daytime engagement, and mood. Conversely, darkness at night-

time is essential for promoting restorative sleep, a process crucial for overall health and well-being.

#### **4.5.1 Need for Supplementary Artificial Circadian Lighting**

Artificial circadian lighting is advised in spaces where permanent day-active occupants spend more than 4 h between sunrise and sunset and do not have a direct line of sight to any external windows from their general working area.

In spaces where artificial circadian lighting cannot be incorporated due to functional considerations (for example, museums, movie theatres), break rooms for day-active permanent occupants may be equipped with circadian lighting.

#### **4.5.2 Characteristics of supplementary Artificial Circadian Lighting**

In spaces where supplementary artificial is implemented, it shall have following features:

- a) The lighting system shall include dynamic controls that enable gradual changes in light intensity and colour temperature to mimic natural daylight cycles.
- b) Lux levels (vertical illuminance at the occupant positions) shall be modulated based on time of day to ensure sufficient light exposure during the day and reduced exposure in the evening time following the best-practice for circadian lighting design.

### **4.6 Outdoor Lighting**

Outdoor lighting plays a crucial role in ensuring safety, security, and functionality in various environments, while contributing to energy conservation and minimizing environmental impacts. To achieve these objectives, outdoor lighting shall be designed and managed in accordance with the accepted standard [8-1(8)] guidelines, focussing on energy efficiency and minimizing light pollution.

#### **4.6.1 Lighting Design and Light Zones**

Outdoor lighting designs shall adhere to energy efficiency measures and address the requirements of different light zones, as per the accepted standard [8-1(8)]:

- a) *Urban zones* – Lighting intensity should be optimized for high activity areas, using energy-efficient technologies such as LEDs and lighting controls to ensure energy savings.
- b) *Suburban zones* – Lighting should be designed for moderate activity areas with an emphasis on reducing unnecessary energy consumption, utilizing dimming controls or motion sensors.
- c) *Rural zones* – Lighting shall be kept minimal, ensuring safety while limiting light pollution. Energy-efficient, low-intensity lighting should be implemented.

These zones shall serve as guidelines, and lighting levels should align with the specific needs of the location while minimizing energy consumption as required by special publication.

NOTE – Special publication may be Energy Conservation and Sustainable Building Code 2024.

#### 4.6.2 Energy Efficiency and Light Pollution Mitigation

To comply with the accepted standard [8-1(8)] and reduce light pollution, outdoor lighting systems shall incorporate the following:

- a) *Energy-efficient light sources* – Use of LEDs or other high-efficiency light sources with appropriate lumen output to reduce energy consumption.
- b) *Fully shielded and full cut-off fixtures* – These shall be implemented to prevent upward light emission and sky glow, focusing light where needed to minimize spillover and improve energy use.
- c) *Lighting controls* – The accepted standard [8-1(8)] compliant controls, such as timers, dimmers, and motion sensors, should be employed to reduce lighting during periods of low activity, contributing to energy savings.
- d) *Luminaire efficacy* – All outdoor lighting luminaires shall meet the minimum efficacy requirements as specified in the accepted standard [8-1(8)] for energy conservation and reduced power consumption.

#### 4.6.3 Effects of Light Pollution on Life

Excessive outdoor lighting, if not properly controlled, may have adverse effects on human, animal, and plant life:

- a) *Human Health* – Exposure to artificial light at night can disrupt circadian rhythms, leading to potential health risks such as sleep disorders and increased stress. Lighting design should prioritize human well-being by controlling glare and unnecessary brightness.
- b) *Animal Life* – Wildlife, particularly nocturnal species, may experience disruptions in natural behaviours, such as feeding and mating, due to poorly managed artificial lighting. The accepted standard [8-1(8)] compliant lighting should minimize impact on ecosystems.
- c) *Plant Life* – Artificial lighting may affect plant growth cycles, leading to ecological imbalance. Properly designed lighting should reduce this risk by controlling light spill and adhering to the lighting recommendations of accepted standard [8-1(8)].

## 5 VENTILATION

### 5.1 General

Natural Ventilation of buildings is required to supply outdoor air for the respiration of occupants, to remove any products of combustion or other contaminants in the air and to provide such thermal environments as will assist in the maintenance of heat balance of the body in order to prevent discomfort and injury to the health of the occupants. The natural ventilation through building envelope elements such as operable windows, skylights, and ventilators help maintain the desired quality of air and thermal comfort conditions when outdoor air and thermal environments are conducive to the cause.



## 5.2 Design Considerations

### 5.2.1 Respiration

Supply of fresh air to provide oxygen for the human body for elimination of waste products and to maintain carbon dioxide concentration in the air within safe limits rarely calls for special attention as enough outside air for this purpose normally enters the areas of occupancy through crevices and other openings.

**5.2.1.1** In normal habitable rooms devoid of smoke generating source, the content of carbon dioxide in air rarely exceeds 0.5 percent to 1 percent and is, therefore, incapable of producing any ill effect. The amount of air required to keep the concentration down to 1 percent is very small. The change in oxygen content is also too small under normal conditions to have any ill effects; the oxygen content may vary quite appreciably without noticeable effect, if the carbon dioxide concentration is unchanged.

### 5.2.2 Vitiating by Body Odours

Where no products of combustion or other contaminants are to be removed from air, the amount of fresh air required for dilution of inside air to prevent vitiating of air by body odours, depends on the air space available per person and the degree of physical activity; the amount of air decreases as the air space available per person increases, and it may vary from 20 m<sup>3</sup> to 30 m<sup>3</sup> per person per hour. In rooms occupied by only a small number of persons such an air change will automatically be attained in cool weather by normal leakage around windows and other openings and this may easily be secured in warm weather by keeping the openings open.

No standards have been laid down under the *Factories Act*, 1948 as regards the amount of fresh air required per worker or the number of air changes per hour. Section 16 of the *Factories Act*, 1948 relating to over-crowding requires that at least 14 m<sup>3</sup> to 16 m<sup>3</sup> of space shall be provided for every worker and for the purpose of that section no account shall be taken of any space in a work room which is more than 4.25 m above the floor level.

NOTE – Vitiating of the atmosphere can also occur in factories by odours given off due to contaminants of the product itself, say for example, from tobacco processing in a 'BEEDI' factory. Here the ventilation will have to be augmented to keep odours within unobjectionable levels.

#### 5.2.2.1 Recommended values for air changes

The standards of general ventilation are recommended/based on maintenance of required oxygen, carbon dioxide and other air quality levels and for the control of body odours when no products of combustion or other contaminants are present in the air; the values of air changes should be as follows:

<i>Sl No.</i>	<i>Application</i>	<i>Air Change per Hour</i>
(1)	(2)	(3)
1)	Assembly rooms	4-8
2)	Bakeries	20-30
3)	Banks/building societies	4-8
4)	Bathrooms	6-10
5)	Bedrooms	2-4
6)	Billiard rooms	6-8
7)	Boiler rooms	see Note 2
8)	Cafes and coffee bars	10-12
9)	Canteens	8-12
10)	Cellars	3-10
11)	Changing rooms	6-10
12)	Churches	1-3
13)	Cinemas and theatres	10-15
14)	Club rooms	12, <i>Min</i>
15)	Compressor rooms	10-12
16)	Conference rooms	8-12
17)	Corridors	5-10
18)	Dairies	8-12
19)	Dance halls	12, <i>Min</i>
20)	Dye works	20-30
21)	Electroplating shops	10-12
22)	Engine rooms/DG Rooms/GG Rooms	see Note 2
23)	Entrance halls	3-5
24)	Factories and work shops	8-10
25)	Foundries	15-30
26)	Garages	6-8
27)	Glass houses	25-60
28)	Gymnasium	6, <i>Min</i>
29)	Hair dressing saloon	10-15
30)	Hospitals sterilising	15-25
31)	Hospital wards	6-8
32)	Hospital domestic	15-20
33)	Laboratories	6-15
34)	Launderettes	10-15
35)	Laundries	10-30
36)	Lavatories	6-15
37)	Lecture theatres	5-8
38)	Libraries	3-5
39)	Lift cars	20, <i>Min</i>
40)	Living rooms	3-6
41)	Mushroom houses	6-10
42)	Offices	6-10
43)	Paint shops(not cellulose)	10-20
44)	Photo and X-ray dark room	10-15
45)	Public house bars	12, <i>Min</i>
46)	Recording control rooms	15-25
47)	Recording studios	10-12
48)	Restaurants	8-12
49)	Schoolrooms	5-7
50)	Shops and supermarkets	8-15
51)	Shower baths	15-20
52)	Stores and warehouses	3-6
53)	STP rooms	30, <i>Min</i>
54)	Squash courts	4, <i>Min</i>
55)	Swimming baths	10-15

<i>Sl No.</i>	<i>Application</i>	<i>Air Change per Hour</i>
(1)	(2)	(3)
56)	Toilets	6-10
57)	Underground vehicle parking	6, <i>Min</i>
58)	Utility rooms	15-30
59)	Welding shops	15-30

**NOTES**

- 1 The ventilation rates may be increased by 50 percent where heavy smoking occurs or if the room is below the ground.
- 2 The ventilation rate shall be as per **14.2.1** of Part 8 'Building Services', Section 3 'Air Conditioning, Heating and Mechanical Ventilation' of the Code.

**5.2.3 Heat Balance of Body**

Especially in hot weather, when the thermal environment inside the room is worsened by the heat given off by machinery, occupants and other sources, the prime need for ventilation is to provide such a thermal environment as will assist in the maintenance of heat balance of the body in order to prevent discomfort and injury to health. Excess of heat either from increased metabolism due to physical activity of persons or gains from a hot environment has to be offset to maintain normal body temperature (appx. 37 °C). Heat exchange of the human body with respect to the surroundings is determined by the temperature and humidity gradient between the skin and the surroundings and other factors, such as the age of person, clothing, etc, and the latter depends on air temperature (dry bulb temperature), relative humidity, radiation from the solid surroundings and rate of air movement. The volume of outside air to be circulated through the room is, therefore, governed by the physical considerations of controlling the temperature, air distribution or air movement. Air movement and air distribution may, however, be achieved by recirculation of the inside air rather than bringing in all outside air. However, fresh air supply or the circulated air will reduce heat stress by dissipating heat from the body by evaporation of the sweat, particularly when the relative humidity is high and the air temperature is near body temperature.

**5.2.3.1 Indices of thermal comfort**

Thermal comfort is that condition of a thermal environment under which a person can maintain a body heat balance at normal body temperature and without perceptible sweating. Limits of comfort vary considerably according to studies carried out in India and abroad.

The thermal indices which find applications for Indian climate are as follows:

- a) Effective temperature (ET),
- b) Tropical summer index (TSI), and
- c) Operative temperature based Adaptive thermal comfort.

### 5.2.3.1.1 Effective temperature (ET)

Effective temperature is defined as the temperature of still, saturated air which has the same general effect upon comfort as the atmosphere under investigation. Combinations of temperature, humidity and wind velocity producing the same thermal sensation in an individual are taken to have the same effective temperature.

Initially two scales were developed, one of which referred to men stripped to the waist and called the basic scale. The other applies to men fully clad in indoor clothing and called the normal scale of effective temperature. Bedford (1946) proposed the use of globe temperature reading instead of the air temperature reading to make allowance for the radiant heat. This scale is known as the corrected effective temperature (CET) scale. No allowance, however, was made for the different rates of energy expenditure. The scale was compiled only for men either seated or engaged in light activity.

Figure 5 represents the corrected effective temperature nomogram. The CET can be obtained by connecting the appropriate points representing the dry bulb (or globe) and wet bulb temperatures and reading the CET value at the intersection of this line with the relevant air velocity curve from the family of curves for various air velocities running diagonally upwards from left to right.

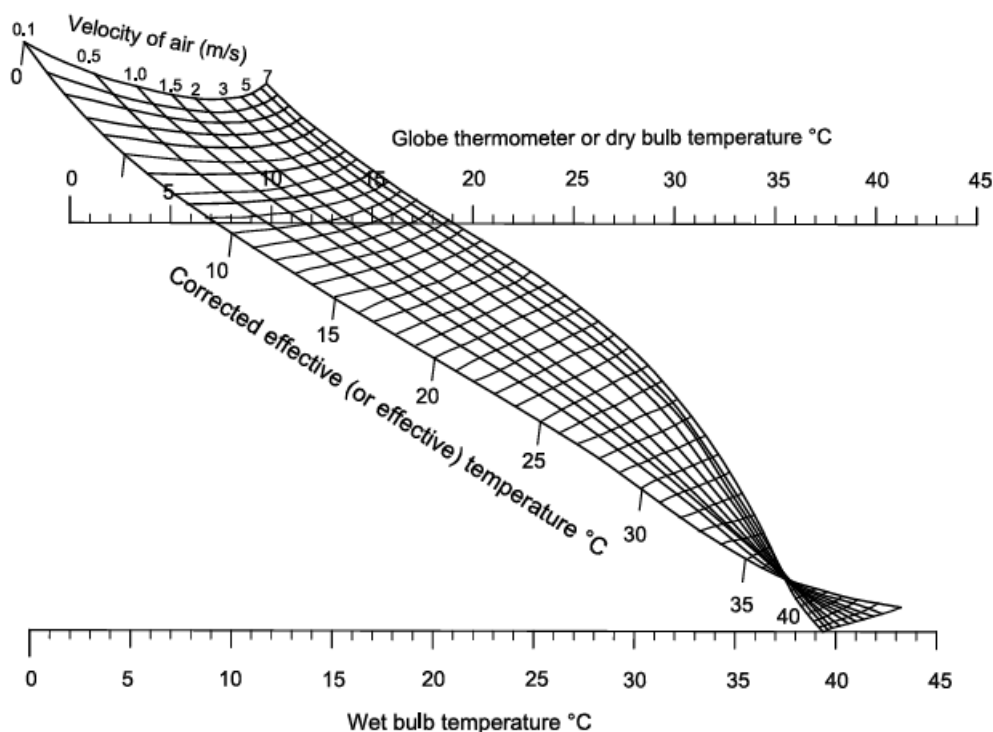

FIG. 5 CORRECTED EFFECTIVE TEMPERATURE NOMOGRAM

The effective temperature scale may be considered to be reasonably accurate in warm climates where the heat stress is not high but it may be misleading at high levels of heat stress. There appears to be an inherent error in this scale if used as an index of physiological strain, the error increasing with the severity of the environmental conditions. For low and moderate degrees of heat stress, the effective temperature

scales appear to assess climatic heat stress with an accuracy which is acceptable for most practical purposes.

### 5.2.3.1.2 Tropical Summer Index (TSI)

The TSI is defined as the temperature of calm air, at 50 percent relative humidity which imparts the same thermal sensation as the given environment. The 50 percent level of relative humidity is chosen for this index as it is a reasonable intermediate value for the prevailing humidity conditions. Mathematically, TSI (°C) is expressed as:

$$TSI = 0.745t_g + 0.308t_w - 2.06\sqrt{v + 0.841}$$

where,

$t_w$  = wet bulb temperature, in °C;  
 $t_g$  = globe temperature, in °C; and  
 $V$  = air speed, in m/s.

The thermal comfort of a person lies between TSI values of 25 °C and 30 °C with optimum condition at 27.5 °C. Air movement is necessary in hot and humid weather for body cooling. A certain minimum desirable wind speed is needed for achieving thermal comfort at different temperatures and relative humidities. Such wind speeds are given in Table 10. These are applicable to sedentary work in offices and other places having no noticeable sources of heat gain. Where somewhat warmer conditions are prevalent, such as in godowns and machine shops and work is of lighter intensity, and higher temperatures can be tolerated without much discomfort, minimum wind speeds for just acceptable warm conditions are given in Table 11. For obtaining values of indoor wind speed above 2.0 m/s, mechanical means of ventilation may have to be adopted (see also Part 8 'Building services', Section 3 'Air Conditioning, Heating and Mechanical Ventilation' of the Code).

The warmth of the environment was found tolerable between 30 °C and 34 °C (TSI), and too hot above this limit. On the lower side, the coolness of the environment was found tolerable between 19 °C and 25°C (TSI) and below 19°C (TSI), it was found too cold.

**Table 10 Desirable Wind Speeds (m/s) for Thermal Comfort Conditions**  
(Clause 5.2.3.1.2)

Sl. No.	Dry Bulb Temperature, °C	Relative Humidity, Percent						
		30	40	50	60	70	80	90
(1)	(2)	(3)	(4)	(5)	(6)	(7)	(8)	(9)
i)	28	1)	1)	1)	1)	1)	1)	1)
ii)	29	1)	1)	1)	1)	1)	0.06	0.19
iii)	30	1)	1)	1)	0.06	0.24	0.53	0.85
iv)	31	1)	0.06	0.24	0.53	1.04	1.47	2.10
v)	32	0.20	0.46	0.94	1.59	2.26	3.04	2)
vi)	33	0.77	1.36	2.12	3.00	2)	2)	2)
vii)	34	1.85	2.72	2)	2)	2)	2)	2)

Sl. No.	Dry Bulb Temperature, °C	Relative Humidity, Percent						
		30	40	50	60	70	80	90
(1)	(2)	(3)	(4)	(5)	(6)	(7)	(8)	(9)
viii)	35	3.20	2)	2)	2)	2)	2)	2)

1) None

2) Higher than those acceptable in practice.

**Table 11 Minimum Wind Speeds (m/s) for Just Acceptable Warm Conditions**  
(Clause 5.2.3.1.2)

Sl No.	Dry Bulb Temperature, °C	Relative Humidity, Percent						
		30	40	50	60	70	80	90
(1)	(2)	(3)	(4)	(5)	(6)	(7)	(8)	(9)
i)	28	1)	1)	1)	1)	1)	1)	1)
ii)	29	1)	1)	1)	1)	1)	1)	1)
iii)	30	1)	1)	1)	1)	1)	1)	1)
iv)	31	1)	1)	1)	1)	1)	0.06	0.23
v)	32	1)	1)	1)	0.09	0.29	0.60	0.94
vi)	33	1)	0.04	0.24	0.60	1.04	1.85	2.10
vii)	34	0.15	0.46	0.94	1.60	2.26	3.05	2)
viii)	35	0.68	1.36	2.10	3.05	2)	2)	2)
ix)	36	1.72	2.70	2)	2)	2)	2)	2)

1) None

2) Higher than those acceptable in practice.

#### 5.2.4 Design of Indoor Conditions as per Adaptive Thermal Comfort Model

Air conditioning systems for interior spaces intended for human occupancy shall be sized for not more than 26°C for cooling and for not less than 18°C for heating at an occupied level. Design based on an adaptive thermal comfort model can play a major role in reducing energy use whilst maintaining the comfort, productivity and well-being of occupants. This approach recognizes that people's thermal comfort needs depend on their past and present context and that these needs vary with the outdoor environmental conditions of their location.

People living year-round in air-conditioned spaces are likely to develop high expectations for homogeneity and cool temperatures and may become quite critical if thermal conditions deviate from the centre of the comfort zone they have come to expect. In contrast, people who live or work in naturally ventilated buildings, can control their immediate interior spaces, and get accustomed to variable indoor thermal conditions that reflect local patterns of daily and seasonal climate changes. Their thermal perceptions, preferences, as well as tolerances, are likely to extend over a wider range of temperatures. It allows buildings to operate within broader temperature bands. The specification of a broader comfort band suited to the Indian context has the potential to reduce the use of energy-intensive space cooling for buildings in India. This Section deals with the adaptive thermal comfort model which differentiates the

thermal response of occupants in air-conditioned and naturally ventilated buildings. It is imperative to specify indoor comfort conditions separately for buildings depending upon their operation, namely, air-conditioned buildings as well as naturally ventilated buildings.

- a) Operative temperature is a more suitable index to measure thermal comfort in a building having low indoor air velocities since the index also accounts for the impact of building surface temperatures (radiant temperatures) on human comfort. Indoor operative temperature, for sedentary activities, can be approximated as an arithmetic mean of indoor air and radiant temperatures. For operating air conditioning system based on operative temperature, the prevalent conditions along with the historical outdoor trend can be used to derive suitable operative temperature limits. Typical climatic conditions of various Indian cities is in public domain.
- b) In case of buildings having higher indoor air velocity (more than 0.5 m/s), effective temperature-based approach is recommended since in addition to all factors considered in operative temperature, it also takes into account heat dissipation from the human body through convective heat transfer. High air velocity can give the opportunity to keep higher air temperature without compromising thermal comfort. However, it is also suggested to keep under consideration noise and other effects of high indoor air velocity. For annual indoor design conditions as per the adaptive model, for Indian cities, reference may be made to Annex A of Part 8 Section 3 'Air Conditioning, Heating and Mechanical Ventilation' of this Code. These are indicative simplified values. They have been derived using typical meteorological year (TMY) files. More accurate design conditions can be derived using the following equations

#### 5.2.4.1 Design Conditions for Commercial Buildings

It is recommended to use the below-mentioned set of adaptive thermal comfort equations for Commercial buildings. Please note that equations (a) to (d) are best suited for the 30-day outdoor running mean temperatures between 13°C and 38.5°C.

- a) For naturally ventilated (NV) commercial buildings – The following equation should be used for design and operation of naturally ventilated (NV) buildings. It indicates that occupants in NV buildings thermally adapt to the outdoor temperature of their location.

$$\text{Indoor operative temperature} = (0.54 \times \text{Outdoor Temperature}) + 12.83$$

Where, indoor operative temperature (in °C) is neutral temperature, and Outdoor Temperature is the 30 day outdoor running mean air temperature (in °C).

The 90 percent acceptability range for naturally ventilated buildings is  $\pm 2.38^\circ\text{C}$ .

- b) For mixed-mode (MM) operation commercial buildings – Mixed-mode buildings, where HVAC is operated only during extreme outdoor conditions, are becoming prevalent in India. The occupants in mixed-mode buildings are more adaptive

when compared to those in air conditioned buildings and somewhat less adaptive compared to occupants in naturally ventilated buildings.

Indoor operative temperature  $= (0.28 \times \text{Outdoor Temperature}) + 17.87$

Where, indoor operative temperature (in °C) is neutral temperature, and Outdoor Temperature is the 30 day outdoor running mean air temperature (in °C).

The 90 percent acceptability range for mixed-mode buildings is  $\pm 3.46^\circ\text{C}$ .

#### 5.2.4.2 Design Conditions for Residential Buildings

The following equation shall be used for determining adaptive thermal comfort in residential buildings, applicable for outdoor running mean temperatures between 7°C and 33°C.

a) Indoor operative temperature  $= (0.42 \times \text{Outdoor Temperature}) + 17.45$

Acceptability range:  $\pm 2.15^\circ\text{C}$

Indoor operative temperature  $= (0.42 \times \text{Outdoor Temperature}) + 17.45$

It is recommended to use the below-mentioned adaptive thermal comfort equation for residential buildings, for all operation modes. Please note that the equation given in 5.2.4.2 (a) is best suited for the 30 day outdoor running mean temperatures between 7°C and 33°C.

Where, Indoor operative temperature (in °C) is neutral temperature, and outdoor temperature is the 30-day outdoor running mean air temperature (in °C). The 90 percent acceptability range for conditioned buildings is  $\pm 2.15^\circ\text{C}$ .

We recommend that the adaptive comfort values derived using equations given in 5.2.4.1 for commercial, and the equation given in 5.2.4.2 for residential buildings are best suited for indoor relative humidity conditions (RH in percentage) between 25 percent and 75 percent.

#### 5.2.5 Minimum Outside Fresh Air

Minimum outside fresh air applicable to only fully air-conditioned buildings. The table 12 prescribes minimum supply rates of acceptable outdoor air required for acceptable indoor air quality. These requirements for ventilation of health care facilities (hospitals, nursing and convalescent homes) are separately covered in Table 13. These values have been prescribed to dilute human bio effluents and other contaminants with an adequate margin of safety and to account for health variations among people and varied activity levels. The values prescribed in the table shall be used in conjunction with the accompanying notes. Naturally ventilated spaces and mixed mode spaces, while getting operated in naturally ventilated mode, will have to rely on outdoor air using fenestration systems. The quantity and distribution of introduced fresh air should take into account the natural infiltration of the building. The proportion of fresh air



introduced into air conditioned building may be varied to achieve economical and efficient operation. When the fresh air can provide a useful cooling effect, the quantity shall be controlled through an air-side economizer to balance the cooling demand. However, when the air is too warm or humid the quantity may be reduced to a minimum to reduce the cooling load.

**Table 12 Minimum Ventilation Rates in Breathing Zone**  
(Clauses 5.2.5)

(This table is not valid in isolation; it shall be used in conjunction with the accompanying notes.)

Sl. No.	Occupancy Category	People Outdoor Air Rate, $R_p$				Notes	Default Values			Air <sup>1)</sup> Class
		Area Outdoor Air Rate, $R_a$		Occupant Density (see Note 4)	Combined Outdoor Air Rate (see Note 4)					
		cfm/person	l/s.person		cfm/ft <sup>2</sup>		l/s.m <sup>2</sup>	Persons per 1 000 ft <sup>2</sup> or per 100 m <sup>2</sup>	cfm/person	
(1)	(2)	(3)	(4)	(5)	(6)	(7)	(8)	(9)	(10)	(11)
<b>i)</b>	<b>Correctional facilities:</b>									
a)	Cell	5	2.5	0.12	0.6		25	10	4.9	2
b)	Dayroom	5	2.5	0.06	0.3		30	7	3.5	1
c)	Guard Stations	5	2.5	0.06	0.3		15	9	4.5	1
d)	Booking/waiting	7.5	3.8	0.06	0.3		50	9	4.4	2
<b>ii)</b>	<b>Educational facilities:</b>									
a)	Daycare (through age 4)	10	5	0.18	0.9		25	17	8.6	2
b)	Daycare sickroom	10	5	0.18	0.9		25	17	8.6	3
c)	Classrooms (ages 5-8)	10	5	0.12	0.6		25	15	7.4	1
d)	Classrooms (age 9 plus)	10	5	0.12	0.6		35	13	6.7	1
e)	Lecture classroom	7.5	3.8	0.06	0.3		65	8	4.3	1

Sl. No.	Occupancy Category	People Outdoor Air Rate, $R_p$				Area Outdoor Air Rate, $R_a$		Notes	Default Values		
		Occupant Density (see Note 4)		Combined Outdoor Air Rate (see Note 4)		Air <sup>1)</sup> Class					
		cfm/person	l/s.person	cfm/ft <sup>2</sup>	l/s.m <sup>2</sup>		Persons per 1 000 ft <sup>2</sup> or per 100 m <sup>2</sup>		cfm/person	l/s.person	
(1)	(2)	(3)	(4)	(5)	(6)	(7)	(8)	(9)	(10)	(11)	
f)	Lecture hall (fixed seats)	7.5	3.8	0.06	0.3		150	8	4.0	1	
g)	Art classroom	10	5	0.18	0.9		20	19	9.5	2	
h)	Science laboratories	10	5	0.18	0.9		25	17	8.6	2	
j)	University/college laboratories	10	5	0.18	0.9		25	17	8.6	2	
k)	Wood/metal shop	10	5	0.18	0.9		20	19	9.5	2	
m)	Computer lab	10	5	0.12	0.6		25	15	7.4	1	
n)	Media centre	10	5	0.12	0.6	See Note 6	25	15	7.4	1	
p)	Music/theatre/dance	10	5	0.06	0.3		35	12	5.9	1	
q)	Multi-use assembly	7.5	3.8	0.06	0.3		100	8	4.1	1	
<b>iii)</b>	<b>Food and beverage service:</b>										
a)	Restaurant dining rooms	7.5	3.8	0.18	0.9		70	10	5.1	2	
b)	Cafeteria/fast-food dining	7.5	3.8	0.18	0.9		100	9	4.7	2	
c)	Bars, cocktail lounges	7.5	3.8	0.18	0.9		100	9	4.7	2	

Sl. No.	Occupancy Category	People Outdoor Air Rate, $R_p$				Notes	Default Values			Air <sup>1)</sup> Class
		Area Outdoor Air Rate, $R_a$		Occupant Density (see Note 4)	Combined Outdoor Air Rate (see Note 4)					
		cfm/person	l/s.person		cfm/ft <sup>2</sup>		l/s.m <sup>2</sup>	Persons per 1 000 ft <sup>2</sup> or per 100 m <sup>2</sup>	cfm/person	
(1)	(2)	(3)	(4)	(5)	(6)	(7)	(8)	(9)	(10)	(11)
<b>iv)</b>	<b>General:</b>									
a)	Break rooms	5	2.5	0.06	0.3		25	10	5.1	1
b)	Coffee stations	5	2.5	0.06	0.3		20	11	5.5	1
c)	Conference/meeting	5	2.5	0.06	0.3		50	6	3.1	1
d)	Corridors	-	-	0.06	0.3		-	-	-	1
e)	Storage rooms	-	-	0.12	0.6	See Note 7	-	-	-	1
<b>v)</b>	<b>Hotels, motels, resorts, dormitories:</b>									
a)	Bedroom/living room	5	2.5	0.06	0.3		10	11	5.5	1
b)	Barracks sleeping areas	5	2.5	0.06	0.3		20	8	4.0	1
c)	Laundry rooms, central	5	2.5	0.12	0.6		10	17	8.5	2
d)	Laundry rooms within dwelling units	5	2.5	0.12	0.6		10	17	8.5	1
e)	Lobbies/pre-function	7.5	3.8	0.06	0.3		30	10	4.8	1
f)	Multipurpose assembly	5	2.5	0.06	0.3		120	6	2.8	1

Sl. No.	Occupancy Category	People Outdoor Air Rate, $R_p$				Area Outdoor Air Rate, $R_a$		Notes	Default Values			Air <sup>1)</sup> Class
		cfm/person		l/s.person		cfm/ft <sup>2</sup>	l/s.m <sup>2</sup>		Occupant Density (see Note 4)  Persons per 1 000 ft <sup>2</sup> or per 100 m <sup>2</sup>	Combined Outdoor Air Rate (see Note 4)		
		cfm/person	l/s.person	cfm/person	l/s.person							
(1)	(2)	(3)	(4)	(5)	(6)	(7)	(8)	(9)	(10)	(11)		
<b>vi)</b>	<b>Office buildings:</b>											
a)	Office space	5	2.5	0.06	0.3		5	17	8.5	1		
b)	Reception Areas	5	2.5	0.06	0.3		30	7	3.5	1		
c)	Telephone/data entry	5	2.5	0.06	0.3		60	6	3.0	1		
d)	Main entry lobbies	5	2.5	0.06	0.3		10	11	5.5	1		
<b>vii)</b>	<b>Miscellaneous spaces:</b>											
a)	Bank vaults/safe deposit	5	2.5	0.06	0.3		5	17	8.5	2		
b)	Computer (not printing)	5	2.5	0.06	0.3		4	20	10.0	1		
c)	Electrical equipment rooms	-	-	0.06	0.3	See Note 7	-	-	-	1		
d)	Elevator machine rooms	-	-	0.12	0.6	See Note 7	-	-	-	1		
e)	Pharmacy (preparation area)	5	2.5	0.18	0.9		10	23	11.5	2		
f)	Photo studios	5	2.5	0.12	0.6		10	17	8.5	1		
g)	Shipping/receiving	-	-	0.12	0.6	See Note 7	-	-	-	1		
h)	Telephone closets	-	-	0.00	0.0		-	-	-	1		

Sl. No.	Occupancy Category	People Outdoor Air Rate, $R_p$				Area Outdoor Air Rate, $R_a$		Notes	Default Values			Air <sup>1)</sup> Class
		cfm/person		l/s.person		cfm/ft <sup>2</sup>	l/s.m <sup>2</sup>		Occupant Density (see Note 4)  Persons per 1 000 ft <sup>2</sup> or per 100 m <sup>2</sup>	Combined Outdoor Air Rate (see Note 4)		
		cfm/person	l/s.person	cfm/person	l/s.person							
(1)	(2)	(3)	(4)	(5)	(6)	(7)	(8)	(9)	(10)	(11)		
j)	Transportation waiting	7.5	3.8	0.06	0.3		100	8	4.1	1		
k)	Warehouses	-	-	0.06	0.3	See Note 7	-	-	-	2		
<b>viii) Public assembly spaces:</b>												
a)	Auditorium seating area	5	2.5	0.06	0.3		150	5	2.7	1		
b)	Places of religious worship	5	2.5	0.06	0.3		120	6	2.8	1		
c)	Courtrooms	5	2.5	0.06	0.3		70	6	2.9	1		
d)	Legislative chambers	5	2.5	0.06	0.3		50	6	3.1	1		
e)	Libraries	5	2.5	0.12	0.6		10	17	8.5	1		
f)	Lobbies	5	2.5	0.06	0.3		150	5	2.7	1		
g)	Museums (children's)	7.5	3.8	0.12	0.6		40	11	5.3	1		
h)	Museums/galleries	7.5	3.8	0.06	0.3		40	9	4.6	1		
<b>ix) Residential:</b>												
a)	Dwelling unit	5	2.5	0.06	0.3	See Notes 8 and 9	See Note 8	-	-	1		
b)	Common corridors	-	-	0.06	0.3	-	-	-	-	1		

Sl. No.	Occupancy Category	People Outdoor Air Rate, $R_p$				Area Outdoor Air Rate, $R_a$		Notes	Default Values			Air <sup>1)</sup> Class
		cfm/person		l/s.person		cfm/ft <sup>2</sup>	l/s.m <sup>2</sup>		Occupant Density (see Note 4)  Persons per 1 000 ft <sup>2</sup> or per 100 m <sup>2</sup>	Combined Outdoor Air Rate (see Note 4)		
		cfm/person	l/s.person	cfm/person	l/s.person							
(1)	(2)	(3)	(4)	(5)	(6)	(7)	(8)	(9)	(10)	(11)		
<b>x)</b>	<b>Retail:</b>											
a)	Sales (except as below)	7.5	3.8	0.12	0.6		15	16	7.8	2		
b)	Mall common areas	7.5	3.8	0.06	0.3		40	9	4.6	1		
c)	Barbershop	7.5	3.8	0.06	0.3		25	10	5.0	2		
d)	Beauty and nail salons	20	10	0.12	0.6		25	25	12.4	2		
e)	Pet shops (animal areas)	7.5	3.8	0.18	0.9		10	26	12.8	2		
f)	Supermarket	7.5	3.8	0.06	0.3		8	15	7.6	1		
g)	Coin-operated laundries	7.5	3.8	0.06	0.3		20	11	5.3	2		
<b>xi)</b>	<b>Sports and entertainment:</b>											
a)	Sports arena (play area)	-	-	0.30	1.5	See Note 10	-	-	-	1		
b)	Gym, stadium (play area)	-	-	0.30	1.5		30	-	-	2		
c)	Spectator areas	7.5	3.8	0.06	0.3		150	8	4.0	1		
d)	Swimming (pool and deck)	-	-	0.48	2.4	See Note 11	-	-	-	2		
e)	Disco/dance floors	20	10	0.06	0.3		100	21	10.3	1		
f)	Health club/aerobics room	20	10	0.06	0.3		40	22	10.8	2		

Sl. No.	Occupancy Category	People Outdoor Air Rate, $R_p$				Area Outdoor Air Rate, $R_a$		Notes	Default Values			Air <sup>1)</sup> Class
		cfm/person		l/s.person		cfm/ft <sup>2</sup>	l/s.m <sup>2</sup>		Occupant Density (see Note 4)  Persons per 1 000 ft <sup>2</sup> or per 100 m <sup>2</sup>	Combined Outdoor Air Rate (see Note 4)		
		cfm/person	l/s.person	cfm/person	l/s.person							
(1)	(2)	(3)	(4)	(5)	(6)	(7)	(8)	(9)	(10)	(11)		
g)	Health club/weight rooms	20	10	0.06	0.3		10	26	13.0	2		
h)	Bowling alley (seating)	10	5	0.12	0.6		40	13	6.5	1		
j)	Gambling casinos	7.5	3.8	0.18	0.9		120	9	4.6	1		
k)	Game arcades	7.5	3.8	0.18	0.9		20	17	8.3	1		
m)	Stages, studios	10	5	0.06	0.3	See Note 12	70	11	5.4	1		

<sup>1)</sup> Air Class Characteristic

- 1 Air with low contaminant concentration, low sensory-irritation intensity, and inoffensive odour.
- 2 Air with moderate contaminant concentration, mild sensory-irritation intensity, or mildly offensive odours. Class 2 air also includes air that is not necessarily harmful or objectionable but that is inappropriate for transfer or recirculation to spaces used for different purposes.
- 3 Air with significant contaminant concentration, significant sensory-irritation intensity, or offensive odour.
- 4 Air with highly objectionable fumes or gases or with potentially dangerous particles, bio aerosols, or gases, at concentrations high enough to be considered harmful.

NOTES

- 1 The rates in this table are based on all other applicable requirements being met.
- 2 This table applies to no-smoking areas only. Rates for smoking-permitted spaces shall be determined using other methods.
- 3 Volumetric airflow rates are based on an air density of 1.2 kg of dry air/m<sup>3</sup>, which corresponds to dry air at a barometric pressure of 1 atm (101.3 kPa) and an air temperature of 21°C. Rates may be adjusted for actual density but such adjustment is not required for compliance with this standard.



- 4** Actual occupant density should be considered, the default occupant density shall be used only when actual occupant density is not known. Default combined outdoor air (per person) rate is based on the default occupant density.
- 5** If the occupancy category for a proposed space or zone is not listed, the requirements for the listed occupancy category that is most similar in terms of occupant density, activities and building construction shall be used.
- 6** For high school and college libraries, use values shown for public assembly spaces- libraries.
- 7** The prescribed value may not be sufficient when stored materials include those having potentially harmful emissions.
- 8** Default occupancy for dwelling units shall be two persons for studio and one-bedroom units, with one additional person for each additional bedroom.
- 9** Air from one residential dwelling shall not be recirculated or transferred to any other space outside of that dwelling.
- 10** When combustion equipment is intended to be used on the playing surface, additional dilution ventilation and/or source control shall be provided.
- 11** The prescribed value does not allow for humidity control. Additional ventilation or dehumidification may be required to remove moisture.  
The prescribed value does not include special exhaust for stage effects, for example, dry ice vapours, smoke.

**Table 13 Outdoor Air Requirements for Ventilation of Health Care Facilities**  
(Clause 5.2.5)

SI No.	Application	Estimated Maximum Occupancy <sup>1)</sup> Persons/100 m <sup>2</sup>	Outdoor Air Requirements		Remarks
			l/s per Person	l/s per m <sup>2</sup>	
(1)	(2)	(3)	(4)	(5)	(6)
i)	Patient rooms	10	13	-	Special requirements and pressure relationships may determine minimum ventilation rates and filter efficiency. Procedures generating contaminants may require higher rates.
ii)	Medical procedure	20	8	-	
iii)	Operating rooms	20	15	-	
iv)	Recovery and ICU	20	8	-	
v)	Autopsy rooms	20	-	2.5	Air shall not be recirculated into other spaces.
vi)	Physical therapy	20	8	-	

<sup>1)</sup> Net occupiable space.

**5.2.3.2** There will be a limit of heat tolerance when air temperatures are excessive and the degree of physical activity is high. This limit is determined when the bodily heat balance is upset, that is, when the bodily heat gain due to conduction, convection and the radiation from the surroundings exceeds the bodily heat loss, which is mostly by evaporation of sweat from the surface of the body. The limits of heat tolerance for Indian workers are based on the study conducted by the Chief Adviser Factories, Government of India, Ministry of Labour and are given in his report on Thermal Stress in Textile Industry (Report No. 17) issued in 1956. According to this Report, where workers in industrial buildings wearing light clothing are expected to do work of moderate severity with the energy expenditure in the range 273 to 284 W, the maximum wet bulb temperature shall not exceed 29 °C and adequate air movement subject to a minimum air velocity of 30 m/min shall be provided, and in relation to the dry bulb temperature, the wet bulb temperature of air in the work room, as far as practicable, shall not exceed that given in Table 14.

**Table 14 Maximum Permissible Wet Bulb Temperatures for  
Given Dry Bulb Temperatures**  
(Clause 5.2.3.2)

SI No.	Dry Bulb Temperature °C	Maximum Wet-Bulb Temperature °C
(1)	(2)	(3)
i)	30	29.0
ii)	35	28.5
iii)	40	28.0
iv)	45	27.5
v)	50	27.0

NOTES

- 1 These are limits beyond which the industry should not allow the thermal conditions to go for more than 1h continuously. The limits are based on a series of studies conducted on Indian subjects in psychrometric chamber and on other data on heat casualties in earlier studies conducted in Kolar Gold Fields and elsewhere.
- 2 Figures given in this table are not intended to convey that human efficiency at 50 °C will remain the same as at 30 °C, provided appropriate wet bulb temperatures are maintained. Efficiency decreases with rise in the dry bulb temperature as well, as much as possible. Long exposures to temperature of 50 °C dry bulb/27 °C wet bulb may prove dangerous.
- 3 Refrigeration or some other method of cooling is recommended in all cases where conditions would be worse than those shown in this table.

### **5.3 Methods of Ventilation**

General ventilation involves providing a building with relatively large quantities of outside air in order to improve general environment of the building. This may be achieved in one of the following ways:

- a) Natural supply and natural exhaust of air;
- b) Natural supply and mechanical exhaust of air;
- c) Mechanical supply and natural exhaust of air; and
- d) Mechanical supply and mechanical exhaust of air.

#### **5.3.1 Control of Heat**

Although it is recognized that general ventilation is one of the most effective methods of improving thermal environmental conditions in factories, in many situations, the application of ventilation should be preceded by and considered along with some of the following other methods of control. This would facilitate better design of buildings for general ventilation, either natural or mechanical or both, and also reduce their cost.

##### **5.3.1.1 Isolation**

Sometimes it is possible to locate heat producing equipment, such as furnaces in such a position as would expose only a small number of workers to hot environment. As far as practicable, such sources of heat in factories should be isolated.

In situations where relatively few people are exposed to severe heat stress and their activities are confined to limited areas as in the case of rolling mill operators and crane operators, it may be possible to enclose the work areas and provide spot cooling or supply conditioned air to such enclosures.

##### **5.3.1.2 Insulation**

A considerable portion of heat in many factories is due to the solar radiation falling on the roof surfaces, which, in turn, radiate heat inside the building. In such situations, insulations of the roof or providing a false ceiling or double roofing would be very effective in controlling heat. Some reduction can also be achieved by painting the roof in heat reflective shades.

Hot surfaces of equipment, such as pipes, vessels, etc, in the building should also be insulated to reduce their surface temperature.

##### **5.3.1.3 Substitution**

Sometimes, it is possible to substitute a hot process by a method that involves application of localized or more efficiently controlled method of heating. Examples include induction hardening instead of conventional heat treatment, cold riveting or spot welding instead of hot riveting, etc.

##### **5.3.1.4 Radiant shielding**

Hot surfaces, such as layers of molten metal emanate radiant heat, which can best be controlled by placing a shield having a highly reflecting surface between the source of heat

and the worker, so that a major portion of the heat falling on the shield is reflected back to the source. Surfaces such as of tin and aluminium have been used as materials for shields. The efficiency of the shield does not depend on its thickness, but on the reflectivity and emissivity of its surface. Care should be taken to see that the shield is not heated up by conduction and for this purpose adequate provision should be made for the free flow upwards of the heated air between the hot surface and the shield by leaving the necessary air space and providing opening at the top and the bottom of the sides.

### 5.3.2 Volume of Air Required

The volume of air required shall be calculated by using both the sensible heat and latent heat gain as the basis. The larger of the two values obtained should be used in actual practice.

In places without sufficient wind speeds and/or in buildings where effective cross ventilation is not possible due to the design of the interior, the indoor air may be exhausted by a fan, with outdoor air entering the building through the open windows.

#### 5.3.2.1 Volume of air required for removing sensible heat

When the amount of sensible heat given off by different sources, namely, the sun, the manufacturing processes, machinery, occupants and other sources, is known and a suitable value for the allowable temperature rise is assumed, the volume of outside air to be provided for removing the sensible heat may be calculated from:

$$Q_1 = \frac{2.9768 K_s}{t}$$

where

$Q_1$  = quantity of air, in m<sup>3</sup>/h;

$K_s$  = sensible heat gained, in W; and

$t$  = allowable temperature rise, in °C.

**5.3.2.2** Temperature rise refers mainly to the difference between the air temperatures at the outlet (roof exit) and at the inlet openings for outside air. As very little data exist on allowable temperature rise values for supply of outside air in summer months, the values given in Table 15 related to industrial buildings may be used for general guidance.

**Table 15 Allowable Temperature Rise Values**  
(Clause 5.3.2.2)

SI No.	Height of Outlet Opening m	Temperature Rise °C
(1)	(2)	(3)
i)	6	3 to 4.5
ii)	9	4.5 to 6.5
iii)	12	6.5 to 11

## NOTES

- 1 The conditions are limited to light or medium heavy manufacturing processes, freedom from radiant heat and inlet openings not more than 3 to 4.5 m above floor level.
  - 2 At the working zone between floor level and 1.5 m above floor level, the recommended maximum allowable temperature rise for air is 2 °C to 3 °C above the air temperature at the inlet openings.
- 

**5.3.2.3 Volume of air required for removing latent heat**

If the latent heat gained from the manufacturing processes and occupants is also known and a suitable value for the allowable rise in the vapour pressure is assumed:

$$Q_2 = \frac{4 \ 127.26 \ K_1}{h}$$

where

$Q_2$  = quantity of air, in m<sup>3</sup>/h;

$K_1$  = latent heat gained, in W; and

$h$  = allowable vapour pressure difference, in mm of mercury.

NOTE – In majority of the cases, the sensible heat gain will far exceed the latent heat gain, so that the amount of outside air to be drawn by ventilating equipment can be calculated in most cases on the basis of the equation given in **5.3.2.1**.

**5.3.2.4** Ventilation is also expressed as m<sup>3</sup>/h/m<sup>2</sup> of floor area. This relationship fails to evaluate the actual heat relief provided by a ventilation system, but it does give a relationship which is independent of building height. This is a more rational approach, because, with the same internal load, the same amount of ventilation air, properly applied to the work zone with adequate velocity, will provide the desired heat relief quite independently of the ceiling height of the space, with few exceptions. Ventilation rates of 30 to 60 m<sup>3</sup>/h/m<sup>2</sup> have been found to give good results in many plants.

**5.4 Natural Ventilation**

The rate of ventilation by natural means through windows or other openings depends on:

- a) direction and velocity of wind outside and sizes and disposition of openings (wind action), and
- b) convection effects arising from temperature of vapour pressure difference (or both) between inside and outside the room and the difference of height between the outlet and inlet openings (stack effect).

**5.4.1 Ventilation of Non-industrial Buildings**

Ventilation in non-industrial buildings due to stack effect, unless there is a significant internal load, could be neglected, except in cold regions, and wind action may be assumed to be predominant.

**5.4.1.1** In hot dry regions, the main problem in summer is to provide protection from sun's heat so as to keep the indoor temperature lower than those outside under the sun. For this purpose, windows and other openings are generally kept closed during day time and only minimum ventilation is provided for the control of odours or for removal of products of combustion.

**5.4.1.2** In warm humid regions, the problem in the design of non-industrial buildings is to provide free passage of air to keep the indoor temperature as near to those outside in the shade as possible, and for this purpose the buildings are oriented to face the direction of prevailing winds and windows and other openings are kept open on both windward and leeward sides.

**5.4.1.3** In winter months in cold regions, the windows and other openings are generally kept shut, particularly during night; and ventilation necessary for the control of odours and for the removal of products of combustion can be achieved either by stack action or by some infiltration of outside air due to wind action.

#### **5.4.2** *Ventilation of Industrial Buildings*

In providing natural ventilation of all industrial buildings having significant internal heat loads due to manufacturing process, proper consideration should be given to the size and distribution of windows and other inlet openings in relation to outlet openings so as to give, with due regard to orientation, prevailing winds, size and configuration of the building and manufacturing processes carried on, maximum possible control of thermal environment.

**5.4.2.1** In the case of industrial buildings wider than 30 m, the ventilation through windows may be augmented by roof ventilation.

#### **5.4.3** *Design Guidelines for Natural Ventilation*

##### **5.4.3.1** *By wind action*

- 1) A building need not necessarily be oriented perpendicular to the prevailing outdoor wind; it may be oriented at any convenient angle between 0° and 30° without losing any beneficial aspect of the breeze. If the prevailing wind is from East or West, building may be oriented at 45° to the incident wind so as to diminish the solar heat without much reduction in air motion indoors.
- 2) Inlet openings in the buildings should be well distributed and should be located on the windward side at a low level, and outlet openings should be located on the leeward side. Inlet and outlet openings at high levels may only clear the top air at that level without producing air movement at the level of occupancy.
- 3) Maximum air movement at a particular plane is achieved by keeping the sill height of the opening at 85 percent of the critical height (such as head level) for the following recommended levels of occupancy:
  - i) For sitting on chair 0.75 m
  - ii) For sitting on bed 0.60 m
  - iii) For sitting on floor 0.40 m

- 4) Inlet openings should not as far as possible be obstructed by adjoining buildings, trees, sign boards or other obstructions or by partitions inside in the path of air flow.
- 5) In rooms of normal size having identical windows on opposite walls the average indoor air speed increases rapidly by increasing the width of window up to two-third of the wall width; beyond that the increase is in much smaller proportion than the increase of the window width. The air motion in the working zone is maximum when window height is 1.1m. Further increase in window height promotes air motion at higher level of window, but does not contribute additional benefits as regards air motion in the occupancy zones in buildings.
- 6) Greatest flow per unit area of openings is obtained by using inlet and outlet openings of nearby equal areas at the same level.
- 7) For a total area of openings (inlet and outlet) of 20 percent to 30 percent of floor area, the average indoor wind velocity is around 30 percent of outdoor velocity. Further increase in window size increases the available velocity but not in the same proportion as shown in Fig. 6. In fact, even under most favourable conditions the maximum average indoor wind speed does not exceed 40 percent of outdoor velocity.

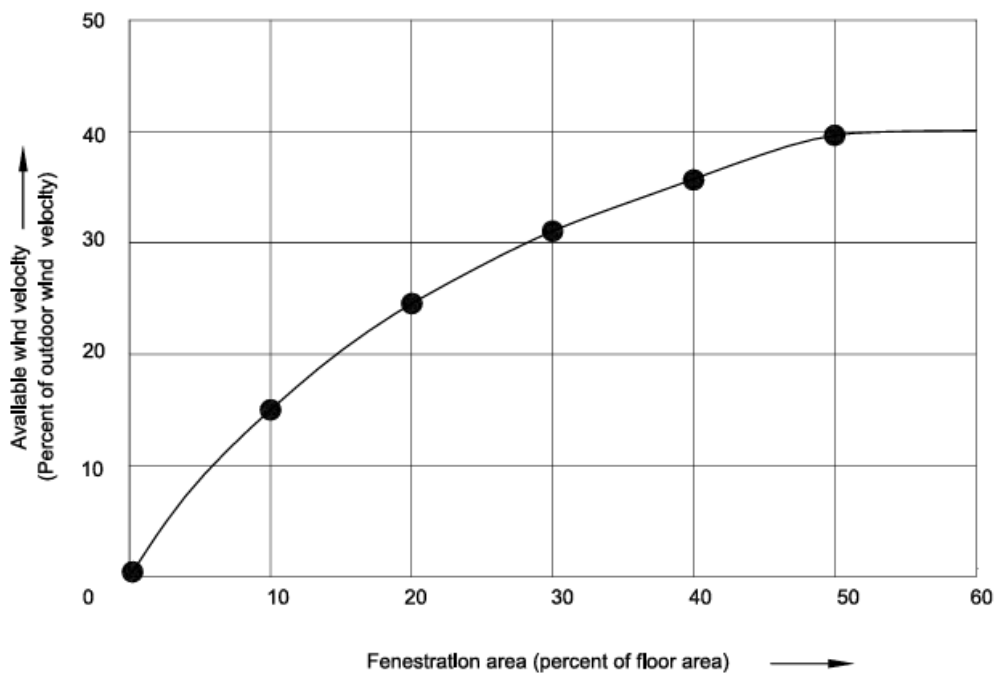

FIG. 6 EFFECT OF AREA OF OPENING ON AVERAGE INDOOR WIND VELOCITY

- 8) Where the direction of wind is quite constant and dependable, the size of the inlet should be kept within 30 to 50 percent of the total area of openings and the building should be oriented perpendicular to the incident wind. Where direction of the wind is quite variable the openings may be arranged so that as far as possible there is approximately equal area on all sides. Thus, no matter what the wind direction be, there would be some openings directly exposed to wind pressure and others to air suction and effective air movement through the building would be assured.
- 9) Windows of living rooms should open directly to an open space. In places where building sites are restricted, open space may have to be created in the buildings by providing adequate courtyards.



- 10) In the case of rooms with only one wall exposed to outside, provision of two windows on that wall is preferred to that of a single window.
- 11) Windows located diagonally opposite to each other with the windward window near the upstream corner give better performance than other window arrangements for most of the building orientations.
- 12) Horizontal louvers, that is, sunshades atop windows deflect the incident wind upward and reduce air motion in the zone of occupancy. A horizontal slot between the wall and horizontal louver prevents upward deflection of air in the interior of rooms. Provision of inverted L type ( $\Gamma$ ) louver increases the room air motion provided that the vertical projection does not obstruct the incident wind (see Fig. 7).
- 13) Provision of horizontal sashes inclined at an angle of  $45^\circ$  in appropriate direction helps to promote the indoor air motion. Sashes projecting outward are more effective than projecting inward.
- 14) Air motion at working plane 0.4 m above the floor can be enhanced by 30 percent using a pelmet type wind deflector (see Fig. 8).

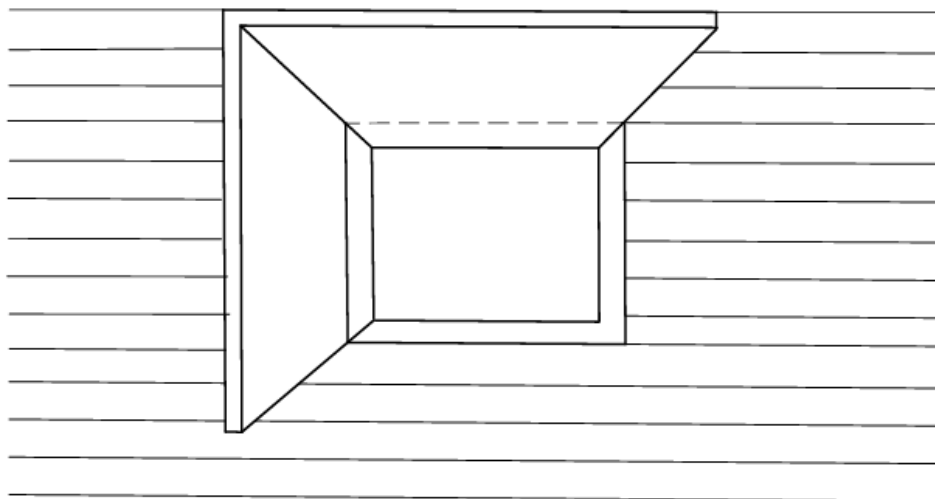

FIG. 7 L-TYPE LOUVER

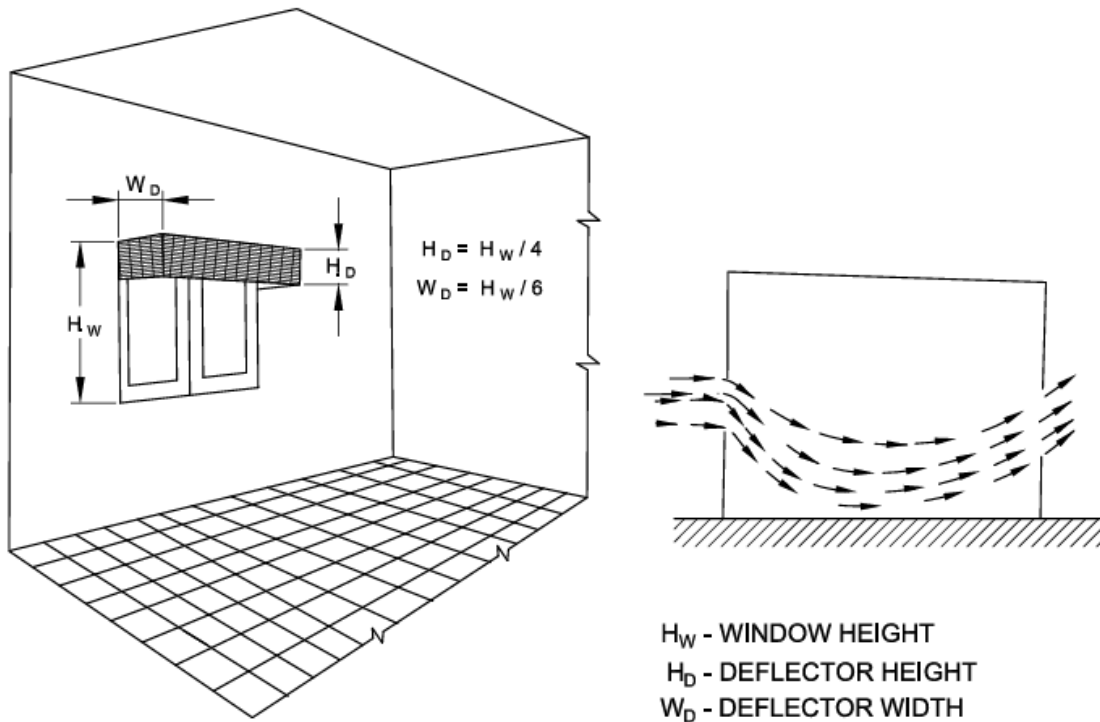

FIG. 8 SKETCH OF A PELMET TYPE WIND DEFLECTOR

- 15) Roof overhangs help promoting air motion in the working zone inside buildings.
- 16) In case of room with windows on one wall, with single window, the room wind velocity inside the room on the windward side is 10 percent of outdoor velocity at points up to a distance one-sixth of room width from the window and then decreases rapidly and hardly any air movement is produced in the leeward half portion of the room. The average indoor wind velocity is generally less than 10 percent of outdoor velocity. When two windows are provided and wind impinges obliquely on them, the inside velocity increases up to 15 percent of the outdoor velocity.
- 17) Cross ventilation can be obtained through one side of the building to the other, in case of narrow buildings with the width common in the multistoreyed type by the provision of large and suitably placed windows or combination of windows and wall ventilators for the inflow and outflow of air.
- 18) *Verandah* open on three sides is to be preferred since it causes an increase in the room air motion for most of the orientations of the building with respect to the outdoor wind.
- 19) A partition placed parallel to the incident wind has little influence on the pattern of the air flow, but when located perpendicular to the main flow, the same partition creates a wind shadow. Provision of a partition with spacing of 0.3 m underneath helps augmenting air motion near floor level in the leeward compartment of wide span buildings.
- 20) Air motion in a building unit having windows tangential to the incident wind is accelerated when another unit is located at end-on position on downstream side (see Fig. 9).

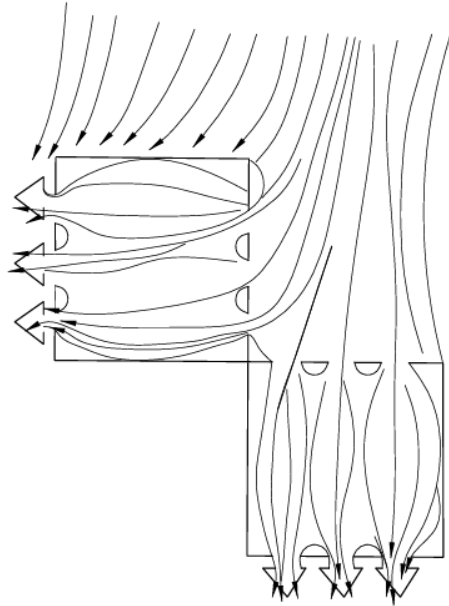

FIG. 9 TWO UNITS LOCATED AT THE END-ON POSITION

- 21) Air motion in two wings oriented parallel to the prevailing breeze is promoted by connecting them with a block on downstream side.
- 22) Air motion in a building is not affected by constructing another building of equal or smaller height on the leeward side; but it is slightly reduced if the leeward building is taller than the windward block.
- 23) Air motion in a shielded building is less than that in an unobstructed building. To minimize shielding effect, the distances between two rows should be  $8H$  for semi-detached houses and  $10H$  for long rows houses. However, for smaller spacing the shielding effect is also diminished by raising the height of the shielded building.
- 24) Hedges and shrubs deflect the air away from the inlet openings and cause a reduction in indoor air motion. These elements should not be planted at a distance of about  $8\text{ m}$  from the building because the induced air motion is reduced to minimum in that case. However, air motion in the leeward part of the building can be enhanced by planting a low hedge at a distance of  $2\text{ m}$  from the building.
- 25) Trees with large foliage mass having trunk bare of branches up to the top level of window, deflect the outdoor wind downwards and promotes air motion in the leeward portion of buildings,
- 26) Ventilation conditions indoors can be ameliorated by constructing buildings on earth mound having a slant surface with a slope of  $10^\circ$  on upstream side.
- 27) In case of industrial buildings, the window height should be about  $1.6\text{ m}$  and width about two-third of wall width. These should be located at a height of  $1.1\text{ m}$  above the floor. In addition to this, openings around  $0.9\text{ m}$  high should be provided over two-third length of the glazed area in the roof lights.
- 28) Height of industrial buildings, although determined by the requirements of industrial processes involved, generally kept large enough to protect the workers against hot stagnant air below the ceiling as also to dilute the concentration of contaminant inside. However, if high level openings in roof or walls are provided, building height can be reduced to  $4\text{ m}$  without in any way impairing the ventilation performance.
- 29) The maximum width up to which buildings of height usually found in factories, being effectively ventilated by natural means by wind action, is  $30\text{ m}$ , beyond which sufficient

reliance cannot be placed on prevailing winds. Approximately half the ventilating area of openings should be between floor level and a height of 2.25 m from the floor.

NOTE – For data on outdoor wind speeds at a place, reference may be made to 'The Climatic Data Handbook prepared by Central Building Research Institute, Roorkee, 1999'.

#### 5.4.3.2 By stack effect

Natural ventilation by stack effect occurs when air inside a building is at a different temperature than air outside. Thus, in heated buildings or in buildings wherein hot processes are carried on and in ordinary buildings during summer nights and during pre-monsoon periods, the inside temperature is higher than that of outside, cool outside air will tend to enter through openings at low level and warm air will tend to leave through openings at high level. It would, therefore, be advantageous to provide ventilators as close to ceilings as possible. Ventilators can also be provided in roofs as, for example, cowl, vent pipe, covered roof and ridge vent.

#### 5.4.4 Design Charts for Natural Ventilation

Openings for natural ventilation can be sized without the need for complex and expensive computer simulation methods using analytical techniques. This section presents four design charts (DCs) which can be used to assist in the sizing of ventilation openings to deliver natural ventilation.

The design charts are derived from analytical techniques (CIBSE, 2010). They provide either the geometrical free area ( $A_f$ ) of openings to deliver a recommended air flow rate, or the achieved flow rate for a given free area.

Based on information for inside-outside air temperature difference ( $\Delta T$ ), wind speed ( $U$ ) and wind pressure co-efficient ( $\Delta C_p$ ), the DCs are applicable for a wide range of weather conditions and parameters appropriate for residential buildings located in the selected Indian climatic zones.

These are considered to be the most common configurations encountered in practice in Indian residences. The corresponding DCs are

- a) DC-01 – Buoyancy-driven flow; single-sided ventilation with one opening (Fig. 10A and Fig. 11)
- b) DC-02 – Buoyancy-driven flow; cross-ventilation with multiple openings (Fig. 10B and Fig. 12)
- c) DC-03 – Wind-driven flow; single-sided ventilation with one opening (Fig. 10C and Fig. 13)
- d) DC-04 – Wind-driven flow; cross-ventilation with multiple openings (Fig. 10D and Fig. 14)

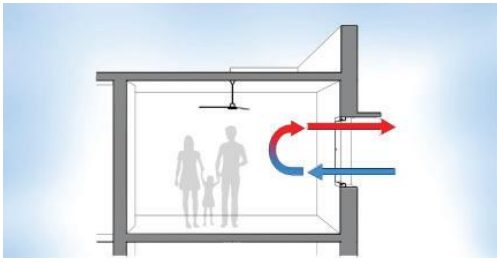

Fig. 10A DC-01

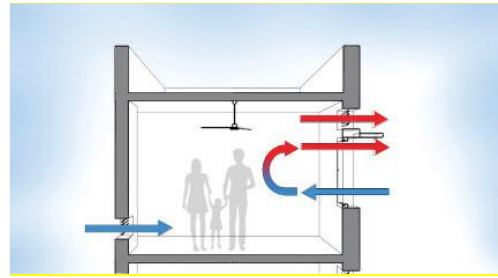

Fig. 10B DC-02

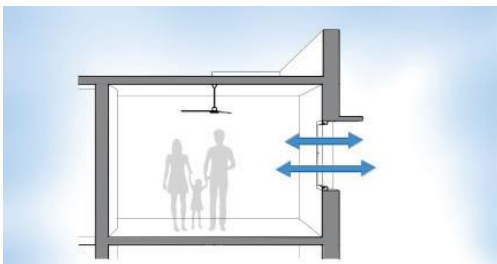

Fig. 10C DC-03

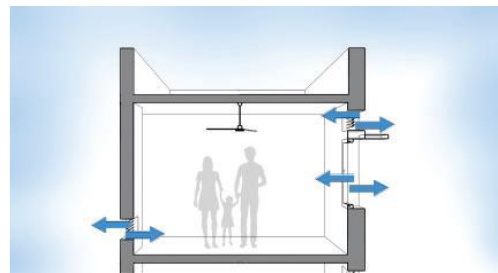

Fig. 10D DC-04

FIG. 10 CROSS-SECTION SKETCHES OF THE DRIVING FORCES FOR THE NATURAL VENTILATION SYSTEMS PRESENTED IN THE FOUR DESIGN CHARTS

#### 5.4.4.1 Design Charts for Natural Ventilation – By Stack Effect

a) DC-01 – Buoyancy-driven flow; single-sided ventilation with one opening

The DC-01 is derived from Equation 3 (CIBSE, 2010). For single openings the value for  $C_d$  adopted is 0.25.

$$A_f = \frac{q_{rec}}{C_d} \sqrt{\frac{(T_{inside} + 273)}{g h_a \Delta T_{inside-outside}}}$$

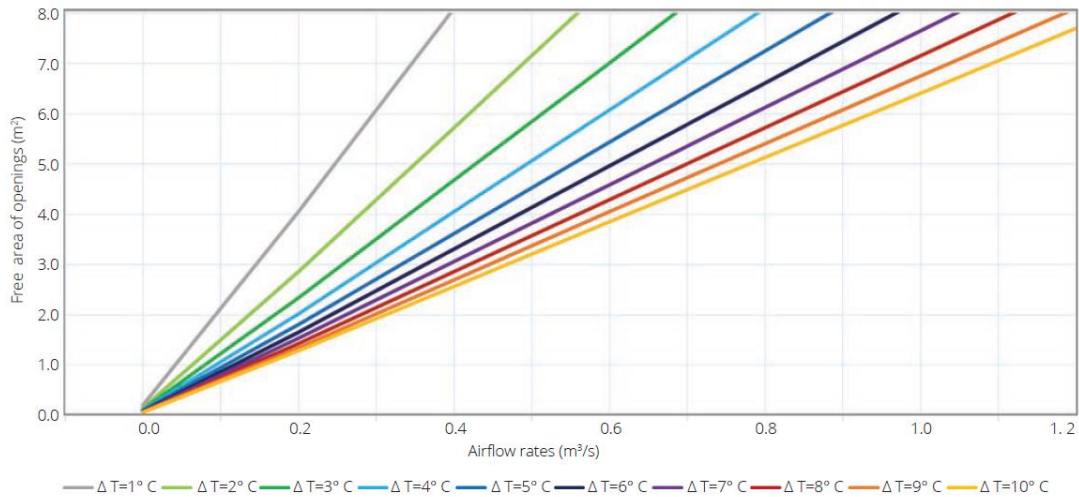
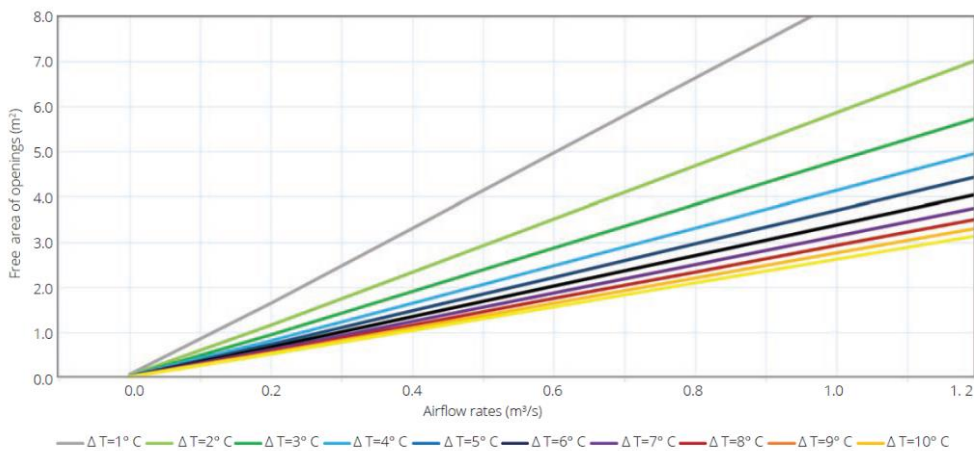

**FIG. 11 DESIGN CHART DC-01 FOR SINGLE-SIDED SINGLE OPENING BUOYANCY DRIVEN FLOW**

**b) DC-02 – buoyancy-driven flow; cross-ventilation**

The DC-02 is also derived from Equation 3 (CIBSE, 2010). Conversely, for multiple openings, the value for  $C_d$  adopted is 0.61

$$A_f = \frac{q_{rec}}{C_d} \sqrt{\frac{(T_{inside}+273)}{g h_a \Delta T_{inside-outside}}}$$



**FIG. 12 DESIGN CHART DC-02 FOR MULTIPLE OPENINGS AND BUOYANCY-DRIVEN FLOW**

**5.4.4.2 Design Charts for Natural Ventilation – By Wind Effect**

**a) DC-03 – Wind-driven flow; single-sided ventilation with one opening**

The DC-03 is derived from Equation 4 (CIBSE, 2010).

$$A_f = q_{rec} / C V_z$$

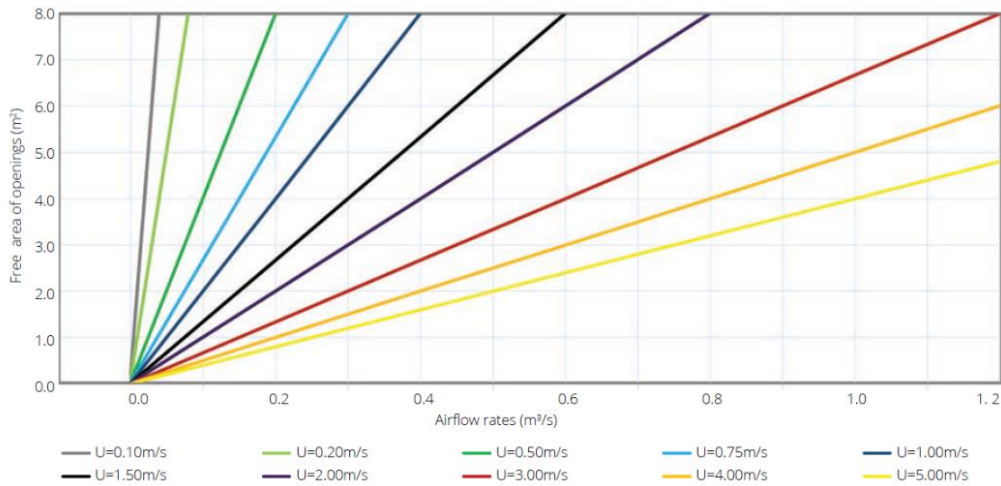

FIG. 13 DESIGN CHART DC-03 FOR SINGLE-SIDED SINGLE OPENINGS AND WIND-DRIVEN FLOW

b) DC-04— Wind-driven flow; cross-ventilation with multiple openings

The DC-4 is derived from Equation 6 (CIBSE, 2010). Pressure coefficients for orthogonal and oblique wind directions for the building shape used are from CIBSE Guide A (CIBSE, 2010).

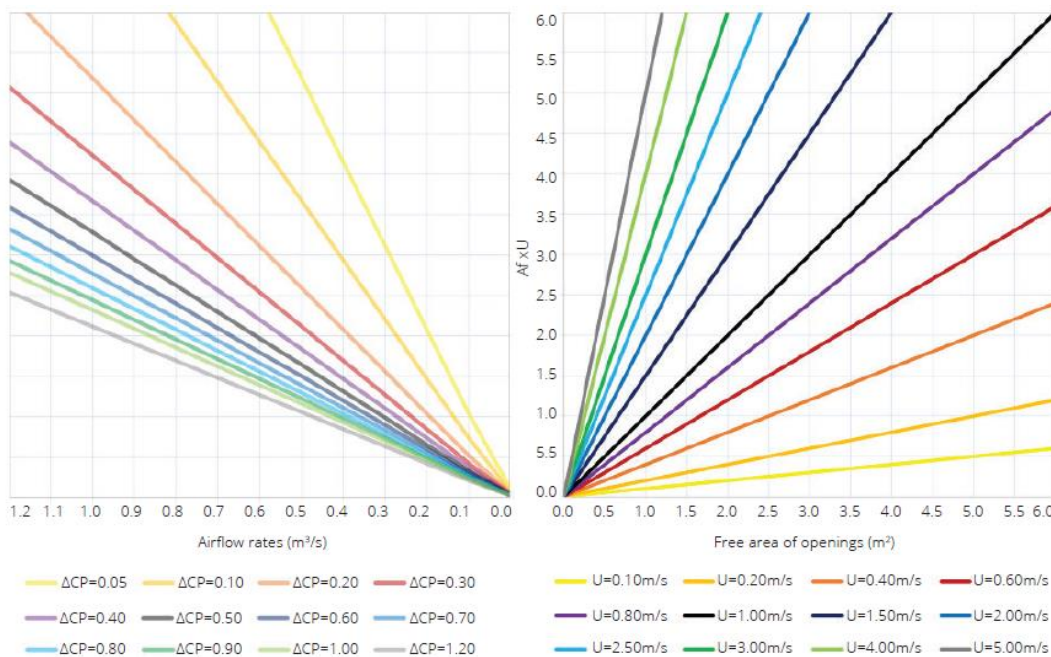

FIG. 14 DESIGN CHART DC-04 FOR MULTIPLE OPENINGS AND WIND-DRIVEN FLOW

5.5 Mechanical Ventilation

The requirements of mechanical ventilation shall be in accordance with Part 8 ‘Building services’, Section 3 ‘Air Conditioning, Heating and Mechanical Ventilation’ of the Code.

5.6 Determining Rate of Ventilation

5.6.1 Natural Ventilation

This is difficult to measure as it varies from time to time. The amount of outside air through windows and other openings depends on the direction and velocity of wind outside (wind action) and/or convection effects arising from temperature or vapour pressure differences (or both) between inside and outside of the building (stack effect).

#### 5.6.1.1 Wind action

For determining the rate of ventilation based on wind action the wind may be assumed to come from any direction within 45° of the direction of prevailing wind. Ventilation due to external wind is given by the following formula:

$$Q_w = K.A.V$$

where

$Q_w$  = rate of air flow, in m<sup>3</sup>/h;

$K$  = coefficient of effectiveness, which may be taken as 0.6 for wind perpendicular to openings and 0.3 for wind at an angle less than 45° to the openings;

$A$  = free area of inlet openings, in m<sup>2</sup>; and

$V$  = wind speed, in m/h.

NOTE – For wind data at a place, the local Meteorological Department may be consulted.

#### 5.6.1.2 Stack effect (thermal action)

Ventilation due to convection effects arising from temperature difference between inside and outside is given by:

$$Q_T = 7.0 A \sqrt{h(t_i - t_o)}$$

where

$Q_T$  = rate of air flow, in m<sup>3</sup>/h;

$A$  = free area of inlet openings, in m<sup>2</sup>;

$h$  = vertical distance between inlets and outlets, in m;

$t_i$  = average temperature of indoor air at height  $h$ , in °C; and

$t_o$  = temperature of outdoor air, in °C.

NOTE – The equation is based on 0.65 times the effectiveness of openings. This should be reduced to 0.50 if conditions are not favourable.

5.6.1.3 When areas of inlet and outlet openings are unequal, the value of  $A$  may be calculated using the equation:

$$\frac{2}{A^2} = \frac{1}{A_{\text{inlet}}^2} + \frac{1}{A_{\text{outlet}}^2}$$

#### 5.6.1.4 Combined Effect of Wind and Thermal Action



When both forces (wind and thermal) act together in the same direction, even without interference, the resulting air flow is not equal to the two flows estimated separately.

When acting simultaneously, the rate of air flow through the building may be computed by the following equation:

$$Q^2 = Q_w^2 + Q_t^2$$

where

- Q = resultant volume of air flow, in m<sup>3</sup>/min;
- Q<sub>w</sub> = volume of air flow due to wind force, in m<sup>3</sup>/min; and
- Q<sub>t</sub> = volume of air flow due to thermal force, in m<sup>3</sup>/min.

Wind velocity and direction, outdoor temperature, and indoor distribution cannot be predicted with certainty, and refinement in calculation is not justified. A simple method is to calculate the sum of the flows produced by each force separately. Then using the ratio of the flow produced by thermal forces to the aforementioned sum, the actual flow due to the combined forces can be approximated from Fig. 15. When the two flows are equal, the actual flow is about 30 percent greater than the flow caused by either force acting independently (see Fig. 15).

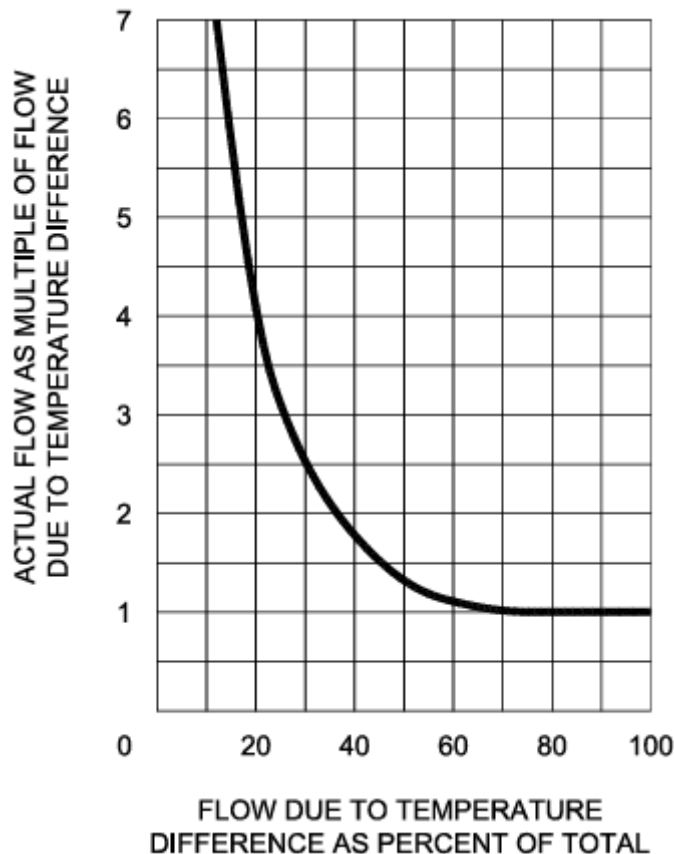

FIG. 15 DETERMINATION OF FLOW CAUSED BY COMBINED FORCES OF WIND AND TEMPERATURE DIFFERENCE

Judgment is necessary for proper location of openings in a building specially in the roof, where heat, smoke and fumes are to be removed. Usually, windward monitor openings should be closed, but if wind is so slight that temperature head can overcome it, all openings may be opened.

**5.6.1.5** For method for determining the rate of ventilation based on probable indoor wind speed with typical illustrative example for residential building, reference may be made to **A-4** of good practice [8-1(6)].

### **5.6.2 Mechanical Ventilation**

The determination of rate of ventilation in case of mechanical ventilation shall be done in accordance with Part 8 'Building Services', Section 3 'Air Conditioning, Heating and Mechanical Ventilation' of the Code.

### **5.6.3 Combined effect of Different Methods of Ventilation**

When combination of two or more methods of general ventilation is used, the total rate of ventilation shall be reckoned as the highest of the following three, and this rule shall be followed until an exact formula is established by research:

- a) 1.25 times the rate of natural ventilation,
- b) Rate of positive ventilation, and
- c) Rate of exhaust of air.

### **5.6.4 Measurement of Air Movement**

The rate of air movement of turbulent type at the working zone shall be measured either with a Kata thermometer (dry silvered type) or heated thermometer or properly calibrated thermocouple anemometer. Whereas anemometer gives the air velocity directly, the Kata thermometer and heated thermometer give cooling power of air and the rate of air movement is found by reference to a suitable nomogram using the ambient temperature.

## **5.7 Energy Conservation in Ventilation System**

**5.7.1** Maximum possible use should be made of wind induced natural ventilation. This may be accomplished by following the design guidelines given in **5.7.1.1**.

**5.7.1.1** Adequate number of circulating fans should be installed to serve all interior working areas during summer months in the hot dry and warm humid regions to provide necessary air movement at times when ventilation due to wind action alone does not afford sufficient relief.

**5.7.1.1.1** The capacity of a ceiling fan to meet the requirement of a room with the longer dimension  $D$  metre should be about  $55D$  m<sup>3</sup>/min.

**5.7.1.1.2** The height of fan blades above the floor should be  $(3H + W)/4$ , where  $H$  is the height of the room, and  $W$  is the height of work plane.

**5.7.1.1.3** The minimum distance between fan blades and the ceiling should be about 0.3 m.

**5.7.2** Electronic regulators should be used instead of resistance type regulators for controlling the speed of fans.

**5.7.3** When actual ventilated zone does not cover the entire room area, then optimum size of ceiling fan should be chosen based on the actual usable area of room, rather than the total floor area of the room. Thus, smaller size of fan can be employed and energy saving could be achieved.

**5.7.4** Power consumption by larger fans is obviously higher, but their power consumption per square metre of floor area is less and service value higher. Evidently, improper use of fans irrespective of the rooms' dimensions is likely to result in higher power consumption. From the point of view of energy consumption, the number of fans and the optimum sizes for rooms of different dimensions are given in Table 16.

**Table 16 Optimum Size/Number of Fans for Rooms of Different Sizes**  
(Clause 5.7.4)

Sl. No.	Room Width m	Optimum Size, mm/Number of Fans										
		4 m	5 m	6 m	7 m	8 m	9 m	10 m	11 m	12 m	14 m	16 m
(1)	(2)	(3)	(4)	(5)	(6)	(7)	(8)	(9)	(10)	(11)	(12)	(13)
i)	3	1 200/1	1 400/1	1 500/1	1 050/2	1 200/2	1 400/2	1 400/2	1 400/2	1 200/3	1 400/3	1 400/3
ii)	4	1 200/1	1 400/1	1 200/2	1 200/2	1 200/2	1 400/2	1 400/2	1 500/2	1 200/3	1 400/3	1 500/3
iii)	5	1 400/1	1 400/1	1 400/2	1 400/2	1 400/2	1 400/2	1 400/2	1 500/2	1 400/3	1 400/3	1 500/3
iv)	6	1 200/2	1 400/2	900/4	1 050/4	1 200/4	1 400/4	1 400/4	1 500/4	1 200/6	1 400/6	1 500/6
v)	7	1 200/2	1 400/2	1 050/4	1 050/4	1 200/4	1 400/4	1 400/4	1 500/4	1 200/6	1 400/6	1 500/6
vi)	8	1 200/2	1 400/2	1 200/4	1 200/4	1 200/4	1 400/4	1 400/4	1 500/4	1 200/6	1 400/6	1 500/6
vii)	9	1 400/2	1 400/2	1 400/4	1 400/4	1 400/4	1 400/4	1 400/4	1 500/4	1 400/6	1 400/6	1 500/6
viii)	10	1 400/2	1 400/2	1 400/4	1 400/4	1 400/4	1 400/4	1 400/4	1 500/4	1 400/6	1 400/6	1 500/6
ix)	11	1 500/2	1 500/2	1 500/4	1 500/4	1 500/4	1 500/4	1 500/4	1 500/4	1 500/6	1 500/6	1 500/6
x)	12	1 200/3	1 400/3	1 200/6	1 200/6	1 200/6	1 400/6	1 400/6	1 500/6	1 200/7	1 400/9	1 400/9
xi)	13	1 400/3	1 400/3	1 200/6	1 200/6	1 200/6	1 400/6	1 400/6	1 500/6	1 400/9	1 400/9	1 500/9
xii)	14	1 400/3	1 400/3	1 400/6	1 400/6	1 400/6	1 400/6	1 400/6	1 500/6	1 400/9	1 400/9	1 500/9

### 5.7.5 Acceptable Air Temperature with the Increase in the Air Speed

Potential to extend hours of natural ventilation. The natural ventilation (NV)- mixed mode (MM) solutions combine designed openings for natural ventilation with the simultaneous use of mechanical ceiling fans to deliver thermal comfort with minimal use of energy. The air movement induced by the fan allows a rise in the acceptable operative temperature which is proportional to the increase in the air speed. This combination will be referred to as NV-MM solutions for 'enhanced natural ventilation (NV+).

The total number of hours of the year for which the outdoor conditions are feasible for natural ventilation, calculated as per the adaptive thermal comfort model for India-Mixed Mode building, and estimated with the NV-MM solutions for NV+, are shown in Fig. 16 for each of the eight Indian cities. This estimation utilizes the values for the corresponding rise in the acceptable air temperature with the increase in the air speed shown in Table 17 for the scenario with  $T_{radiant} = T_{air}$  (as per special publication) and applies to clothing insulation values ranging from 0.50 clo to 0.70 clo and to metabolic rates ranging from 1.00 m to 1.30 m.

NOTE – Special publication may be ASHRAE 2010.

This scenario is considered likely to occur in a typical residential environment during daytime and in summer season, with NV operating and without any mechanical cooling source (a radiant cooling panel). This scenario yields more conservative values than the scenario for when occupants have some control over the local environment (as per special publication). Hours with mechanical cooling.

NOTE – Special publication may be ASHRAE 2017.

**Table 17 Corresponding Rise in the Acceptable Air Temperature with the Increase in the Air Speed (Clause 5.7.5)**

Sl. No.	Fan Speed Mode	Air Speed m/s	Corresponding Rise in Temperature °C		
			As Per ASHRAE 55-2010 Applying: 0.50 clo to 0.70 clo; 1.00 met to 1.30 met		As Per ASHRAE 55-2017 Applying:
			Tr-Ta=-10	Tr-Ta=0	0.50 clo to 1.00 clo; 1.10 met
			(4)	(5)	(6)
(1)	(2)	(3)	(4)	(5)	(6)
i)	off	0.1	-	-	-
ii)	I	0.6	1.20	2.00	2.80
iii)	II	0.9	1.80	2.70	3.40
iv)	III	1.2	2.20	3.30	3.75
v)	IV	1.5	2.50	3.60	4.00

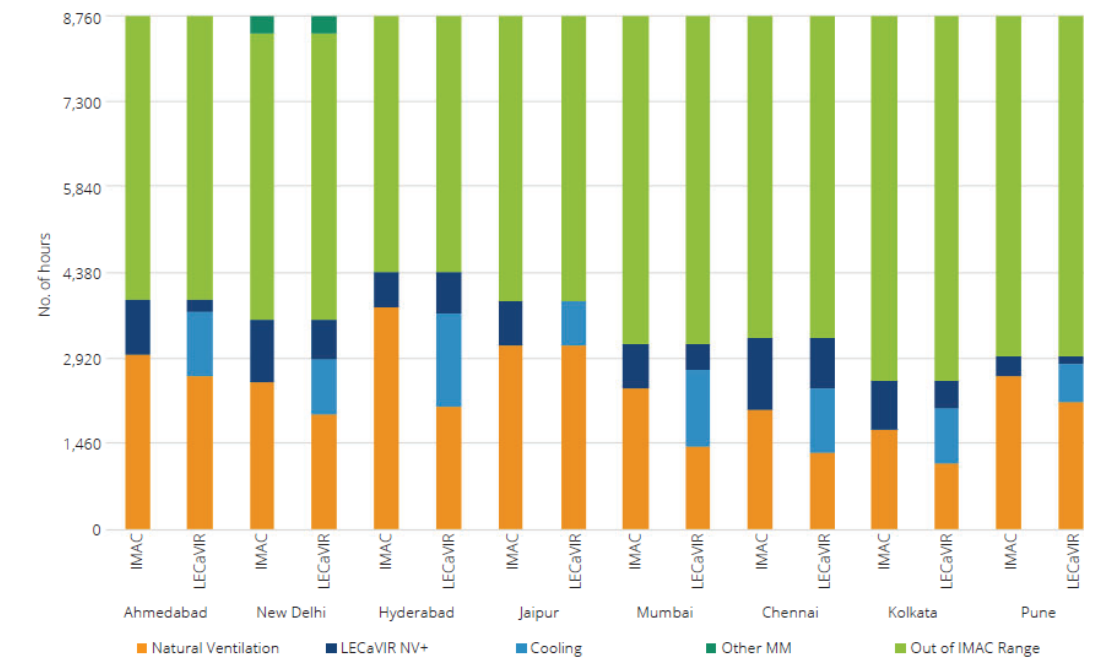

**FIG. 16 NUMBER OF HOURS IN A YEAR USING 'NATURAL VENTILATION, MECHANICAL COOLING AND OTHER MM', FROM THE adaptive thermal comfort model for India-Mixed Mode buildings , AND**

**USING 'NATURAL VENTILATION, ENHANCED NATURAL VENTILATION (NV+), MECHANICAL COOLING AND OTHER MM', FROM NV-MM SOLUTIONS FOR NV+ FOR EIGHT INDIAN CITIES****5.7.6 Mixed- Mode Principles**

Buildings that are designed with a mixed-mode ventilation strategy rely on natural ventilation for much of the occupied hours but also have integrated mechanical ventilation and cooling systems that are used in certain climatic or internal heat gain conditions. Mixed-mode (MM) systems include naturally ventilated buildings that are designed using one of the following approaches :

- a) Concurrent mixed-mode (see Fig. 17A) where both systems operate at the same space at the same time. The mechanical system operates as supplementary ventilation or cooling while the occupants are free to operate the windows based on their personal preference. This strategy is the most common form of mixed mode ventilation strategy typically employed for open-plan offices and residential buildings
- b) Change-over mixed-mode (see Fig. 17B) where the mechanical systems and natural ventilation operate in the same space at different times of the day or year. This approach requires an automated control system to determine which mode should be used at a particular point in time. The selection is based on a variety of input parameters such as outdoor conditions and occupancy. The system operating as change-over MM in a residence can either run automatically or inform the occupants to open or close the windows and switch on/off HVAC systems.
- c) Zoned mixed-mode (see Fig. 17C) where the mechanical cooling and natural ventilation operate at the same time but in different spaces of the building. This ventilation strategy is suitable for large office buildings where some offices could use natural ventilation by operating the windows whereas other rooms such as conference rooms may require a mechanical system for fresh air distribution.

Mixed-mode ventilation presents an energy efficient alternative to full air conditioning by capitalizing on the potential for natural ventilation when conditions permit.

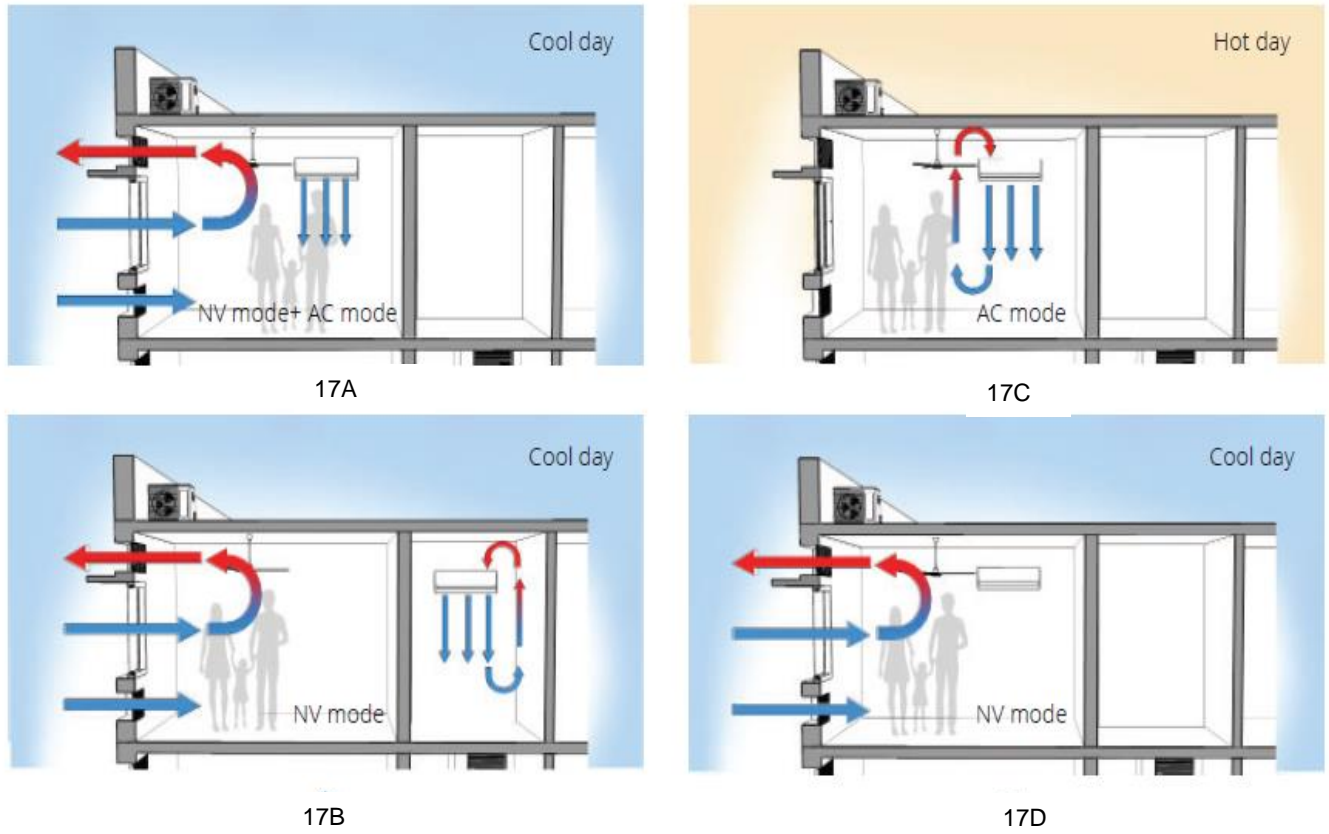

FIG. 17 CLASSIFICATION OF MIXED-MODE SYSTEMS. CONCURRENT MIXED-MODE SYSTEM (A); CHANGE-OVER MIXED-MODE SYSTEM (B); AND ZONED MIXED-MODE SYSTEM FOR COOL DAY (C) AND FOR HOT DAY (D)

**ANNEX A**  
(Clause 3.4.1)

**METHOD OF CALCULATING SOLAR LOAD ON VERTICAL SURFACES OF  
DIFFERENT ORIENTATION**

**A-1 DETAILS OF CALCULATION**

**A-1.1** The solar energy above the earth's atmosphere is constant and the amount incident on unit area normal to sun's rays is called solar constant ( $1.3608 \text{ kWm}^{-2}$  or  $2 \text{ cal/cm}^2/\text{min}$ ). This energy, in reaching the earth's surface, is depleted in, the atmosphere due to scattering by air molecules, water vapour, dust particles, and absorption by water vapour and ozone. The depletion varies with varying atmospheric conditions. Another important cause of depletion is the length of path traversed by sun's rays through the atmosphere. This path is the shortest when sun is at the zenith and, as the altitude of the sun decreases, the length of path in the atmosphere increases. Figure 18 gives the computed incident solar energy/hour on unit surface area normal to the rays under standard atmospheric conditions (see Note below) for different altitudes of the sun.

NOTE — The standard atmospheric conditions assumed for this computation are: cloud-free, 300 dust particles per  $\text{cm}^3$ , 15 mm of precipitable water, 2.5 mm of ozone, at sea level.

**A-1.2** In order to calculate the solar energy on any surface other than normal to the rays, the altitude of the sun at that time should be known. The corresponding value of direct solar radiation ( $I_N$ ) should then be found with the help of Fig. 19. The solar radiation incident on any surface ( $I_S$ ) is given by:

$$I_S = I_N (\sin \beta \sin \phi + \cos \beta \cos \alpha \cos \phi)$$

where

$\beta$  = solar altitude,

$\phi$  = angle tilt of the surface from the vertical (see Fig.12), and

$\alpha$  = wall solar azimuth angle.

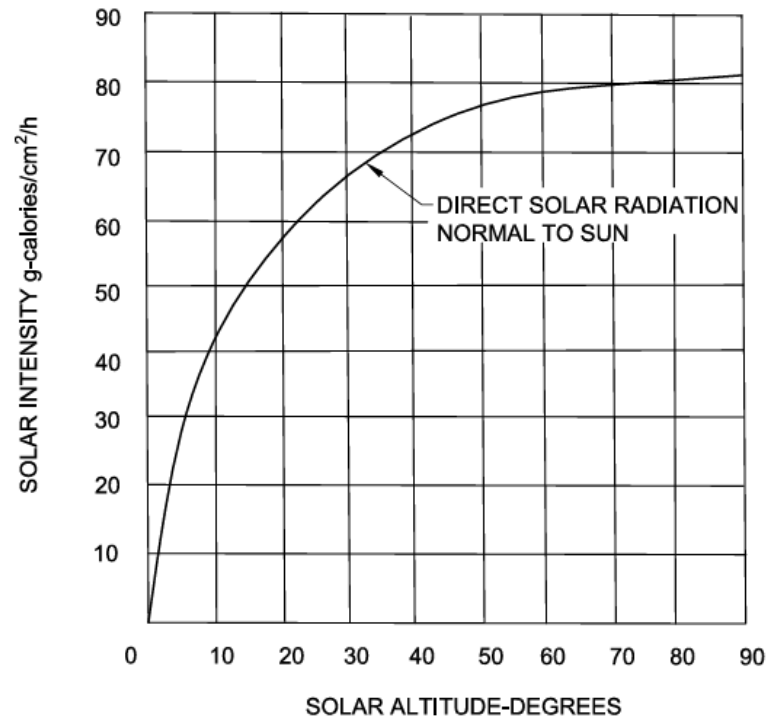

FIG. 18 DIRECT SOLAR INTENSITIES NORMAL TO SUN AT SEA LEVEL FOR STANDARD CONDITION (COMPUTED)

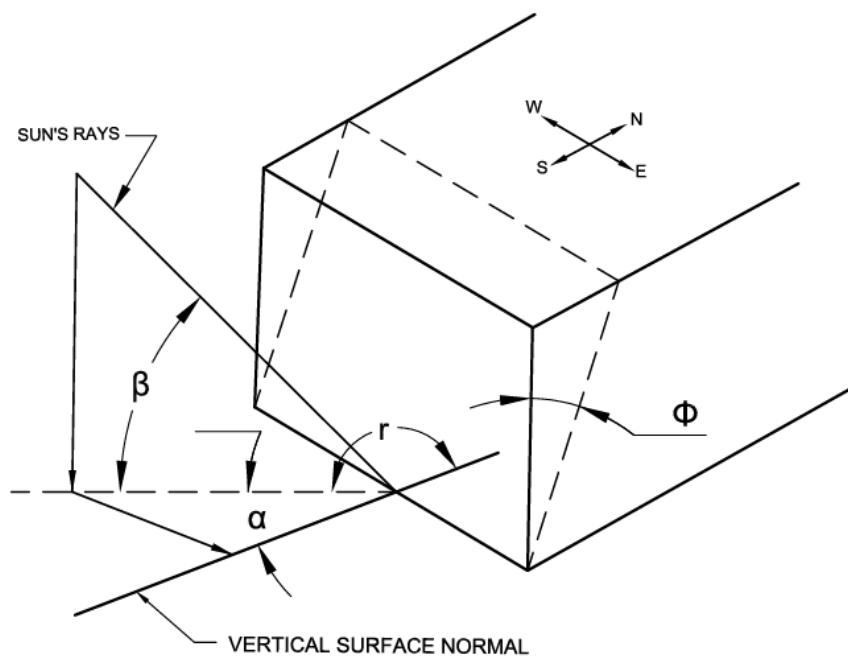

FIG. 19 DEFINITION OF SOLAR ANGLES



## **A-2 EXAMPLE TO FIND OUT ORIENTATION ON THE BASIS OF SOLAR LOAD**

### **A-2.1 Example**

**A-2.1.1** As an example, a simple building with flat roof, 10 m x 20 m, and 4 m high is dealt with below. For the sake of generalization, no shading device or verandah is taken.

**A-2.1.2** As the roof is horizontal, it will receive the same solar heat in any orientation.

**A-2.1.3** The area of the vertical surfaces are 4 m x 10 m = A (say) and 4 m x 20 m = 2A. Since, the external wall surface are not in shade except when the sun is not shining on them, the total solar load in a day on a surface can be obtained by multiplying the total load per unit area per day (see Table 3) by the area of the surface. For four principal orientations of the building, the total solar load on the building is worked out in Table 18.

**A-2.1.4** From Table 18, it can be seen that for the above type of building, orientation 3 (longer surface facing North and South) is appropriate as it affords maximum solar heat gain in winter and in summer. This is true for all places of India from the point of solar heat gain. By further increasing the length to breadth ratio, the advantage of this orientation will be more pronounced. It may also be noted that in higher altitudes, the relative merit of this orientation is more.

**A-2.1.5** It is also seen that the total solar heat on the building is the same for orientation 2 and 4. But if the site considerations require a choice between these two, orientation 2 should be preferred at places north of latitude 23°N and orientation 4 at southern places. This is so because the total solar load per unit area in summer on the north western wall decreases with the increase in latitude and that on the south western wall increases. It would, therefore, be advantageous to face only smaller surface of the building to greater solar load in the summer afternoons, when the air temperature also is higher.

**A-2.1.6** At hill stations, winter season cause more discomfort and so sole criterion for optimum orientation should be based on receiving maximum solar energy on building in winter.

**Table 18 Solar Heat Gained Due to Orientation of Buildings**  
(Clause A-2.1.3)

		8° N THIRUVANANTHAPURAM		13° N CHENNAI	
		May 16	Dec 22	May 16	Dec 22
1.	North	2 177 X A = 2 177A	–	1 625 X A = 1 625A	–
	East	2 618 X 2A = 5 236A	2 177 X 2A = 4 354A	2 697 X 2A = 5 394A	2 019 X 2A = 4 038A
	South	–	4 164 X A = 4 164A	–	4 385 X A = 4 385A
	West	2 618 X 2A = 5 236A	2 177 X 2A = 4 354A	2 697 X 2A = 5 394A	2 019 X 2A = 4 038A
	<b>Total</b>	12 649A	12 872A	12 413A	12 461A
2.	NE	2 650 X A = 2 650A	410 X A = 410A	2 492 X A = 2 492A	315 X A = 315A
	SE	1 167 X 2A = 2 334A	3 391 X 2A = 6 782A	1 341 X 2A = 2 682A	3 423 X 2A = 6 846A
	SW	1 167 X 2A = 2 334A	3 391 X A = 3 391A	1 341 X A = 1 341A	3 423 X A = 3 423A
	NW	2 650 X 2A = 5 300A	410 X 2A = 820A	2 492 X A = 4 984A	315 X 2A = 630A
	<b>Total</b>	12 618A	11 403A	11 499A	11 214A
3.	North	2 177 X 2A = 4 354A	–	1 625 X 2A = 3 250A	–
	East	2 618 X A = 2 618A	2 177 X A = 2 177A	2 697 X A = 2 697A	2 019 X A = 2 019A
	South	–	4 164 X 2A = 8 328A	–	4 385 X 2A = 8 770A
	West	2 618 X A = 2 618A	2 177 X A = 2 177A	2 697 X A = 2 697A	2 019 X A = 2 019A
	<b>Total</b>	9 590A	12 602A	8 644A	12 808A
4.	NE	2 650 X 2A = 5 300A	–	2 492 X A = 4 984A	315 X 2A = 630A
	SE	1 167 X A = 1 167A	2 177 X A = 2 177A	1 341 X A = 1 341A	3 423 X A = 3 423A
	SW	1 167 X 2A = 2 334A	4 164 X 2A = 8 328A	1 341 X 2A = 2 682A	3 423 X 2A = 6 846A
	NW	2 650 X A = 2 650A	2 177 X A = 2 177A	2 492 X A = 2 492A	315 X A = 315A
	<b>Total</b>	11 451A	12 682A	11 499A	11 214A
		19° N MUMBAI		23° N KOLKATA	
		May 16	Dec 22	May 16	Dec 22
1.	North	962 X A = 962A	–	741 X A = 741A	–
	East	2 795 X 2A = 5 590A	1 830 X 2A = 3 660A	2 871 X 2A = 5 742A	1 703 X 2A = 3 406A
	South	–	4 574 X A = 4 574A	205 X A = 205A	4 637 X A = 4 637A
	West	2 795 X 2A = 5 590A	1 830 X 2A = 3 660A	2 871 X 2A = 5 742A	1 703 X 2A = 3 406A
	<b>Total</b>	12 142A	11 894A	12 430A	11 449A
2.	NE	2 255 X A = 2 255A	237 X A = 237A	2 192 X A = 2 192A	173 X A = 173A
	SE	1 640 X 2A = 3 280A	3 438 X 2A = 6 876A	1 845 X 2A = 3 690A	3 454 X 2A = 6 908A
	SW	1 640 X A = 1 640A	3 438 X A = 3 438A	1 845 X A = 1 845A	3 454 X A = 3 454A
	NW	2 255 X 2A = 4 510A	237 X 2A = 474A	2 192 X 2A = 4 384A	173 X 2A = 346A
	<b>Total</b>	11 685A	11 025A	12 111A	10 881A
3.	North	962 X 2A = 1 924A	–	741 X 2A = 1 482A	–
	East	2 795 X A = 2 795A	1 830 X A = 1 830A	2 871 X A = 2 871A	1 703 X A = 1 703A
	South	–	4 574 X 2A = 9 148A	205 X 2A = 410A	4 637 X 2A = 9 274A
	West	2 795 X A = 2 795A	1 830 X A = 1 830A	2 871 X A = 2 871A	1 703 X A = 1 703A
	<b>Total</b>	7 514A	12 808A	7 634A	12 680A
4.	NE	2 255 X 2A = 4 510A	237 X 2A = 474A	2 192 X 2A = 4 384A	173 X 2A = 346A
	SE	1 640 X A = 1 640A	3 438 X A = 3 438A	1 845 X A = 1 845A	3 454 X A = 3 454A
	SW	1 640 X 2A = 3 280A	3 438 X 2A = 6 876A	1 845 X 2A = 3 690A	3 454 X 2A = 6 908A
	NW	2 255 X A = 2 255A	237 X A = 237A	2 192 X A = 2 192A	173 X A = 173A
	<b>Total</b>	11 685A	11 025A	12 111A	10 881A

29° N DELHI

		May 16	Dec 22
1.	North	536 X A = 536A	-
	East	2 950 X 2A = 5 900A	1 467 X 2A = 2 934A
	South	741 X A = 741A	4 543 X A = 4 543A
	West	2 950 X 2A = 5 900A	1 467 X 2A = 2 934A
	<b>Total</b>	13 077A	10 411A

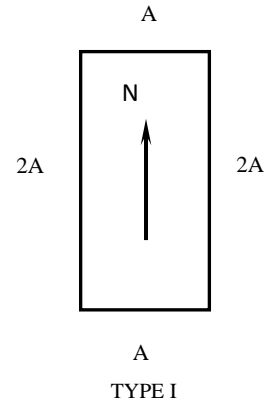

2.	NE	2 098 X A = 2 098A	110 X A = 110A
	SE	2 192 X 2A = 4 384A	3 265 X 2A = 6 530A
	SW	2 192 X A = 2 192A	3 265 X A = 3 265A
	NW	2 098 X 2A = 4 196A	110 X 2A = 220A
	<b>Total</b>	12 870A	10 125A

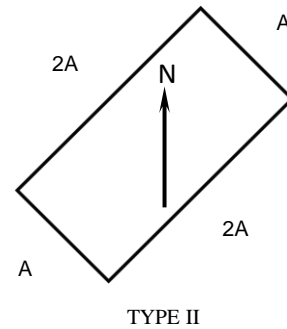

3.	North	536 X 2A = 1 072A	-
	East	2 950 X A = 2 950A	1 467 X A = 1 467A
	South	741 X 2A = 1 482A	4 543 X 2A = 9 086A
	West	2 950 X A = 2 950A	1 467 X A = 1 467A
	<b>Total</b>	8 454A	12 020A

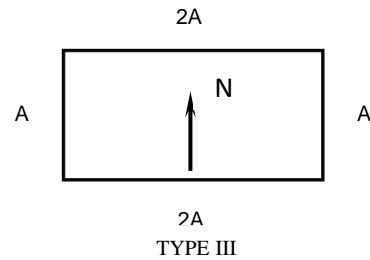

4.	NE	2 098 X 2A = 4 196A	110 X 2A = 220A
	SE	2 192 X A = 2 192A	3 265 X A = 3 265A
	SW	2 192 X 2A = 4 384A	3 265 X 2A = 6 530A
	NW	2 098 X A = 2 098A	110 X A = 110A
	<b>Total</b>	12 870A	10 125A

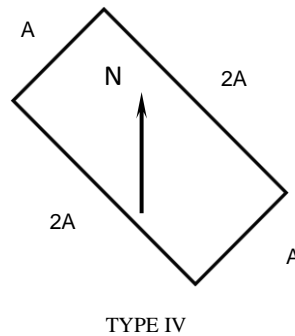

**ANNEX B**

(Clauses 4.2.5, 4.2.5.2, 4.2.5.4 and 4.2.6.1)

**SKY COMPONENT TABLES****B-1 Description of Tables****B-1.1** The three sky component tables are as given below:

- a) Table 19 – Percentage sky components on the horizontal plane due to a vertical rectangular opening for the clear design sky
- b) Table 20 – Percentage sky components on the vertical plane perpendicular to a vertical rectangular opening for the clear design sky
- c) Table 21 – Percentage sky components on the vertical plane parallel to a vertical rectangular opening for the clear design sky

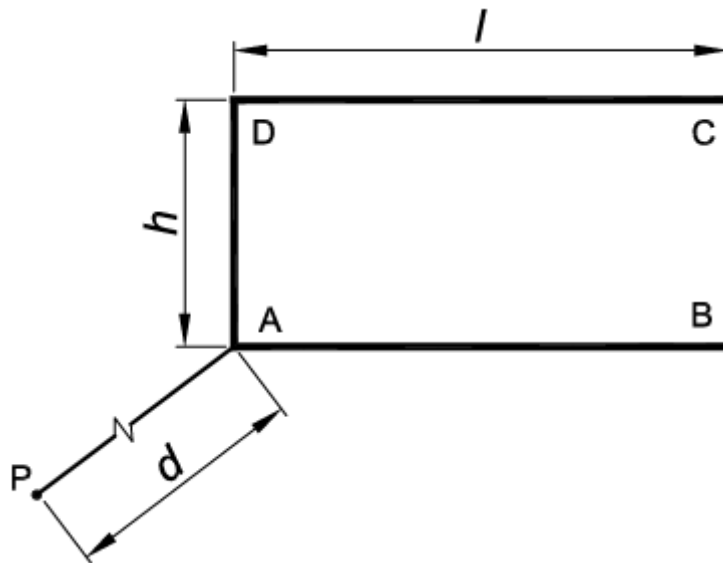
**B-1.2** All the tables are for an unglazed opening illuminated by the clear design sky.**B-1.3** The values tabulated are the components at a point  $P$  distant from the opening on a line perpendicular to the plane of the opening through one of its lower corners, and  $l$  and  $h$  are the width and height respectively of the rectangular opening (see Fig. 20).**FIG. 20 DEPICTION OF OBSERVATION POINT 'P' W.R.T. WINDOW OPENING****B-1.4** Sky component for different  $h/d$  and  $l/d$  values are tabulated, that is, for windows of different size and for different distances of the point  $P$  from the window.**B-1.5** By suitable combination of the values obtained from the three tables, for a given point for a given window, the sky component in any plane passing through the point may be obtained.

**B-1.6 Method of Using the Tables**

**B-1.6.1** Method of using the Tables to get the sky component at given point is explained with help of the following example.

**B-1.6.2 Example**

It is desired to calculate the sky component due to a vertical window ABCD with width 1.8 m and height 1.5 m at a point P on a horizontal plane 3.0 m from the window wall located as shown in the Fig. 21. Foot of the perpendicular N is 0.6 m below the sill and 0.9 m to the left of AD.

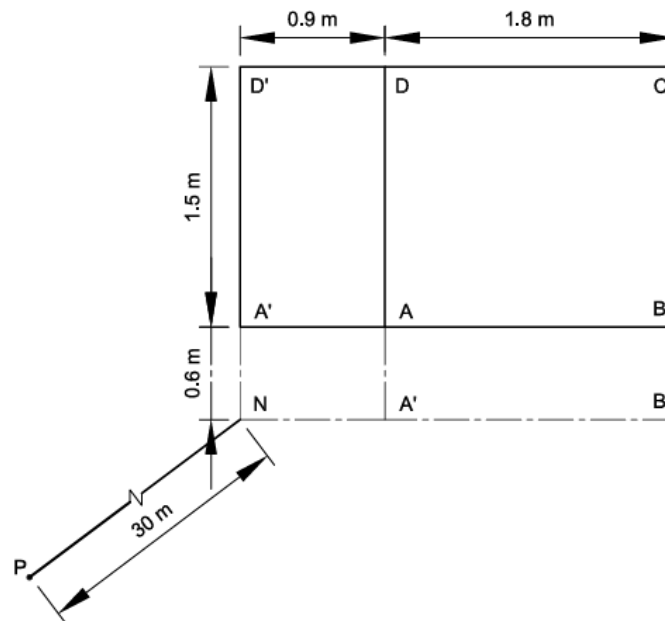

FIG. 21

Consider ABCD extended to NB'CD'

1) For NB'CD'

$$\begin{aligned} l/d &= (1.8+0.9)/3 = 0.9 \\ h/d &= (1.5+0.6)/3 = 0.7 \\ F_1 &= 5.708 \text{ per cent (from Table 19)} \end{aligned}$$

2) For NA'DD'

$$\begin{aligned} l/d &= 0.9/3 = 0.3 \\ h/d &= (1.5+0.6)/3 = 0.7 \\ F_2 &= 2.441 \text{ per cent (from Table 19)} \end{aligned}$$

3) For NB'BA'

$$l/d = (1.8+0.9)/3 = 0.9$$

$$h/d = 0.6/3 = 0.2$$

$$F_3 = 0.878 \text{ per cent (from Table 19)}$$

4) For NA'AA'

$$l/d = 0.9/3 = 0.3$$

$$h/d = 0.6/3 = 0.2$$

$$F_4 = 0.403 \text{ per cent (from Table 19)}$$

Since ABCD = NB'CD'-NA'DD'-NB'BA'+NA'AA'

$$\begin{aligned} \text{Sky Component, } F &= F_1 - F_2 - F_3 + F_4 \\ &= 5.708 - 2.441 - 0.878 + 0.403 \\ &= 2.792 \end{aligned}$$

## B-2 GENERAL INSTRUCTIONS

**B-2.1** For irregular obstructions like row of trees parallel to the plane of the window, equivalent straight boundaries horizontal and vertical, maybe drawn.

**B-2.2** Waldram diagrams are an effective early-stage design tool for planning daylight and direct solar illuminance. Figure 22 and Fig 23 show two possible massing schemes for a site located at 17°N latitude, while Fig 24 and Fig 25 illustrate the corresponding Waldram diagrams drawn from the central open area of the site. The white area above the shadow silhouettes in Fig 24 and Fig 25 represents visible sky, with 48 percent sky view in Fig 24 and 65 percent sky view in Fig 25. The yellow lines indicate the annual sun path as seen from the middle of the central open area of the site, aiding in evaluating sky visibility and optimizing site layouts for improved daylight performance.

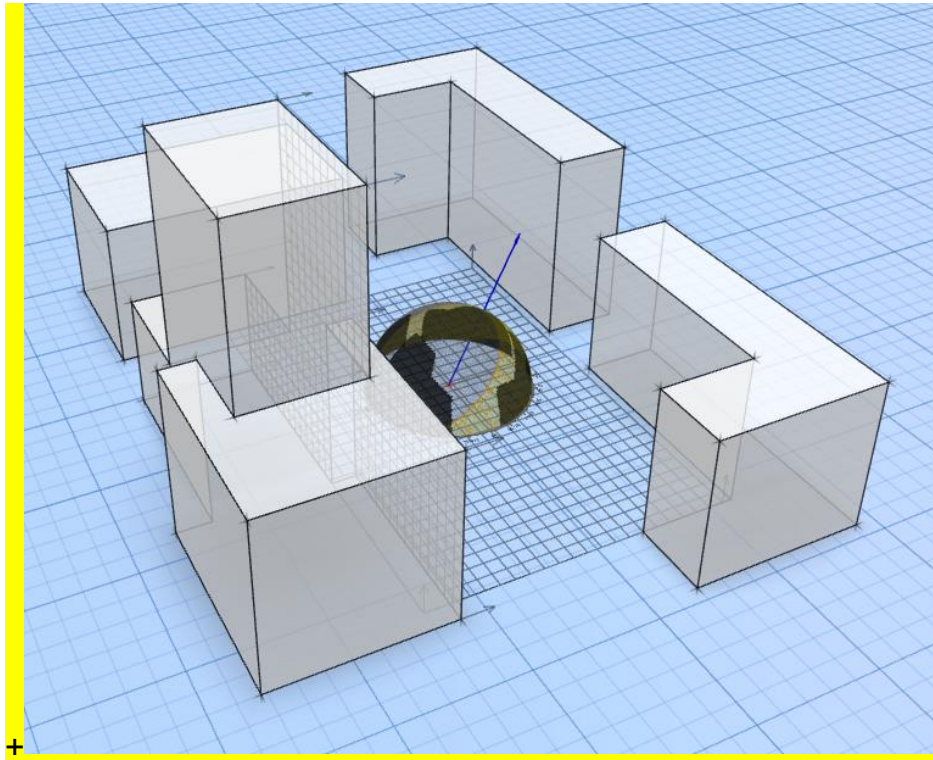

FIG. 22 MASSING SCHEME A

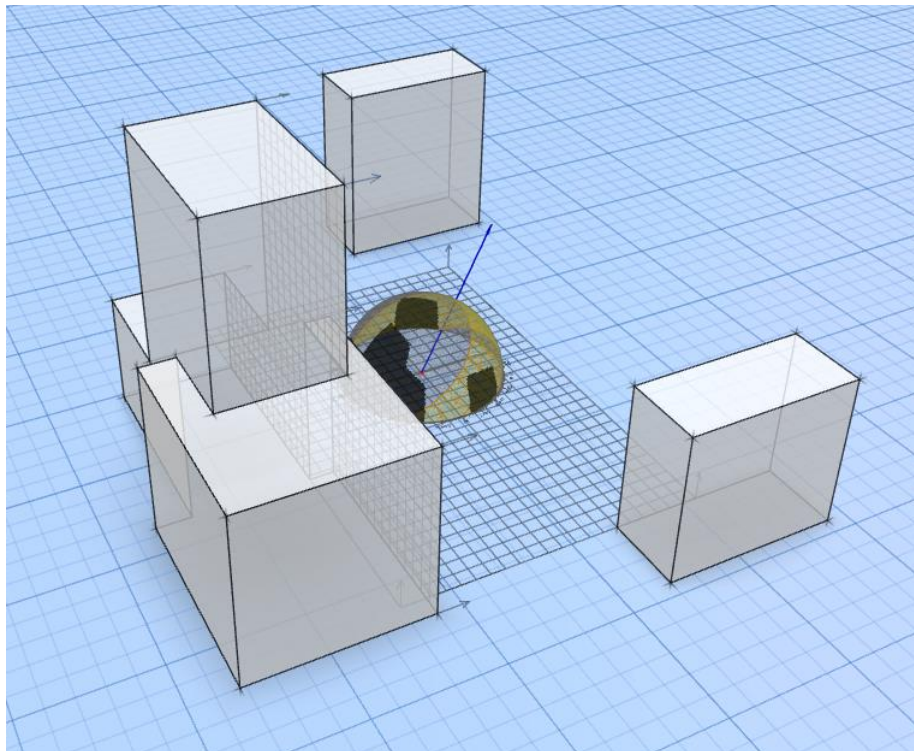

FIG. 23 MASSING SCHEME B

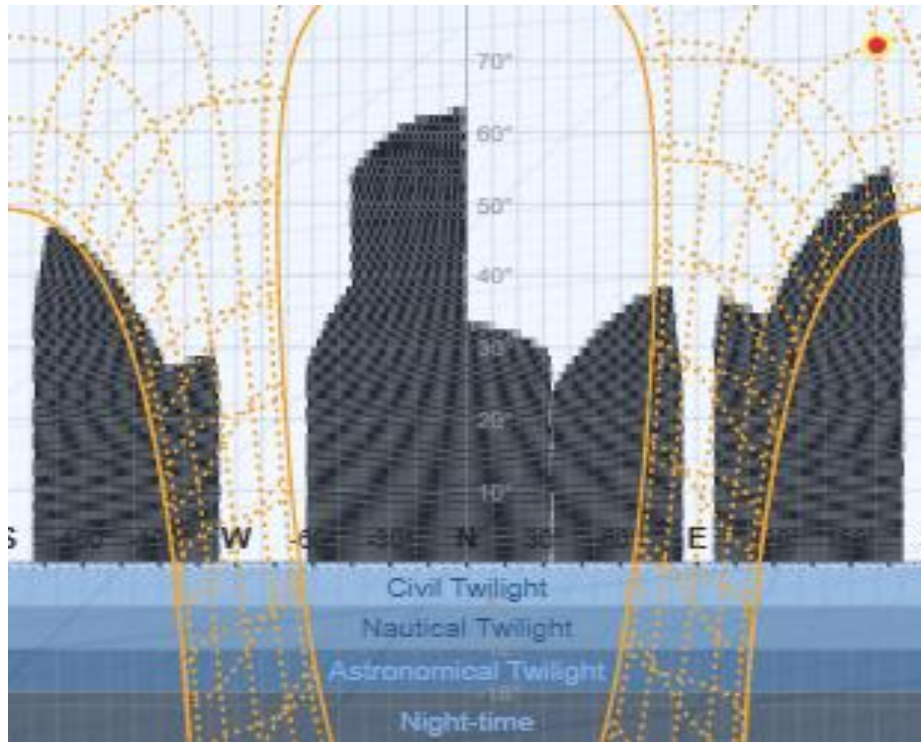

FIG. 24 WALDRAM DIAGRAM A

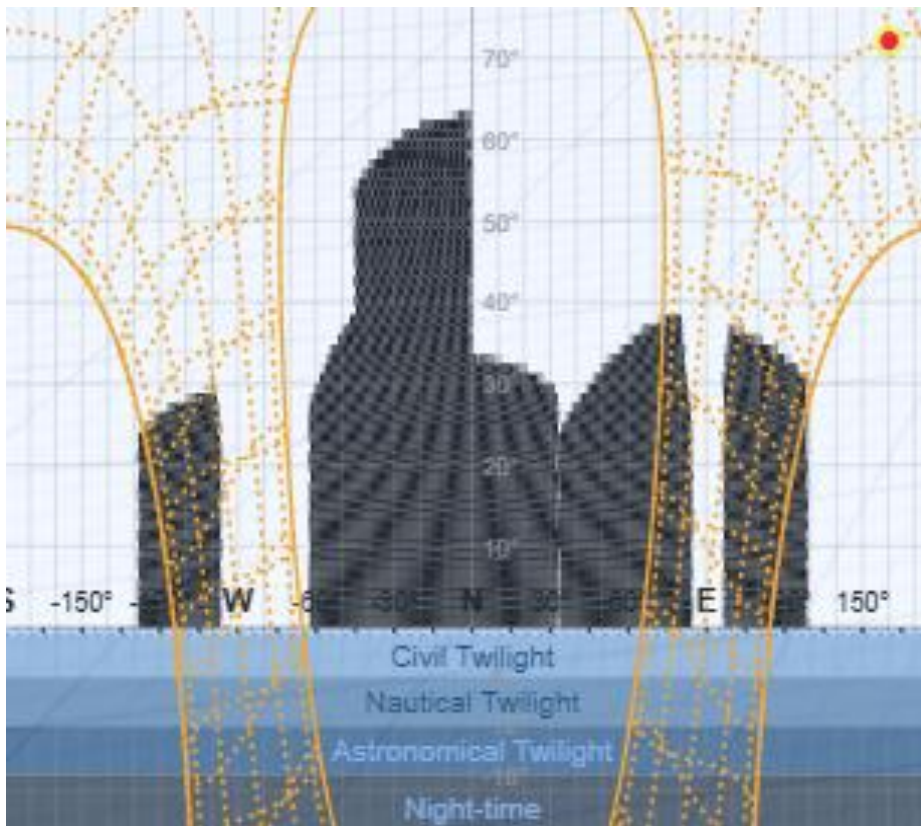

FIG. 25 WALDRAM DIAGRAM B



**B-2.3** For bay windows, dormer windows or corner windows the effective dimensions of window opening computed should be taken when using the tables to find the sky components.

### B-3 CALCULATION OF INTERNAL REFLECTED COMPONENT

**B-3.1** The internal reflected component (IRC) is a variable quantity which varies from point to point in a room depending upon the interior finish. IRC value is maximum at the centre of the room and decreases elsewhere in all directions. For processing calculations of IRC at any given point of the room, special techniques have to be made out. The internal reflected component may be calculated by using the formula:

$$IRC = \frac{0.85W}{A(1-R)} (CR_{fw} + 10R_{cw})$$

where

$W$  = window area;

$C$  = constant of value 78 when there is no external obstruction but it has different values as shown in the following table when there are obstructions;

$R_{fw}$  = average reflection factor of the floor and those parts of the wall below the plane of the mid-height of the window (excluding the window wall);

$R_{cw}$  = average reflection factor of the ceiling and those parts of the wall above the plane of the mid-height of the window (excluding the window wall);

$A$  = area of all the surfaces in the room (ceiling walls, floor and windows); and

$R$  = average reflection factor of all surfaces in the room (ceiling, walls, floor and windows) expressed as a decimal part of unity.

#### Values of C for Different Angle of Obstruction

(Clause B-3.1)

Angle of Obstruction, Degree (1)	Sky + External Obstruction, C (2)
5	68.9
15	50.6
25	36.2
35	26.7
45	20.1
55	15.8
65	12.9
75	11.1
85	10.36

**B-3.2 Example**

Consider two rooms of dimensions:

Room  $X = 6 \text{ m } (l) \times 5 \text{ m } (w) \times 3 \text{ m } (ht)$

Room  $Y = 3.7 \text{ m} \times 3 \text{ m} \times 3 \text{ m}$

Let the window area be 15 percent of the floor area and be glazed.

Window size in room  $X = 2.5 \text{ m} \times 1.8 \text{ m}$

Window size in room  $3.7 \text{ m} \times 3 \text{ m}$

The window are on the  $Y = 6 \text{ m} \times 3 \text{ m}$  side in room  $X$  and  $3.7 \text{ m} \times 3 \text{ m}$  side in room  $Y$ , and the sill heights are  $0.9 \text{ m}$  from floor level.

Reflection coefficients of:

walls and ceiling = 70 percent

floor = 20 percent

glazing = 15 percent

Value of IRC in room  $X$ :

a) Total interior area,  $A = 2(30 + 18 + 15) = 126 \text{ m}^2$

b) Average reflection factor of interior:

$$R = \frac{61.5 \times 0.7 + 30 \times 0.7 + 30 \times 0.2 + 4.5 \times 0.15}{61.5 + 30 + 30 + 4.5} = 0.56$$

c)  $1 - R = 0.44$

d) Mid-height of window is  $1.83 \text{ m}$  from floor, average reflection factor of room below  $1.83 \text{ m}$  level excluding the wall containing the window:

$$R_{fw} = \frac{29.28 \times 0.7 + 30 \times 0.2}{29.28 + 30} = 0.45$$

e) Average reflection factor of room above  $1.83 \text{ m}$  level excluding the wall containing the window:

$$R_{ew} = \frac{18.72 \times 0.7 + 30 \times 0.7}{18.72 + 30} = 0.7$$

f)  $IRC = \frac{0.85 \times 4.5}{126 \times 0.44} (78 \times 0.45 + 10 \times 0.7) = 2.904$

Value of IRC in room Y:

a) Total interior area:

$$A = 2(3.7 \times 3 + 3.7 \times 3 + 3 \times 3) = 62.4 \text{ m}^2$$

b) Average reflection factor:

$$R = \frac{38 \times 55 \times 0.7 \times 3 \times 0.7 + 3.7 \times 3 \times 0.2 + 1.5 \times 1.1 \times 0.15}{38.55 + 11.1 + 11.1 + 1.65} = 0.596$$

c) Mid-height of window from floor = 1.46 m

d) Average reflection factor below 1.46 m level

$$R_{fw} = \frac{3.7 \times 3 \times 0.7 + 1.54 \times 9.7 \times 0.7}{11.1 + 14.94} = 0.48$$

e) Average reflection factor above 1.46 m level

$$R_{ew} = \frac{3.7 \times 3 \times 0.7 + 1.54 \times 9.7 \times 0.7}{11.1 + 14.94} = 0.7$$

$$f) \text{ IRC} = \frac{0.85 \times 1.65}{62.4 \times 0.404} (78 \times 0.48 + 10 \times 0.7) = 2.472$$

**B-4 GENERAL NOTE ON DAYLIGHTING OF BUILDING**

**B-4.1** The main aim of day lighting design is how to admit enough light for good visibility without setting up uncomfortable glare. No simple solution may be given as the sky varies so much in its brightness from hour to hour, and from season to season.

**B-4.2** Different visual tasks need differing amounts of lights for the same visual efficiency. The correct amount of light for any task is determined by the following:

- a) Characteristics of the tasks – Size of significant detail, contrast of detail with background and how close it is to the eyes;
- b) Sight of the worker – For example, old people need more light;
- c) Speed and accuracy necessary in the performance of work. If no errors are permissible, much more light is needed; and
- d) Ease and comfort of working – Long and sustained tasks should be done easily whereas workers can make a special effort for tasks of very short duration.

These factors have been made the subject of careful analysis as a result of which tables of necessary levels of illumination have been draw up.

**B-4.3** Levels of lighting determined analytically shall be translated into levels of daylight and then into size of window opening or vice versa for checking the size of window assumed for required levels of daylight.

**B-4.4** One of the many important factors involved in the translation is the lightness of the room surface. The illumination levels in a given room with a finite window will be higher when the walls are light coloured than when these are dark coloured. It is necessary, therefore, at an early stage to consider the colouring of the rooms of the building and not to leave this until later. Lighting is not merely a matter of window openings and quite half the eventual level of lighting may be dependent on the decoration in the room. Whatever may be the colour the occupant wants to use, it is most desirable to maintain proper values of reflectance factors for ceiling, wall and floors so that the level of daylight illumination is maintained.



**Table 19 Percentage Sky Components on the Horizontal Plane Due to a Vertical Rectangular Opening for the Clear Design Sky**  
(Clauses B-1.1 and B-1.6.2)

<b>l/d</b>	0.1	0.2	0.3	0.4	0.5	0.6	0.7	0.8	0.9	1.0	1.1	1.2
<b>h/d</b>	(2)	(3)	(4)	(5)	(6)	(7)	(8)	(9)	(10)	(11)	(12)	(13)
0.1	0.036	0.071	0.104	0.133	0.158	0.179	0.198	0.213	0.225	0.235	0.243	0.250
0.2	0.141	0.277	0.403	0.516	0.614	0.699	0.770	0.829	0.878	0.918	0.950	0.977
0.3	0.300	0.589	0.859	1.102	1.315	1.499	1.653	1.782	1.888	1.976	2.048	2.108
0.4	0.460	0.905	1.322	1.702	2.041	2.337	2.590	2.804	2.984	3.134	3.258	3.361
0.5	0.604	1.189	1.741	2.247	2.700	3.099	3.444	3.740	3.992	4.204	3.383	4.553
0.6	0.732	1.443	2.114	2.732	3.289	3.781	4.211	4.582	4.900	5.171	5.401	5.596
0.7	0.844	1.665	2.441	3.159	3.808	4.385	4.891	5.330	5.708	6.034	6.311	6.548
0.8	0.942	1.858	2.727	3.532	4.262	4.914	5.488	5.989	6.423	6.798	7.119	7.395
0.9	1.026	2.025	2.974	3.855	4.657	5.375	6.011	6.567	7.051	7.470	7.832	8.144
1.0	1.099	2.169	3.188	4.135	5.000	5.776	6.465	7.071	7.600	8.060	8.458	8.803
1.1	1.161	2.294	3.372	4.377	5.296	6.124	6.861	7.510	8.079	8.576	9.008	9.383
1.2	1.215	2.401	3.531	4.586	5.553	6.425	7.204	7.893	8.498	9.027	9.489	9.892
1.3	1.262	2.493	3.668	4.767	5.775	6.687	7.503	8.226	8.863	9.422	9.912	10.339
1.4	1.302	2.573	3.787	4.924	5.968	6.915	7.764	8.517	9.183	9.769	10.283	10.733
1.5	1.337	2.643	3.891	5.060	6.136	7.114	7.991	8.772	9.664	10.073	10.609	11.080
1.6	1.367	2.703	3.981	5.179	6.283	7.287	8.190	8.996	9.710	10.341	10.897	11.386
1.7	1.394	2.756	4.060	5.283	6.412	7.440	8.366	9.192	9.927	10.577	11.151	11.657
1.8	1.417	2.803	4.129	5.375	6.526	7.574	8.520	9.366	10.119	10.786	11.376	11.898
1.9	1.438	2.844	4.190	5.456	6.626	7.693	8.656	9.520	10.289	10.972	11.577	12.112
2.0	1.456	2.880	4.244	5.527	6.714	7.798	8.778	9.656	10.440	11.137	11.755	12.303
3.0	1.559	3.087	4.553	5.937	7.223	8.403	9.478	10.448	11.321	12.103	12.804	13.431
4.0	1.600	3.168	4.676	6.100	7.426	8.646	9.759	10.768	11.678	12.498	13.235	13.897
5.0	1.620	3.208	4.735	6.179	7.525	8.765	9.897	10.925	11.854	12.693	13.448	14.128
10.0	1.648	3.263	4.818	6.289	7.662	8.930	10.089	11.144	12.100	12.965	13.747	14.454
INF	1.657	3.282	4.846	6.327	7.710	8.986	10.155	11.220	12.186	13.060	13.851	14.567

l/d	1.3	1.4	1.5	1.6	1.7	1.8	1.9	2.0	3.0	4.0	5.0	10.0	INF	
h/d	(1)	(14)	(15)	(16)	(17)	(18)	(19)	(20)	(21)	(22)	(23)	(24)	(25)	(26)
0.1	0.256	0.261	0.264	0.268	0.270	0.272	0.274	0.276	0.284	0.286	0.287	0.288	0.288	
0.2	0.999	1.018	1.033	1.046	1.056	1.065	1.072	1.079	1.110	1.118	1.122	1.125	1.125	
0.3	2.157	2.197	2.231	2.259	2.282	2.302	2.318	2.333	2.401	2.421	2.429	2.436	2.437	
0.4	3.446	3.516	3.574	3.623	3.664	3.699	3.728	3.753	3.873	3.909	3.922	3.935	3.937	
0.5	4.659	4.765	4.853	4.928	4.990	5.043	5.088	5.126	5.312	5.366	5.387	5.408	5.410	
0.6	5.761	5.901	6.020	6.121	6.208	6.281	6.344	6.397	6.661	6.739	6.769	6.798	6.802	
0.7	6.751	6.924	7.071	7.198	7.307	7.400	7.481	7.551	7.902	8.006	8.047	8.087	8.092	
0.8	7.632	7.836	8.011	8.162	8.292	8.405	8.502	8.587	9.029	9.164	9.217	9.268	9.276	
0.9	8.413	8.645	8.846	9.019	9.170	9.301	9.415	9.515	10.045	10.214	10.280	10.345	10.355	
1.0	9.102	9.361	9.585	9.780	9.950	10.098	10.228	10.343	10.957	11.162	11.243	11.323	11.335	
1.1	9.709	9.992	10.239	10.454	10.642	10.806	10.951	11.078	11.776	12.017	12.114	12.209	12.224	
1.2	10.243	10.549	10.816	11.050	11.254	11.434	11.593	11.732	12.509	12.786	12.900	13.013	13.030	
1.3	10.713	11.040	11.326	11.577	11.797	11.992	12.163	12.314	13.167	13.478	13.609	13.742	13.762	
1.4	11.127	11.473	11.777	12.044	12.279	12.487	12.670	12.833	13.758	14.102	14.251	14.404	14.427	
1.5	11.493	11.857	12.176	12.458	12.707	12.927	13.122	13.295	14.289	14.666	14.832	15.006	15.033	
1.6	11.817	12.196	12.531	12.826	13.088	13.319	13.525	13.708	14.768	15.176	15.359	15.555	15.585	
1.7	12.104	12.498	12.846	13.154	13.427	13.669	13.885	14.078	15.199	15.638	15.838	16.056	16.091	
1.8	12.359	12.766	13.127	13.446	13.730	13.983	14.208	14.409	15.590	16.058	16.274	16.516	16.554	
1.9	12.587	13.006	13.378	13.708	14.002	14.264	14.498	14.707	15.944	16.441	16.673	16.937	16.980	
2.0	12.789	13.220	13.603	13.943	14.246	14.516	14.758	14.975	16.265	16.790	17.037	17.325	17.372	
3.0	13.993	14.496	14.947	15.353	15.718	16.048	16.346	16.676	18.301	19.051	19.432	19.943	20.046	
4.0	14.493	15.030	15.514	15.951	16.347	16.706	17.033	17.330	19.241	20.142	20.623	21.322	21.495	
5.0	14.742	15.296	15.798	16.252	16.664	17.040	17.382	17.695	19.740	20.740	21.293	22.148	22.393	
10.0	15.094	15.674	16.201	16.681	17.118	17.518	17.885	18.222	20.491	21.681	22.390	23.676	24.238	
INF	15.217	15.806	16.342	16.831	17.278	17.688	18.064	18.410	20.770	22.046	22.838	24.463	26.111	

**Table 20 Percentage Sky Components on the Vertical Plane Perpendicular to a Vertical Rectangular Opening for the Clear Design Sky**  
(Clause B-1.1)

l/d	0.1	0.2	0.3	0.4	0.5	0.6	0.7	0.8	0.9	1.0	1.1	1.2	
h/d	(1)	(2)	(3)	(4)	(5)	(6)	(7)	(8)	(9)	(10)	(11)	(12)	(13)
0.1	0.036	0.141	0.303	0.506	0.734	0.971	1.207	1.432	1.643	2.836	1.011	2.168	
0.2	0.071	0.277	0.594	0.993	1.442	1.910	2.374	2.820	3.236	3.618	3.964	4.276	
0.3	0.103	0.401	0.863	1.445	2.100	2.793	3.475	4.180	4.743	5.306	5.818	6.278	
0.4	0.126	0.491	1.059	1.779	2.597	3.460	4.326	5.166	5.958	6.691	7.359	7.967	
0.5	0.142	0.554	1.197	2.015	2.947	3.937	4.938	5.914	6.842	7.707	8.503	9.228	
0.6	0.154	0.600	1.298	2.187	3.204	4.288	5.389	6.468	7.498	8.464	9.358	10.177	
0.7	0.162	0.634	1.372	2.316	3.397	4.552	5.729	6.887	7.997	9.042	10.013	10.907	
0.8	0.169	0.660	1.429	2.413	3.543	4.754	5.990	7.209	8.382	9.490	10.523	11.476	
0.9	0.174	0.680	1.472	2.487	3.655	4.909	6.192	7.460	8.683	9.841	10.924	11.926	
1.0	0.178	0.695	1.505	2.545	3.743	5.030	6.350	7.657	8.921	10.120	11.243	12.284	
1.1	0.181	0.707	1.532	2.591	3.812	5.126	6.475	7.814	9.110	10.342	11.498	12.573	
1.2	0.183	0.716	1.552	2.626	3.866	5.202	6.575	7.939	9.261	10.521	11.705	12.807	
1.3	0.185	0.723	1.568	2.655	3.910	5.263	6.655	8.040	9.384	10.666	11.873	12.998	
1.4	0.186	0.729	1.582	2.678	3.945	5.312	6.720	8.122	9.484	10.785	12.011	13.155	
1.5	0.188	0.734	1.592	2.697	3.973	5.352	6.773	8.189	9.566	10.883	12.124	13.285	
1.6	0.189	0.738	1.601	2.712	3.996	5.385	6.816	8.244	9.634	10.963	12.219	13.394	
1.7	0.189	0.741	1.608	2.724	4.016	5.412	6.852	8.290	9.690	11.031	12.298	13.484	
1.8	0.190	0.744	1.614	2.735	4.032	5.434	6.882	8.328	9.737	11.087	12.364	13.561	
1.9	0.191	0.746	1.619	2.743	4.045	5.453	6.908	8.360	9.777	11.135	12.420	13.625	
2.0	0.191	0.748	1.623	2.751	4.056	5.469	6.929	8.387	9.811	11.175	12.468	13.680	
3.0	0.193	0.756	1.642	2.785	4.109	5.544	7.030	8.517	9.972	11.371	12.699	13.950	
4.0	0.194	0.759	1.648	2.794	4.124	5.566	7.058	8.540	10.018	11.427	12.767	14.029	
5.0	0.194	0.760	1.650	2.798	4.129	5.574	7.069	8.568	10.036	11.449	12.793	14.060	
10.0	0.194	0.761	1.652	2.801	4.135	5.581	7.080	8.582	10.053	11.470	12.818	14.095	
INF	0.194	0.761	1.652	2.802	4.136	5.582	7.081	8.584	10.056	11.473	12.822	14.095	



l/d	1.3	1.4	1.5	1.6	1.7	1.8	1.9	2.0	3.0	4.0	5.0	10.0	INF
h/d													
(1)	(14)	(15)	(16)	(17)	(18)	(19)	(20)	(21)	(22)	(23)	(24)	(25)	(26)
0.1	2.308	2.433	2.544	2.642	2.730	2.808	2.878	2.940	3.309	3.461	3.536	3.641	3.678
0.2	4.554	4.802	5.022	5.219	5.393	5.549	5.688	5.812	6.547	6.850	7.000	7.211	7.284
0.3	6.690	7.058	7.385	7.677	7.936	8.168	8.375	8.560	9.657	10.110	10.335	10.651	10.760
0.4	8.507	8.900	9.420	9.804	10.146	10.451	10.724	10.968	12.421	13.024	13.323	13.743	13.889
0.5	9.883	10.472	10.999	11.476	11.897	12.273	12.610	12.912	14.712	15.462	15.835	16.360	16.542
0.6	10.922	11.596	12.204	12.752	13.244	13.686	14.084	14.441	16.583	17.478	17.924	18.552	18.771
0.7	11.723	12.465	13.138	13.746	14.296	14.793	15.241	15.646	18.111	19.148	19.665	20.397	20.653
0.8	12.350	13.147	13.873	14.531	15.129	15.670	16.161	16.606	19.361	20.538	21.127	21.961	22.253
0.9	12.847	13.690	14.459	15.159	15.796	16.375	16.902	17.381	20.387	21.701	22.360	23.397	23.625
1.0	13.245	14.126	14.931	15.666	16.337	16.948	17.504	18.012	21.237	22.680	23.408	24.446	24.810
1.1	13.356	14.478	15.314	16.079	16.778	17.416	17.999	18.531	21.946	23.508	24.303	25.441	25.841
1.2	13.827	14.766	15.628	16.418	17.141	17.802	18.407	18.961	22.543	24.208	25.072	26.309	26.745
1.3	14.041	15.003	15.887	16.698	17.442	18.123	18.747	19.320	23.049	24.809	25.735	27.070	27.542
1.4	14.217	15.198	16.101	16.931	17.692	18.391	19.032	19.621	23.480	25.326	26.308	27.441	28.249
1.5	14.364	15.361	16.280	17.125	17.902	18.616	19.272	19.875	23.850	25.772	26.808	28.336	28.880
1.6	14.486	15.497	16.430	17.289	18.079	18.806	19.475	20.090	24.169	26.161	27.245	28.866	29.445
1.7	14.589	15.511	16.556	17.427	18.229	18.968	19.648	20.274	24.444	26.501	27.629	29.340	29.955
1.8	14.675	15.708	16.663	17.545	18.357	19.105	19.795	20.431	24.684	26.799	27.969	29.765	30.416
1.9	14.749	15.791	16.755	17.645	18.466	19.224	19.922	20.567	24.893	27.062	28.270	30.149	30.835
2.0	14.811	15.861	16.833	17.731	18.560	19.325	20.031	20.684	25.077	27.294	28.537	30.496	31.217
3.0	15.120	16.211	17.224	18.164	19.036	19.844	20.594	21.289	26.082	28.619	30.108	32.676	32.742
4.0	15.212	16.316	17.343	18.298	19.185	20.008	20.772	21.483	26.439	29.128	30.745	33.687	35.064
5.0	15.248	16.357	17.390	18.351	19.243	20.073	20.844	21.562	26.592	29.359	31.049	34.232	35.872
10.0	15.283	16.398	17.436	18.403	19.302	20.138	20.917	21.641	26.758	29.624	31.419	35.049	37.513
INF	15.288	16.404	17.443	18.411	19.311	20.148	20.928	21.654	26.785	29.672	31.490	35.274	39.172

**Table 21 Percentage Sky Components on the Vertical Plane Parallel to a Vertical Rectangular Opening for the Clear Design Sky**  
(Clause B-1.1)

l/d	0.1	0.2	0.3	0.4	0.5	0.6	0.7	0.8	0.9	1.0	1.1	1.2	1.3	
h/d	(1)	(2)	(3)	(4)	(5)	(6)	(7)	(8)	(9)	(10)	(11)	(12)	(13)	(14)
0.1	0.728	1.429	2.078	2.600	3.167	3.660	3.964	4.265	4.513	4.717	4.883	5.020	5.132	
0.2	1.429	2.803	4.007	5.221	6.220	7.073	7.790	8.385	8.876	9.278	9.609	9.880	10.103	
0.3	2.068	4.061	5.913	7.580	9.040	10.285	11.337	12.212	12.934	13.528	14.016	14.417	14.747	
0.4	2.529	4.970	7.249	9.312	11.133	12.707	14.042	15.164	16.097	16.870	17.507	18.025	18.458	
0.5	2.852	5.608	8.186	10.529	12.606	14.401	15.952	17.256	18.350	19.262	20.021	20.652	21.177	
0.6	3.086	6.070	8.867	11.415	13.681	15.656	17.353	18.793	20.008	21.027	21.879	22.592	23.189	
0.7	3.259	6.413	9.373	12.074	14.482	16.588	18.402	19.949	21.257	22.359	23.285	24.063	24.716	
0.8	3.389	6.672	9.755	12.573	15.090	17.296	19.201	20.830	22.212	23.380	24.365	25.195	25.895	
0.9	3.489	6.869	10.046	12.955	15.556	17.840	19.817	21.511	22.952	24.173	25.206	26.078	26.816	
1.0	3.565	7.024	10.272	13.250	15.917	18.263	20.297	22.043	23.531	24.795	25.866	26.773	27.542	
1.1	3.625	7.139	10.447	13.481	16.200	18.594	20.674	22.462	23.989	25.288	26.391	27.326	28.121	
1.2	3.672	7.233	10.586	13.663	16.423	18.857	20.973	22.795	24.353	25.681	26.810	27.770	28.587	
1.3	3.709	7.307	10.696	13.807	16.602	19.067	21.213	23.062	24.646	25.998	27.148	28.128	28.963	
1.4	3.739	7.366	10.784	13.924	16.745	19.236	21.406	23.278	24.884	26.255	27.424	28.420	29.271	
1.5	3.763	7.414	10.856	14.018	16.861	19.373	21.563	23.454	25.077	26.465	27.649	28.660	29.523	
1.6	3.783	7.453	10.914	14.095	16.956	19.485	21.692	23.599	25.236	26.638	27.835	28.857	29.732	
1.7	3.799	7.485	10.962	14.158	17.034	19.578	21.798	23.718	25.368	26.781	27.989	29.022	29.906	
1.8	3.812	7.512	11.002	14.211	17.099	19.655	21.886	23.817	25.478	26.900	28.118	29.160	30.052	
1.9	3.824	7.534	11.035	14.254	17.153	19.719	21.960	23.900	25.570	27.001	28.226	29.276	30.175	
2.0	3.833	7.553	11.062	14.291	17.199	19.773	22.022	23.970	25.647	27.086	28.318	29.374	31.279	
3.0	3.876	7.639	11.192	14.463	17.412	20.027	22.316	24.302	26.016	27.491	28.757	29.846	30.783	
4.0	3.888	7.663	11.228	14.511	17.471	20.098	22.398	24.398	26.121	27.606	28.884	29.983	30.930	
5.0	3.893	7.672	11.241	14.529	17.494	20.125	22.430	24.432	26.161	27.650	28.932	30.035	30.986	
10.0	3.897	7.681	11.254	14.546	17.515	20.150	22.459	24.466	26.199	27.693	28.978	30.085	31.041	
INF	3.898	7.682	11.256	14.548	17.518	20.154	22.464	24.471	26.205	27.699	28.985	30.093	31.049	

l/d	1.4	1.5	1.6	1.7	1.8	1.9	2.0	3.0	4.0	5.0	10.0	INF
h/d	(15)	(16)	(17)	(18)	(19)	(20)	(21)	(22)	(23)	(24)	(25)	(26)
0.1	5.225	5.301	5.365	5.418	5.463	5.501	5.533	5.687	5.733	5.749	5.765	5.766
0.2	10.286	10.439	10.565	10.671	10.760	10.835	10.899	11.207	11.296	11.330	11.362	11.365
0.3	15.020	15.246	15.434	15.591	15.724	15.836	15.931	16.390	16.523	16.574	16.623	16.627
0.4	18.816	19.113	19.360	19.568	19.742	19.890	20.015	20.624	20.801	20.868	20.933	20.939
0.5	21.613	21.978	22.275	22.530	22.746	22.923	23.082	23.836	24.056	24.140	24.222	24.229
0.6	23.689	24.109	24.462	24.761	25.014	25.229	25.412	26.229	26.561	26.662	26.759	26.768
0.7	25.267	25.731	26.124	26.458	26.742	26.984	27.192	28.214	28.517	28.634	28.748	28.758
0.8	26.486	26.987	27.412	27.775	28.084	28.350	28.578	29.720	30.065	30.198	30.327	30.339
0.9	27.441	27.972	28.424	28.810	29.141	29.426	29.672	30.927	31.303	31.451	31.596	31.610
1.0	28.196	28.572	29.226	29.633	29.982	30.283	30.544	31.889	32.302	32.467	32.627	32.643
1.1	28.798	29.375	29.869	30.293	30.658	30.973	31.246	32.670	33.117	33.297	33.473	33.491
1.2	29.283	29.878	30.388	30.826	31.204	31.532	31.816	33.309	33.796	33.981	34.173	34.193
1.3	29.676	30.286	30.810	31.261	31.651	31.989	32.283	33.836	34.350	34.550	34.756	34.779
1.4	29.998	30.621	31.157	31.618	32.018	32.365	32.667	34.374	34.813	35.035	35.247	35.271
1.5	30.262	30.897	31.443	31.914	32.322	32.677	32.986	34.641	35.202	35.436	35.663	35.689
1.6	30.482	31.226	31.680	32.160	32.575	32.937	33.253	34.950	35.532	35.776	36.017	36.046
1.7	30.665	31.317	31.879	32.366	32.888	33.156	33.477	35.211	35.812	36.067	36.321	36.352
1.8	30.818	31.477	32.046	32.539	32.967	33.340	33.666	35.435	36.052	36.316	36.584	36.617
1.9	30.948	31.613	32.188	32.686	33.119	33.497	33.828	35.626	35.259	36.532	36.812	36.847
2.0	31.058	31.728	32.308	32.811	33.249	33.631	33.965	35.791	36.438	36.719	37.011	37.048
3.0	31.592	32.291	32.898	33.427	33.889	34.294	34.551	36.640	37.380	37.715	38.107	38.157
4.0	31.748	32.457	33.074	33.611	34.082	34.496	34.860	36.915	37.699	38.063	38.510	38.579
5.0	31.808	32.521	33.142	33.683	34.157	34.574	34.943	37.028	37.834	38.214	38.696	38.781
10.0	31.867	32.584	33.208	33.753	34.231	34.652	35.024	37.144	37.978	38.382	38.927	39.057
INF	31.876	32.593	33.218	33.764	34.243	34.664	35.037	37.162	38.003	38.411	38.978	39.172

## LIST OF STANDARDS

The following list records those standards which are acceptable as 'good practice' and 'accepted standards' in the fulfillment of the requirements of the Code. The latest version of a standard shall be adopted at the time of enforcement of the Code. The standards listed may be used by the Authority as a guide in conformance with the requirements of the referred clauses in the Code.

<i>IS No.</i>	<i>Title</i>
(1) 7662 (Part 1) : 1974	Recommendations for orientation of buildings : Part 1 Non-industrial buildings
(2) 3646 (Part 1) : 1992	Code of practice for interior illumination : Part 1 General requirements and recommendations for building interiors ( <i>first revision</i> )
(3) 2440 : 1975	Guide for daylighting of buildings ( <i>second revision</i> )
(4) 6060 : 1971	Code of practice for daylighting of factory buildings
7942 : 1976	Code of practice for daylighting of educational buildings
(5) 1944  (Part 1 & 2) : 1970  Part 6 : 1981	Code of practice for lighting of public thoroughfares:  Parts 1 and 2 For main and secondary roads (Group A and B) ( <i>first revision</i> )  Lighting for town and city centres and areas of civic importance (Group E)
2672 : 1966	Code of practice for library lighting
4347 : 1967	Code of practice for hospital lighting
6074 : 1971	Functional requirements of hotels, restaurants and other food service establishments
6665 : 1972	Code of practice for industrial lighting
10894 : 1984	Code of practice for lighting of educational institutions
10947 : 1984	Code of practice for lighting for ports and harbours
(6) 3362 : 1977	Code of practice for natural ventilation of residential buildings ( <i>first revision</i> )
(7) 41 (S&T) : 1987	Handbook on functional requirements of buildings (other than industrial buildings)

(8) 72 : 2010

National Lighting Code

\*\*\*\*\*