



भारतीय मानक ब्यूरो

(उपभोक्ता मामले, खाद्य एवं सार्वजनिक वितरण मंत्रालय, भारत सरकार)

BUREAU OF INDIAN STANDARDS

(Ministry of Consumer Affairs, Food & Public Distribution, Govt. of India)

मानक भवन, 9, बहादुर शाह ज़फर मार्ग, नई दिल्ली - 110002

Manak Bhawan, 9, Bahadur Shah Zafar Marg, New Delhi - 110002

Mob.: 7071963270, Phones: 011-23608594, Extn: 8594

Website: www.bis.org.in, www.bis.gov.in

व्यापक परिचालन मसौदा

हमारा संदर्भ: सीईडी 46 /टी-17

10 फ़रवरी 2025

तकनीकी समिति: भारत की राष्ट्रीय भवन निर्माण विषय समिति, सीईडी 46

प्राप्तकर्ता :

1. सिविल अभियांत्रिकी विभाग परिषद, सीईडीसी के सभी सदस्य
2. राष्ट्रीय भवन निर्माण संहिता विषय समिति, सीईडी 46 के सभी सदस्य
3. रुचि रखने वाले अन्य निकाय।

महोदय/महोदया,

निम्नलिखित मानक का मसौदा संलग्न है:

प्रलेख संख्या	शीर्षक
सीईडी 46 (26921) WC	भारत की राष्ट्रीय भवन निर्माण संहिता भाग 8 भवन निर्माण सेवाएं अनुभाग 4 ध्वनि संबंधी, ध्वनिरोधी तथा शोर नियंत्रण [SP7(भाग 8/अनुभाग 4) का चौथा पुनरीक्षण] (आई सी एस नंबर: 01.120: 91.040.01)

कृपया इस मसौदे का अवलोकन करें और अपनी सम्मतियाँ यह बताते हुए भेजे कि यह मसौदा प्रकाशित हो तो इस पर अमल करने में आपको व्यवसाय अथवा कारोबार में क्या कठिनाइयां आ सकती हैं।

सम्मतियाँ भेजने की अंतिम तिथि: 14 मार्च 2025

सम्मति यदि कोई हो तो कृपया अधोहस्ताक्षरी को ई-मेल द्वारा ced46@bis.gov.in पर या उपरलिखित पते पर, संलग्न फ़ॉर्मेट में भेजें। सम्मतियाँ बीआईएस ई-गवर्नेंस पोर्टल, www.manakonline.in के माध्यम से ऑनलाइन भी भेजी जा सकती हैं।

यदि कोई सम्मति प्राप्त नहीं होती है अथवा सम्मति में केवल भाषा संबंधी त्रुटि हुई तो उपरोक्त प्रलेख को यथावत अंतिम रूप दे दिया जाएगा। यदि सम्मति तकनीकी प्रकृति की हुई तो विषय समिति के अध्यक्ष के परामर्श से अथवा उनकी इच्छा पर आगे की कार्यवाही के लिए विषय समिति को भेजे जाने के बाद प्रलेख को अंतिम रूप दे दिया जाएगा।

यह प्रलेख भारतीय मानक ब्यूरो की वेबसाइट www.bis.gov.in पर भी उपलब्ध है।
धन्यवाद।

भवदीय

ह/-

(द्वैपायन भद्र)

वैज्ञानिक 'ई' एवं प्रमुख (सिविल अभियांत्रिकी विभाग)

संलग्न: उपरलिखित



भारतीय मानक ब्यूरो

(उपभोक्ता मामले, खाद्य एवं सार्वजनिक वितरण मंत्रालय, भारत सरकार)
BUREAU OF INDIAN STANDARDS
(Ministry of Consumer Affairs, Food & Public Distribution, Govt. of India)

मानक भवन, 9, बहादुर शाह ज़फ़र मार्ग, नई दिल्ली - 110002
Manak Bhawan, 9, Bahadur Shah Zafar Marg, New Delhi - 110002
Mob.: 7071963270, Phones: 011-23608594, Extn: 8594
Website: www.bis.org.in, www.bis.gov.in

WIDE CIRCULATION DRAFT

Our Reference: CED 46/T-17

10 February 2025

National Building Code of India Sectional Committee, CED 46

ADDRESSED TO:

1. All Members of Civil Engineering Division Council, CEDC
2. All Members of the National Building Code Sectional Committee, CED 46
3. All others interested

Dear Sir/Madam,

Please find enclosed the following draft:

Doc No.	Title
CED 46 (26921) WC	National Building Code of India Part 8 Building Services Section 4 Acoustics, Sound Insulation and Noise Control [Fourth Revision of SP 7 (Part 8/Section 4)] (ICS No. 01.120: 91.040.01)

Kindly examine the attached draft and forward your views stating any difficulties which you are likely to experience in your business or profession, if this is finally adopted as National Standard.

Last Date for comments: 14 March 2025

Comments if any, may please be made in the enclosed format and emailed at ced46@bis.gov.in or sent at the above address. Additionally, comments may be sent online through the BIS e-governance portal, www.manakonline.in.

In case no comments are received or comments received are of editorial nature, kindly permit us to presume your approval for the above document as finalized. However, in case comments, technical in nature are received, then it may be finalized either in consultation with the Chairman, Sectional Committee or referred to the Sectional Committee for further necessary action if so desired by the Chairman, Sectional Committee.

The document is also hosted on BIS website www.bis.gov.in.

Thanking you,

Yours faithfully,

Sd/-
(Dwaipayan Bhadra)
Scientist 'E' / Director & Head
(Civil Engineering Department)

Encl: As above

FORMAT FOR SENDING COMMENTS ON THE DOCUMENT

[Please use A4 size sheet of paper only and type within fields indicated. Comments on each clause/sub-clause/ table/figure, etc, be stated on a fresh row. Information/comments should include reasons for comments, technical references and suggestions for modified wordings of the clause. **Comments through e-mail to ced46@bis.gov.in shall be appreciated.**

Doc. No.: CED 46 (26921) WC

BIS Letter Ref: CED 46/T-17

Title: National Building Code of India Part 8 Building Services Section 4 Acoustics, Sound Insulation and Noise Control [Fourth Revision of SP 7 (Part 8/Section 4)] (ICS No.01.120:91.040.01)

Last date of comments: **14 March 2025**

Name of the Commentator/ Organization: _____

Clause/ Para/ Table/ Figure No. commented	Comments/Modified Wordings	Justification of Proposed Change

NOTE- Kindly insert more rows as necessary for each clause/table, etc

BUREAU OF INDIAN STANDARDS

DRAFT FOR COMMENTS ONLY

(Not to be reproduced without the permission of BIS or used as a Standard)

Draft Indian Standard

**National Building Code of India
Part 8 Building Services
Section 4 Acoustics, Sound Insulation and Noise Control**

[Fourth Revision of SP 7 (Part 8/Section 4)]

(ICS No. 01.120: 91.040.01)

**National Building Code Sectional
Committee, CED 46**

**Last Date for Comments:
14 March 2025**

C O N T E N T S

FOREWORD

- 1 SCOPE
- 2 TERMINOLOGY
- 3 PLANNING AND DESIGN AGAINST OUTDOOR NOISE
- 4 PLANNING AND DESIGN AGAINST INDOOR NOISE
- 5 RESIDENTIAL BUILDINGS
- 6 EDUCATIONAL BUILDINGS
- 7 HOSPITAL BUILDINGS
- 8 OFFICE BUILDINGS
- 9 HOTELS AND HOSTELS
- 10 INDUSTRIAL BUILDINGS
- 11 LABORATORIES AND TEST HOUSES
- 12 MISCELLANEOUS BUILDINGS
- 13 NOISE FROM BUILDING SERVICES

**14 NEIGHBOURHOOD ACOUSTIC SHIELDING DURING
INFRASTRUCTURE DEVELOPMENT**

15 TRAFFIC NOISE BARRIERS

ANNEX A NOISE CALCULATIONS

ANNEX B SPECIFICATION OF SOUND INSULATION

ANNEX C NOISE RATING

ANNEX D OUTDOOR NOISE REGULATIONS IN INDIA

ANNEX E SPECIAL PROBLEMS REQUIRING EXPERT ADVICE

ANNEX F AIRBORNE AND IMPACT SOUND INSULATION

ANNEX G BASIC DESIGN TECHNIQUES FOR NOISE CONTROL IN AIR
CONDITIONING, HEATING AND MECHANICAL VENTILATION
SYSTEM

ANNEX H SUGGESTED EQUIPMENT NOISE DATA SHEET

**ANNEX J INTEGRATION OF NOISE BARRIERS AND NOISE
ABATEMENT MEASURES IN ZONAL AND URBAN PLANNING**

**ANNEX K DESIGN REQUIREMENTS AND PERFORMANCE
EVALUATION OF NOISE BARRIERS**

LIST OF STANDARDS

National Building Code Sectional Committee, CED 46

FOREWORD

This Code (Part 8/Section 4) covers the acoustical, sound insulation and noise control requirements in buildings. Emphasis is laid on planning of buildings *vis-a-vis* its surroundings to reduce noise, and in addition, sound insulation aspects of different occupancies are covered for achieving acceptable noise levels.

This Section was first published in 1970 and was subsequently revised in 1983 and 2005. Some of the important changes in the 1983 version included: specifying of approximate measured noise levels due to various types of traffic (air, rail and road) conditions; elaboration of planning and design features of buildings against outdoor noise; modification of impact sound insulation in residential buildings and hearing damage risk criteria in industrial buildings; recommendations regarding planning of open plan schools against noise; planning and design aspects of hotels and hostels, laboratories and test houses, and other miscellaneous buildings, and planning of office buildings with light weight partitions; and elaboration of the public address system to cover public address system at passenger terminals.

Some of the important changes in the 2005 version included: addition of large numbers of important definitions in line with the existing international practice of usage of terms in the field of acoustics, sound insulation and noise control; inclusion of a new clause on highway noise barrier under provisions on planning and design against outdoor noise; deletion of the clause on public address system; addition of a new clause on cinema; and deletion of existing appendices on 'Constructional Measures for Sound Insulation of Buildings' and 'Sound Insulation values for various types of Materials and Construction'; and addition of eight new informative annexes on noise calculations, specification of sound insulation, noise rating, outdoor noise regulations in India, special problems requiring expert advice, airborne and impact sound insulation, basic design techniques for noise control in HVAC and suggested equipment noise data sheet.

The significant changes that were incorporated in the 2016 revision included the review and update of definitions of various existing terms, along with the introduction of new terms such as noise criteria, sound level difference, ground-borne noise, and structure-borne noise. A new clause on construction noise was introduced, while the provision relating to noise control in open-plan schools was deleted. For auditoria and theatres, a provision for the effective isolation of mechanical equipment, such as lifts, from the building structure was included to prevent noise transmission. Additionally, in auditoria and theatres, a requirement was introduced for adequate damping under lightweight metal roofs, along with an additional lightweight under-deck noise barrier to reduce noise generated by rainfall. The reverberation time of assembly halls in schools, corresponding to 'Maximum for noise control (empty)', was modified, and the reverberation times of classrooms were also revised. The requirement for insulation (R_w) for walls or partitions between rooms in hospitals was modified, along with the recommended maximum reverberation times for very large offices and canteens. The recommended sound isolation value (D_w) between one room and another room in

office was modified, and a similar modification was made for clerical offices where noise does not constitute a major nuisance. The provisions for assembly for partitions in hotels, including those between guest rooms as well as between rooms, corridors, and floors, were also modified. Examples of common types of wall and floor construction with sound insulation were reviewed and updated as required. Additionally, the provisions were updated to address the requirements of persons with disabilities.

This revision has been brought out to incorporate changes based on the experience gained during usage of the last version of this Section. Following are the significant changes made in this revision:

- a) Provisions have been added for noise control in specific industrial occupancies.
- b) A new clause has been included for neighbourhood acoustic shielding during infrastructure development to reduce noise impact on nearby areas.
- c) A new Annex has been introduced detailing the design requirements and performance evaluation of noise barriers to ensure effective noise mitigation.
- d) Provisions on the integration of noise barriers and noise abatement measures in zonal and urban planning have been included.
- e) Provisions for open plan offices have been updated to address concerns regarding data theft and protection of sensitive information.
- f) The terminology has been reviewed and updated [for example, room criteria (RC) has been added for rating the heating ventilation and air-conditioning system-related noise in buildings].

There are two types of noises, that is, air-borne and structure-borne noise. To reduce the intensity of air-borne noise, sound absorbent materials may be used. An absorbent material is one which reduces the intensity of sound reflected from its surface. It may be applied to walls, floors, ceilings or used as furnishings to reduce the sound level by absorption. However, the materials selected for sound absorption shall be consistent with fire safety requirements of the buildings.

To reduce the transmission of air-borne noise, sound insulating materials may be used. Sound insulating materials block the passage of noise through them by virtue of their mass and physical properties. The extent of noise reduction provided by a single homogeneous panel is proportional to the logarithm of mass per unit area. For high values of sound insulation, normally heavy panels are required. Thin sheets of materials do not have adequate mass for providing any appreciable sound transmission loss by themselves. However, when thin sheet materials are used in a double panel construction with an intervening air cavity, this special construction can give extremely high sound transmission loss values considering the mass of the partition, if designed properly. Porous materials lack the mass required to provide any appreciable sound transmission loss, and readily allow sound at most frequencies to be transmitted through them.

To reduce the transmission of structure-borne noise (such as noise generated by impacts) special construction methods and elastic discontinuity in the structure may be used. Structure-borne noise reduction is effected by corner joints, changes in cross-section, changes in materials, etc, in construction. The reduction by these

construction methods is, however, not appreciable especially when a large amount of noise reduction is required over a short distance. In such cases, introduction of an elastic discontinuity in the structure can result in a very large amount of noise reduction. The noise transmission is affected only above a certain lower frequency which depends on the material thickness and the elastic properties of the material. Bonded fibrous materials, rubber elastomers, cork, etc are suitable for curtailing structure-borne noise transmission.

This Section is largely based on the following standards:

IS 1950 : 1962	Code of practice for sound insulation of non-industrial buildings
IS 3483 : 1965	Code of practice for noise reduction in industrial buildings
IS 4954 : 1968	Recommendations for noise abatement in town planning
IS 11050 (Part 1) : 2023	Rating of sound insulation in buildings and of building elements Part 1 Airborne sound insulation (<i>first revision</i>)
IS 11050 (Part 2) : 2023	Rating of sound insulation in buildings and of building elements Part 2 Impact sound insulation (<i>first revision</i>)

Assistance has also been drawn from the following publication, in the formulation of this Section:

BS 8233 : 2014	Code of practice for sound insulation and noise reduction for buildings
----------------	---

All standards, whether given herein above or cross-referred to in the main text of this Section, are subject to revision. The parties to agreement based on this Section are encouraged to investigate the possibility of applying the most recent editions of the standards.

For the purpose of deciding whether a particular requirement of this Section is complied with, the final value, observed or calculated, expressing the result of a test or analysis, shall be rounded off in accordance with IS 2 : 2022 `Rules for rounding off numerical values (*second revision*)'. The number of significant places retained in the rounded off value should be the same as that of the specified value in this Section.

Code users are requested to share their inputs/comments on the draft particularly w.r.t the changes listed above in the foreword; and especially on those text highlighted in yellow in this draft.

Important Explanatory Note for Users of the Code

In any Part/Section of this Code, where reference is made to **'good practice'** in relation to **design, constructional procedures or other related information**, and where reference is made to **"accepted standard"** in relation to **material specification, testing, or other related information**, the Indian Standards listed at the end of the Part/Section shall be used as a guide to the interpretation.

At the time of publication, the editions indicated in the standards were valid. All standards are subject to revision and parties to agreements based on any Part/ Section are encouraged to investigate the possibility of applying the most recent editions of the standards.

In the list of standards given at the end of a Part/Section, the number appearing within parentheses in the first column indicates the number of the reference of the standard in the Part/Section. For example:

a) Good practices [8-4(1)] refers to the Indian Standard(s) give at serial number (1) of the list of standards given at the end of this Part/Section, that is, IS 11050 (Part 1) : 2023 'Rating of sound insulation in buildings and of building elements : Part 1 Airborne sound insulation (first revision)'

DRAFT FOR COMMENTS ONLY*(Not to be reproduced without the permission of BIS or used as a Standard)**Draft Indian Standard***National Building Code of India
Part 8 Building Services
Section 4 Acoustics, Sound Insulation and Noise Control**

[Fourth Revision of SP 7 (Part 8/Section 4)]

(ICS No. 01.120: 91.040.01)

**National Building Code Sectional
Committee, CED 46****Last Date for Comments:
14 March 2025****1 SCOPE**

This Code (Part 8/Section 4) covers requirements and guidelines regarding planning against noise, acceptable noise levels and the requirements for sound insulation in buildings with different occupancies.

2 TERMINOLOGY

For the purpose of this Section, the definitions given below shall apply.

2.1 Ambient Noise – The sound pressure levels associated with a given environment. Ambient noise is usually a composite of sounds from near and far sources, none of which are particularly dominant.

2.2 Audible Frequency Range – The range of sound frequencies normally heard by the human ear. The audible range spans from 20 Hz to 20 000 Hz.

2.3 A-Weighted Sound Pressure, p_A – Value of overall sound pressure, measured in pascal (Pa), after the electrical signal derived from a microphone has been passed through an A-weighting network.

NOTE – The A-weighting network modifies the electrical response of a sound level meter with frequency in approximately the same way as the sensitivity of the human hearing system.

2.4 A-Weighted Sound Pressure Level, L_{pA} – The quantity of A-weighted sound pressure, in decibels (dB), is given by the following formula:

$$L_{pA} = 10 \log_{10} (p_A / p_0)^2$$

where

p_A = A-weighted sound pressure, in pascal (Pa); and
 p_0 = reference sound pressure (20 μ Pa).

NOTE – Measurements of A-weighted sound pressure level can be made with a meter and correlate roughly with subjective assessments of loudness, and are usually made to assist in judging the effects of noise on people. The size of A-weighting in 1/3 octave bands, is shown in Annex A (see **A-5**). An increase or decrease in level of 10 dBA corresponds roughly to a doubling or halving of loudness.

2.5 Background Noise – The sound pressure levels in a given environment from all sources excluding a specific sound source being investigated or measured.

2.6 Break-in – Unwanted sound transmission into a duct or a quiet environment, from outside.

2.7 Break-out – Unwanted sound transmission from the inside of a duct or a noisy enclosure, to the outside.

2.8 Broad Band Noise – Spectrum consisting of a large number of frequency components, none of which is individually dominant.

2.9 Cross-talk – Unwanted sound transmission between one room and another room or space, *via* a duct.

2.10 C_{tr} – Correction term applied against the sound insulation single-number values (R_w , D_w , and $D_{nT,w}$) to provide A-weighting against low frequency performance.

NOTE – The reference values used within the C_{tr} calculation are based on urban traffic noise.

2.11 Decibel – Ten times the logarithm (to the base 10) of the ratio of two mean square values of sound pressure, sound power or sound intensity. The abbreviation for decibel is dB.

2.12 Effective Perceived Noise Level, in Decibel (EPN dB) – The number for rating the noise of an individual aircraft flying overhead is the effective perceived noise level in decibels (EPN dB). The effective perceived noise decibel value takes into account the subjectively annoying effects of the noise including pure tones and duration. In principle, it is a kind of time-integrated loudness level.

2.13 Equivalent Continuous A-Weighted Sound Pressure Level, $L_{Aeq,T}$ – Value of the A-weighted sound pressure level in decibels (dB) of a continuous, steady sound, that within a specified time interval, T , has the same mean squared sound pressure as the sound under consideration that varies with time, and is given by the formula:

$$L_{Aeq,T} = 10 \log_{10} \left(\frac{1}{T} \int_0^T \frac{p_A^2(t)}{p_0^2} dt \right)$$

where

$p_A(t)$ = instantaneous A-weighted sound pressure, in pascals (Pa); and
 p_0 = reference sound pressure (20 μ Pa).

NOTE – Equivalent continuous A-weighted sound pressure level is mainly used for the assessment of environmental noise and occupational noise exposure.

2.14 Equivalent Sound Absorption Area of a Room, A – Hypothetical area of a totally absorbing surface without diffraction effects, expressed in square metres (m^2) which, if it were the only absorbing element in the room, would give the same reverberation time as the room under consideration.

2.15 Façade Level – Sound pressure level measured 1 m to 2 m in front of the façade.

NOTE – Façade level measurements of L_{pA} are usually 2 dB to 3 dB higher than corresponding free-field measurements.

2.16 Free-field Level – Sound pressure level measured outside, far away from reflecting surfaces.

NOTE – Measurements made 1.2 m to 1.5 m above the ground and at least 3.5 m away from other reflecting surfaces are usually regarded as being free-field measurements. To minimise the effect of reflections the measuring position should be at least 3.5 m to the side of the reflecting surface (that is, not 3.5 m from the reflecting surface in the direction of the source). Estimates of noise from aircraft overhead usually include a correction of 2 dB to allow for reflections from the ground.

2.17 Frequency – The number of cyclical variations per unit time. Frequency is generally expressed in cycles per second (cps) and is also denoted as Hertz (Hz).

2.18 Impact Sound Pressure Level, L_i – Average sound pressure level in a specific frequency band in a room below a floor, when it is excited by a standard tapping machine.

2.19 Indoor Ambient Noise – Pervasive noise in a given situation at a given time, usually composed of noise from many sources, inside and outside the building, but excluding noise from activities of the occupants.

2.20 Insertion Loss (L_{IL}) – Insertion loss is generally defined as the difference, in decibels, between two sound pressure levels (or power levels or intensity levels) which are measured at the same point in space before and after a muffler or any other noise control device is inserted between the measurement point and the noise source.

2.21 Noise – Unwanted sound which may be hazardous to health, interferes with communications or is disturbing.

2.22 Noise Exposure Forecast (NEF) – The noise exposure forecast at any location is the summation of the noise levels in EPN dB from all aircraft types, on all runways, suitably weighted for the number of operations during day time and night time.

2.23 Noise Criteria – Numerical indices used to define design goals for the maximum allowable noise in a given space.

2.24 Noise Rating (NR) – Graphical method for rating a noise by comparing the noise spectrum with a family of noise rating curves.

NOTE – Noise rating is described in Annex C.

2.25 Noise Reduction Coefficient (NRC) – A single figure descriptor of the sound absorption property of a material. It is the arithmetic mean of the sound absorption coefficients at 250, 500, 1 000 and 2 000 Hz rounded off to the nearest multiple of 0.05.

2.26 Normalized Impact Sound Pressure Level, L_n – Impact sound pressure level normalized for a standard absorption area in the receiving room.

NOTE – Normalized impact sound pressure level is usually used to characterize the insulation of a floor in a laboratory against impact sound in a stated frequency band (see Annex B).

2.27 Octave Band – Band of frequencies in which the upper limit of the band is twice the frequency of the lower limit.

2.28 Percentile Level, $L_{AN,T}$ – A-weighted sound pressure level obtained using time-weighting ' F ', which is exceeded for N percent of a specified time interval.

Example:

$L_{A90,1h}$ is the A-weighted level exceeded for 90 percent of 1 h.

NOTE – Percentile levels, determined over a certain time interval cannot accurately be extrapolated to other time intervals. Time-weighting ' F ' or ' S ' can be selected on most modern measuring instruments and used to determine the speed at which the instrument responds to changes in the amplitude of the signal. Time-weighting ' F ' is faster than ' S ' and so its use can lead to higher values when rapidly changing signals are measured.

2.29 Pink Noise – Sound with an uninterrupted frequency spectrum and a power which is steady within frequency band and proportional to centre frequency. An example is constant power level per octave band.

2.30 Pure Tone – A sound emitted at a single frequency.

2.31 Rating Level, L_{Ar}, T_r – Equivalent continuous A-weighted sound pressure level of the noise, plus any adjustment for the characteristic features of the noise.

NOTE – This definition is used for rating industrial noise, where the noise is the specific noise from the source under investigation.

2.32 Reverberation Time, T – Time that would be required for the sound pressure level to decrease by 60 dB after the sound source has stopped.

NOTE – Reverberation time is usually measured in octave or third octave bands. It is not necessary to measure the decay over the full 60 dB range. The decay measured over the range 5 dB to 35 dB below the initial level is denoted by T_{30} , and over the range 5 dB to 25 dB below the initial level by T_{20} .

2.33 Sound – A vibrational disturbance, exciting hearing mechanisms, transmitted in a predictable manner determined by the medium through which it propagates. To be audible the disturbance shall have to fall within the frequency range of 20 Hz to 20 000 Hz.

2.34 Sound Exposure Level, L_{AE} – Level of a sound, of 1 s duration, that has the same sound energy as the actual noise event considered.

NOTES

- 1 The L_{AE} of a discrete noise event is given by the formula:

$$L_{AE} = 10 \log_{10} \left(\frac{1}{t_0} \int_{t_1}^{t_2} \frac{p_A^2(t)}{p_0^2} dt \right)$$

where

- $p_A(t)$ = instantaneous A-weighted sound pressure in pascals (Pa);
 $t_2 - t_1$ = stated time interval in seconds (s) long enough to encompass all significant sound energy of the event;
 p_0 = reference sound pressure level (20 μ Pa); and
 t_0 = reference time interval (1 s).

- 2 L_{AE} is also known as LAX (single-event noise exposure level).

2.35 Sound Level Difference, D – Difference between the sound pressure level in the source room and the sound pressure level in the receiving room.

NOTE – D is given by the following formula.

$$D = L_1 - L_2$$

where

- L_1 = average sound pressure level in the source room; and
 L_2 = average sound pressure level in the receiving room.

2.36 Sound Power – The acoustic power of a sound source, expressed in Watts.

2.37 Sound Power Level (L_w) – The acoustic power radiated from a given sound source as related to a reference power level (typically 10-12 watt) and expressed in decibel as :

$$L_p = 10 \log_{10} \left\{ \frac{W}{10^{-12}} \right\}$$

or

$$L_w = 10 \log W + 120$$

where

W = acoustic power, in watts.

By definition, 1 W therefore corresponds to 120 dB for L_w .

2.38 Sound Pressure, p – Root-mean-square value of the variation in air pressure measured in pascal (Pa), above and below atmospheric pressure, caused by the sound.

2.39 Sound Pressure Level, L_p – Quantity of sound pressure, in decibel (dB), given by the formula:

$$L_p = 10 \log_{10} (p/p_0)^2$$

where

p = root mean square sound pressure in pascals (Pa); and
 p_0 = reference sound pressure (20 μ Pa).

NOTE – The range of sound pressures for ordinary sounds is very wide. The use of decibels gives a smaller, more convenient range of numbers. For example, sound pressure levels ranging from 40 dB to 94 dB correspond to sound pressures ranging from 0.002 Pa to 1 Pa. A doubling of sound energy corresponds to an increase in level of 3 dB.

2.40 Sound Receiver – One or more observation points at which sound is evaluated or measured. The effect of sound on an individual receiver is usually evaluated by measurements near the ear or close to the body.

2.41 Sound Reduction Index, R – Laboratory measure of the sound insulating properties of a material or building element in a stated frequency band.

NOTE – For further information see Annex B.

2.42 Sound Source – Equipment or phenomena which generate sound. Source room is the room containing sound source.

2.43 Spectrum – A quantity expressed as a function of frequency, such as sound pressure versus frequency curve.

2.44 Standardized Impact Sound Pressure Level, L'_{nT} – Impact sound pressure level normalized to that in a receiving room having a reverberation time of 0.5 s.

NOTE – Standardized impact sound pressure level is used to characterize the insulation of floors in buildings against impact sound in a stated frequency band (see Annex B).

2.45 Speech Interference Level (SIL) – A descriptor for rating steady noise according to its ability to interfere with conversation between two people. SIL is the arithmetic average of the sound pressure levels in the three octave bands with centre frequencies at 500, 1 000 and 2 000 Hz.

2.46 Standardized Level Difference, D_{nT} – Difference in sound level between a pair of rooms, in a stated frequency band, normalized to a reverberation time of 0.5 s.

NOTE – Standardized level difference takes account of all sound transmission paths between the rooms (see Annex B).

2.47 Structure-borne Noise and Ground-borne

NOTE – When elements of a structure vibrate they radiate noise and, if the vibration is high enough, this noise can be audible. Ground-borne and structure-borne noises are rarely an issue outside buildings or structures.

2.47.1 Ground-borne Noise – Audible noise caused by the vibration of elements of a structure, for which the vibration propagation path from the source is partially or wholly through the ground.

NOTE – Common sources of ground-borne noise include railways and heavy construction work on adjacent construction sites.

2.47.2 Structure-borne Noise – Audible noise caused by the vibration of elements of a structure, the source of which is within a building or structure with common elements.

NOTE – Common sources of structure-borne noise include building services plant, manufacturing machinery and construction or demolition of the structure.

2.48 Transient Sound – Sound which is audible for a limited period of time, for example sound from over flight of an airplane.

2.49 Third Octave Band – Band of frequencies in which the upper limit of the band is $2\frac{1}{3}$ times the frequency of the lower limit.

2.50 Threshold of Hearing – The lowest continuous sound pressure level which will create an auditory sensation for the average human ear. Any sound below these levels will be inaudible and any sound above the threshold will vary in loudness dependent on intensity.

2.51 Vibration Isolation – Reduction of force or displacement transmitted by a vibratory source, often attained by use of a resilient mount.

2.52 Wavelength – The length in space of one complete cycle of a sound wave.

$$\lambda = \frac{(\text{Speed of sound})}{(\text{frequency})} = \frac{(C)}{(f)}$$

2.53 Weighted Level Difference, D_w – Single-number quantity that characterizes airborne sound insulation between rooms but which is not adjusted to reference conditions.

NOTE – Weighted level difference is used to characterize the insulation between rooms in a building as they are; values cannot normally be compared with measurements made under other conditions {see good practice [8-4(1)]}.

2.54 Weighted Sound Reduction Index, R_w – Single number quantity which characterizes the airborne sound insulating properties of a material or building element over a range of frequencies.

NOTE – The weighted sound reduction index is used to characterize the insulation of a material or product that has been measured in a laboratory (see Annex B).

2.55 Weighted Standardized Impact Sound Pressure Level, $L'_{nT,w}$ – Single number quantity used to characterize the Impact sound insulation of floors over a range of frequencies.

NOTE – Weighted standardized impact sound pressure level is used to characterize the insulation of floors in buildings (see Annex B).

2.56 Weighted Standardized Level Difference, $D_{nT,w}$ – Single-number quantity, which characterizes the airborne sound insulation between rooms

NOTE – Weighted standardized level difference is used to characterize the insulation between rooms in a building (see Annex B).

2.57 Weighted Normalized Impact Sound Pressure Level, $L'_{n,w}$ – Single number quantity used to characterize the impact sound insulation of floors over a range of frequencies.

NOTE – Weighted normalized impact sound pressure level is usually used to characterize the insulation of floors tested in a laboratory (see Annex B).

2.58 White Noise – A noise whose spectrum (level) density is substantially independent of frequency over a specified range and has equal power for any range of frequencies of constant band width.

3 PLANNING AND DESIGN AGAINST OUTDOOR NOISE

3.1 General

Planning against noise should be an integral part of town and country planning proposals, ranging from regional proposals to detailed zoning, and three-dimensional layouts and road design within built-up areas. Noise nuisance should be fully recognized in zoning regulations.

3.1.1 Noise is either generated by traffic (road, air, and surface and underground railway) or it arises from zones and buildings within built-up areas (industry, commerce, offices and public buildings), and from public gatherings and social activities. For planning, the noise survey should examine all the possible causes of noise and consider the various factors causing actual nuisance.

3.1.2 Noise by night, causing disturbance of sleep, is more of a nuisance than noise by day. For this reason, housing colonies that adjoin areas with heavy traffic movement during the night are liable to cause serious complaints. Also, the factories that work by night are liable to cause serious complaints if housing estates adjoin them. While planning, care should be taken that housing colonies are adequately set back

from busy airports, state and national highways, factories, main railway lines and marshalling yards.

3.1.3 There are two aspects of defence by planning. The first is to plan so as to keep the noise at a distance. Under this aspect comes the separation of housing from traffic noise by interposing buffer zones, and the protection of schools and hospitals by green belts, public gardens, etc. The second is the principle of shading or screening. This consists of deliberately interposing a less vulnerable building to screen a more vulnerable one or by providing a solid barrier, such as a wall, between the source and the location to be protected.

3.2 Traffic Noise Levels

3.2.1 For Air Traffic

For guidance, approximate noise levels due to various types of aircrafts, measured on ground, when the aircrafts fly overhead at a height of 450 m, are given in Table 1.

Table 1 Typical Noise Levels of Some Aircraft Types
(Clause 3.2.1)

Sl No.	Type of Aircraft	Flyover Noise Levels at 450 m with Take-off Thrust EPN dB
(1)	(2)	(3)
i)	Boeing 737	107
ii)	Boeing 747-200	103
iii)	Airbus A300	101

3.2.2 For Rail Traffic

Noise levels of some typical railway traffic are given in Table 2.

Table 2 Typical Noise Levels of Railway Trains
(Clause 3.2.2)

Sl No.	Type of Train	Noise Level at 30 m, Measured on the Side or in the Direction of Train dBA
(1)	(2)	(3)
i)	Steam train, 60 km/h	85
ii)	Diesel train, 60 km/h	83
iii)	Electric train, 60 km/h	77

3.2.3 For Road Traffic

The level of noise generated by road traffic depends upon such factors as the number of vehicles passing per hour, the type of traffic, the preponderance of heavy vehicles, average speed, gradient and smoothness of traffic flow. The smoothness of traffic flow also affects variability of the noise and is governed by such features as roundabouts and traffic lights, and the volume of traffic and pedestrian movement with their effects on stopping, starting, overtaking and honking. The level of traffic noise fluctuates continuously and the way it does, has a considerable effect on the nuisance caused. For assessing traffic noise, noise is measured in dBA. Because of the fluctuating nature of traffic, noise levels due to different volumes of traffic flow with a varying mix of vehicles are given in Table 3.

Table 3 Typical Noise Levels Due to Free-Flowing Road Traffic
(Clause 3.2.3)

SI No.	Type of Traffic	L ₁₀ 30 m from Edge of Road dBA
(1)	(2)	(3)
i)	5 000 vehicles per 18 hour day (10 percent heavy vehicles), 50 kmph	65
ii)	10 000 vehicles per 18 hour day (20 percent heavy vehicles), 60 kmph	70
iii)	10 000 vehicles per 18 hour day (40 percent heavy vehicles), 80 kmph	75
iv)	20 000 vehicles per 18 hour day (40 percent heavy vehicles), 80 kmph	77

NOTE – The values are applicable to free flowing traffic without honking.

3.3 Outdoor Noise Regulations

The outdoor noise regulations in force from time to time shall be complied with (see also Annex D).

3.4 Planning and Design

3.4.1 For Air Traffic

Near airports two sources of aircraft noise should be considered.

- a) *Flyover noise* – Flyover noise is that which occurs under flight paths close to airports and is the most serious and common problem. As the aircraft passes overhead the noise level at any particular location rises to a peak and then decreases.
- b) *Ground noise* – The noise emitted by an aircraft during ground operations is less variable in direction than flyover noise, but is usually of a longer duration.

3.4.1.1 Aircraft noise may disturb sleep, rest and communication, and as such may be considered potentially harmful to health. It is important that no new development is carried out within areas where the expected noise levels will cause mental and physical fatigue or permanent loss of hearing. In case development in such areas is essential, adequate sound insulation shall be provided for the building.

3.4.1.2 As the problems caused by aircraft noise have become more acute, a number of methods have been devised for evaluating noise exposure in the vicinity of airports. They all combine many factors into a single number evaluation. A commonly used criterion is the noise exposure forecast (NEF). The NEF is used primarily to develop noise contours for areas around airports. It has been accepted generally that noise exposure forecast levels greater than NEF 40 are unacceptable to people while levels less than NEF 25 are normally acceptable. Levels between NEF 25 and 40 may lead to subjective complaints.

3.4.1.3 While it is theoretically possible to provide sufficient insulation to achieve an acceptable indoor noise environment in the area of very high outdoor noise, there is a level above which aircraft noise seriously affects living conditions no matter how much sound insulation has been applied to the dwelling unit. For this reason, it is recommended that no residential development be allowed beyond the NEF 35 level.

3.4.1.4 During summer months, the windows are normally kept open for adequate ventilation. In view of this, no matter how much sound insulation is provided for the building structure, the noise level inside the room can never be less than 10 dB below the outdoor noise level. For very critical buildings, such as buildings necessary for maintaining and supplementing the airport services, and for commercial development, such as hotels, it is possible to provide sealed windows and to centrally air-condition the entire building. However, it is not feasible for most of the residential developments in the country. In such cases proper zoning regulations and siting of vulnerable buildings away from aircraft noise are of vital importance.

3.4.2 *Rail Traffic*

This is a very serious source of noise in built-up areas, both by day and by night. Railway cuttings reduce the spread of noise, whereas embankments extend it. The elevated railway on viaducts or embankment is very common in built-up areas. The elevation increases exposure to noise but in addition the construction of the viaduct may affect the propagation of noise. In this respect solid embankments are preferable to built-up arches, which tend to act as sound boxes. Worst of all are the steel bridges, which greatly magnify the noise due to vibration. Uphill gradients are another feature tending to increase noise, especially of heavy goods trains.

3.4.2.1 Wherever possible, no residential or public building zone should abut onto railway lines, especially on the marshalling yards which is particularly objectionable because of the shrill, clanging and intermittent noise they generate, often at night. The appropriate zones alongside railway lines are industrial and commercial buildings other than office buildings. Where these precautions are not practicable and housing has to abut on to railway lines, every attempt may be made to house as few people as possible in the vicinity of the railway lines.

3.4.2.2 Underground transportation system can be a major cause of disturbance for the neighbouring community. Very high noise levels are propagated to long distances by the underground high speed railway, as a result of wheel-rail interaction. Both airborne noise and ground or structure-borne vibrations are potential sources of complaints. Noise control measures, therefore, need to be considered for the following:

- a) In stations, where high noise levels are produced at the arrival and departure of trains;
- b) In tunnels, during high speed train movement;
- c) Where an underground rail transit system passes close to existing structures or high rise buildings, adequate attention should also be paid to the problem of ground vibration transmitted to the building, and proper isolation should be provided for critical areas;
- d) Wherever elevated railway tracks are provided, adequate measures should be taken to avoid the spread of noise in the surrounding built up areas; and
- e) In transit cars, where sound insulation is of vital importance to provide comfortable conditions for the commuters.

3.4.3 Road Traffic

3.4.3.1 Convoys of long-distance heavy trucks at night moving past through built-up areas cause serious noise complaints. On busy roads, the noise of continuous traffic may be a worse nuisance than that of railways. At least the same precautions may, therefore, be taken in the planning of dwellings in relation to arterial and trunk roads as with railways. Care may be taken that local housing roads do not provide short cuts for heavy traffic through residential areas. Hilly roads present the additional noise of gear changing. Trees with heavy foliage planted on both sides of carriageway help slightly to muffle the noise, provided the foliage extends for a considerable distance (30 m or above).

3.4.3.2 Road traffic may give rise to serious nuisance particularly on busy thoroughfares, between continuous high buildings in main streets, at the traffic lights, near bus stops, on steep slopes and in parking spaces and enclosed yards.

3.4.3.3 For zoning and planning of new buildings in urban areas, it is recommended that external L_{A10} be limited to a maximum of 70 dBA when the dwellings are proposed to have sealed windows and 60 dBA when the dwellings are proposed to have open windows. Indeed, it is desirable to confine major new residential development to locations subject to L_{A10} levels substantially lower than those given above.

It is recognized, however, that within the large urban areas, the use of sites where the external L_{A10} is greater than 60-70 dBA cannot always be avoided. In that case it is suggested to utilize such design solutions as barrier blocks in order to reduce external L_{A10} noise levels to at least 60-70 dBA at any point 1.0 m from any inward looking façade. When the orientation of site and the density of development are such that this cannot be fully achieved some form of dwelling insulation will have to be provided. It should be appreciated that where open windows are necessary, the occupants would have to put up with discomfort if the above conditions are not met.

3.4.3.4 Certain other methods can often be utilized to provide economical and effective protection from noise, as follows:

- a) Methods should be adopted to improve the smoothness of flow and reduce number of stopping and starting. This leads to an improvement even, if it leads to increased flows. Flow linking of traffic lights, for example, may reduce noise nuisance.
- b) Use of roads passing through residential areas should be prohibited to heavy commercial vehicles. An alternative would be to limit use by commercial vehicles to certain times of the day.
- c) Use of honking shall be prohibited near sensitive buildings, such as hospitals and the like.
- d) Barriers shall be provided to shield sites from noise.

3.4.4 *Construction Noise*

3.4.4.1 Construction activities relating to building and infrastructure facilities cause noise disturbance to occupants in existing built facilities located around the site.

Construction noise involves both stationary and mobile sources. Common activities and sources of concern in case of construction noise include excavation and site clearing activities, blasting, piling, operation of batching plants, concrete mixers, pumping, running of diesel generators, drilling and chipping, loading/unloading activities, and truck and other vehicular movement.

The source noise intensity and spectrum is primarily characterized by the type of construction activity, equipment used, ground conditions and associated vehicular movement. Apart from the source characteristics, community noise impact is influenced by the time and sequence of construction related activities.

3.4.4.2 Noise control can be done at the source or in the noise propagation path. While it is preferable to adopt noise control at the source, it may not be practically possible to implement it for some of the construction equipment. Given the diversity of noise sources, mitigation strategies in case of construction noise have to be dealt with appropriately depending on the spectral characteristics of sources.

Source noise control strategies include providing acoustic enclosures for sources like diesel generators, choosing less noisy construction machinery and selecting alternative construction practices which involve lesser noise generation.

Noise control in the propagation paths primarily involves provision of noise barriers around the construction sites.

Positioning of major fixed construction equipment/installations such as batching plants and diesel generators have a significant impact on the noise spectrum and its impact. Also, time of operation and duration of noisy construction activities have significant impact on the resultant annoyance.

3.4.4.3 Due consideration for environmental noise regulation should be given while scheduling and sequencing noisy construction activities.

3.5 Zoning

The zoning of the different cities shall be done by the town planning authorities, taking into account besides other aspects, the noise levels from different occupancies. Wherever necessary, experts in the field may be consulted. For detailed information on noise reduction for town planning schemes, reference may be made to good practice [8-4(2)]. Details regarding the integration of noise barriers and noise abatement measures in zonal and urban planning are provided in Annex J.

3.6 Green Belts and Landscaping

Where relief from noise is to be provided by means of green belts these may be of considerable width and be landscaped. (In case of railway tracks, a minimum distance of 50 m to 70 m may be provided between the buildings and the tracks). The extent of relief that may be derived from the above may be estimated only after considering other environmental factors. Only thick belts of planting (greater than 30 m) are of real value. Strong leafy trees may be planted to act as noise baffles. Shrubs or creepers may also be planted for additional protection between tree trunks; artificial mounds and banks should be formed where practicable. As little hard paving and as much grass as possible may be used. The creation of green belt is particularly advisable on the perimeter of aerodromes, along railway lines and arterial roads, through or past built-up areas and adjoining noisy industrial zones.

3.7 Highway Noise Barriers

Barriers are often the most effective means of reducing traffic noise around residential areas. They have the great advantage that they generally protect most or all of the site. In nearly all situations, a well-designed barrier of even a modest height (say 3 m) can at least ensure that all areas of open space are free from excessive noise levels.

There are two types of barriers that can be built to protect sites; one which are built solely for the purpose of reducing noise and the other which form part of the building complex (barrier blocks). Free standing walls and artificial mounds are typical examples of the first type while single and multi-storeyed utility buildings and garages are the most common form of the second.

Of the two types, laying out barrier blocks of a complex in an appropriate fashion is a better option because they are cheaper and also tend to form a more effective barrier overall because of their greater height and width. Barrier walls or mounds are more limited in their effect than barrier blocks for they protect little more than the area of the site close to ground level essentially because of the lack of height, as continuous walls much higher than 3m are often difficult to construct.

3.8 Use of Acoustic Barriers for Residential, Educational and Hospital Buildings along Highways on City Outskirts (Approximately 4 m to 5 m in height)

3.8.1 Noise barriers can be constructed from a wide variety of materials and designs, but the basic purpose of all the noise barriers is to reduce noise levels at noise sensitive receptors.

3.8.2 A reduction in noise levels up to 10 dBA can be obtained at ground level in an area that is close behind a barrier of considerable height with sufficient insulation value and absorption value. Noise barriers are relatively ineffective at more than 250 m distance from the road.

3.8.3 Innovative combinations, including perforated metal sheeting on one side with the inclusion of absorptive material and a corrugated profile, shall be utilized to enhance the insertion loss provided by the barrier.

3.8.4 Noise barriers may be constructed from a variety of materials, including but not limited to earth, concrete, masonry, metal and wood. Conventional concrete or masonry structures shall be considered the best practicable option for highway noise barriers due to their long-term stability and maintenance-free service characteristics. Laminated glass requires frequent cleaning due to accumulation of dirt, while polycarbonate sheets become opalescent over time as it can absorb water. Plastics are prone to damage from fire and vandalism, and some, such as polyethylene, become brittle after prolonged exposure to sunlight.

3.8.5 The application of multiple-edge noise barriers, also known as profiled noise barriers, shall be implemented in specific applications where enhanced acoustical performance is required to effectively screen a single noise source.

3.8.6 The noise barriers, although highly effective in reducing highway noise levels by significant extent, are subject to certain limitations. To ensure effectiveness, noise barriers shall be designed to be of sufficient height and length to block the view of the road. Barriers are less effective for homes on hillsides or buildings that rise above the barrier.

3.8.7 The design of noise barriers (see also Annex K) shall take into account the following factors:

- a) Visual impact,
- b) Maintenance requirements, and
- c) Cost implications.

3.8.8 The noise barriers may also have negative impacts on the surrounding environment, such as blocking views or creating shadows, which shall be taken into account during the design process.

3.8.9 T-shaped noise barriers with a soft top surface provide superior noise attenuation performance. A T-shaped barrier of 3 m height provides the same performance as a 10 m high plain barrier.

3.8.10 Transparent barriers are associated with lower perceived loudness and noise annoyance compared to opaque barriers, contributing to improved user satisfaction.

3.8.11 The utilization of waste materials, such as plastic, rubber, and bottom ash, is recommended for achieving high noise attenuation with improved cost efficiency.

3.9 Special Problems Requiring Expert Advice

The purpose of noise control is to ensure that people are neither harmed nor disturbed by noise. In addition to provisions given in this Section, special advice may be required for more complex situations, such as those listed in Annex E.

4 PLANNING AND DESIGN AGAINST INDOOR NOISE

4.1 Acceptable Indoor Noise Levels in Buildings

The generally acceptable noise levels inside buildings are given in Table 4.

Table 4 Acceptable Indoor Noise levels for Various Buildings
(Clause 4.1)

SI No. (1)	Location (2)	Noise Level dBA (3)
i)	Auditoria and concert halls	20-25
ii)	Radio and TV studios	20-25
iii)	Cinemas	25-30
iv)	Music rooms	25-30
v)	Hospitals	35-40
vi)	Apartments, hotels and homes	35-40
vii)	Conference rooms, small offices and libraries	35-40
viii)	Court rooms and class rooms	40-45
ix)	Large public offices, banks and stores	45-50
x)	Restaurants	50-55

4.2 Vulnerable Buildings

Some buildings or parts of buildings are especially vulnerable to noise, for example, recording and radio studios, hospitals and research laboratories. These should not be sited near loud noise sources. Most vulnerable buildings contain some areas which are themselves noisy and in such buildings, the less vulnerable elements should be planned to act as noise buffers. Most noisy buildings also contain quiet accommodation, which equally may be planned to act as a buffer between the noisy part of the building and adjoining vulnerable buildings.

4.3 The details of site and internal planning and insulation requirements are covered under individual occupancies (see **5** to **12**) as applicable to the respective character and sources of noise in different buildings.

4.3.1 *Equitable Inclusion of Hearing Impaired Persons in Public Places*

People with hearing impairments have particular difficulty in making out sounds and words in noisy environments. Therefore, adequate sound insulation would minimise noise from both outside and inside the building. Also, low reverberation times are more suitable for hearing impaired persons and should thus be planned while designing the size and shape of the room.

Persons using hearing aids may require quiet areas with induction loops in very noisy information counters or where announcements are made. Induction loops may also be provided in all areas where there are verbal inputs provided, such as conference halls, auditoria, class rooms and cinema halls.

4.4 Sound Insulation of Non-industrial Buildings by Constructional Measures

The desired (acceptable) noise levels and the recommended insulation values for the various areas may be achieved by providing sound insulation treatments by constructional measures. The details of the same are given in Annex F. The recommendations given in Annex F are applicable to non-industrial buildings like residences, educational buildings, hospitals and office buildings.

4.5 Special Problems Requiring Expert Advice – See 3.9 and Annex E.

5 RESIDENTIAL BUILDINGS

5.1 Sources of Noise Nuisance

5.1.1 *Outdoor Noise*

The main sources of outdoor noise in residential areas are traffic (aeroplane, railways, roadways), children playing, hawkers, services deliveries, road repairs, blaring loud-speakers, various types of moving machinery in the neighbourhood and building operations, and captive power generation machinery.

5.1.2 *Indoor Noise*

5.1.2.1 As far as indoor noises are concerned, conversation of the occupants, footsteps, banging of doors, shifting of the furniture, operation of the cistern and water closet, playing of radio, television, music system, cooling and ventilation machinery, etc, contribute most of the noise emanating from an adjacent room or an adjacent building. Noise conditions vary from time to time and noise which may not be objectionable during the day may assume annoying proportions in the silence of the night when quiet conditions are essential.

5.1.2.2 In the case of flats the main sources of noise are from other flats and from stairs, lifts and access balconies. Plumbing noise is another cause. In semi-detached buildings, outdoor noises from streets are noticed more than indoor noises from neighbours.

5.2 Recommendations

5.2.1 Site Planning

The most desirable method is to locate the residential buildings in a quiet area away from the noisy sources like the industrial areas, rail tracks, aerodromes, roads carrying heavy traffic, etc.

5.2.1.1 To minimise ground reflection, the dwellings should be surrounded by the maximum amount of planting and grassed areas and the minimum amount of hard surfacing. This applies particularly to high density areas. Where for maintenance reasons a large amount of hard paving is necessary, it should be broken up by areas of planting and grassing. Narrow hard paved courts should be avoided between adjacent tall buildings.

5.2.1.2 Roads within a residential area should be kept to a minimum both in width and length, and should be designed to discourage speeding. Area-wise planning, with zones from which vehicular traffic is altogether excluded will greatly help to reduce noise. Roads with through traffic should be excluded from residential areas, but where sites have to be developed adjacent to existing major roads the same principles should be observed in the siting of blocks as with railway lines as covered under **3.4.2.1**.

5.2.1.3 Play areas for older children should be sited as far away from dwellings as possible. Special care should be taken with old peoples' dwellings. They should not be placed immediately adjacent to service entries, play spaces, or to any entrances where children may tend to congregate.

5.2.2 Internal Planning

The orientation of buildings in a locality should be planned in such a way as to reduce the noise disturbance from neighbourhood areas. The non-critical areas, such as corridors, kitchens, bathrooms, elevators and service spaces may be located on the noisy side and the critical areas, such as bedrooms and living space, on the quiet side.

5.2.2.1 Windows and doors

Windows and doors should be kept away from the noisy side of the building as given below, wherever possible:

- a) When windows of a building, particularly those of bedrooms in apartments or flats, face roads carrying heavy traffic or other noises where the external noise is of the order of 80 to 90 dBA, the building should be located at a distance of about 30 m from the road, but a distance of 45 m or more, where possible, should be aimed at for greater relief from noise;

- b) When the windows are at right angles to the direction of the above type of noise, the distance from the road should be arranged to be about 15 to 25 m; and
- c) In case another building, boundary wall or trees and plantations intervene between the road traffic and the house/flat further noise reduction is achieved and in such cases the above distances may be reduced suitably.

5.2.2.2 Layout plans

It is desirable that rooms adjoining party walls and above/below party floors should be of similar use. By this means, bedrooms are not exposed to noise from adjoining living rooms, and there is less risk of disturbance of sleep.

In semi-detached houses, the staircase, hall and kitchen should adjoin each other on each side of the party wall, thus providing a sound baffle between rooms requiring quiet conditions.

Bedrooms should not be planned alongside access balconies, and preferably not underneath them. Where the approach is by an internal corridor, a sound baffle may usefully be provided by arranging internal passages and bathrooms between the corridor and the living room or bedrooms.

Kitchens and water-closets should not be planned over living rooms and bedrooms, whether within the same dwelling or over other dwellings. Soil pipes should not be carried in ducts which adjoin living rooms or bedrooms unless the side of the duct next to these rooms is a solid wall containing no inspection openings. Refuse chutes should not be planned next to living rooms or bedrooms.

5.2.3 Sound Insulation

5.2.3.1 Reduction of airborne noise

The weighted sound reduction index, R_w , of partitions between individual rooms or apartments of a building unit shall be as given in Table 5. These values may, however, be suitably increased, where required, for critical areas.

Table 5 Sound Insulation between Individual Rooms (Airborne)
(Clause 5.2.3.1)

SI No. (1)	Situation (2)	R_w dB (3)
i)	Between the living room in one house or flat and the living room and bed-rooms in another	50
ii)	Elsewhere between houses or flats	45
iii)	Between one room and another in the same house or flat	35

NOTES

- 1 Where communicating doors are provided, all doors should be so designed as to provide recommended insulation between the rooms.
 - 2 There are cases when a set of houses or flats have to be built for the people who work at night and sleep during the day. It is desirable to consider the design of at least one such room in each of the houses or flats which will provide an insulation of about 45 dB in that room.
 - 3 The insulation values referred to are applicable with doors and windows shut.
-

5.2.3.2 *Suppression of noise at the source itself*

All items of equipment that are potentially noisy should be selected with care. Water-closet cisterns should not be fixed on partitions next to bedrooms or living rooms. Plumbing pipes should be isolated from the structures. Lift motors should be mounted on resilient supports. Access doors from machine rooms to internal staircases should be well fitting and of solid construction. Special noise control measures may be required for electrical and mechanical services such as diesel generators, outdoor air conditioning units, cooling towers, etc.

5.2.3.3 *Reduction of airborne noise transmitted through the structure*

Reduction of airborne noise requires the use of rigid and massive walls, or acoustically designed dry walls, without any openings. Openings are the major cause of penetration of noise through a barrier. While designing it should be borne in mind that all components should provide a sound transmission compatible with that of the rest of the barrier so that an equivalent amount of sound energy is transmitted through each portion of the barrier.

Ventilating ducts or air transfer openings where provided should be designed to minimise transmission of noise. For this purpose, sound attenuating devices having necessary insertion loss may be installed in these openings.

All partitions should be sealed effectively where they butt against rest of the structure. All doors and windows should be properly gasketed where a high degree of sound insulation is desired.

5.2.3.4 *Reduction of structure-borne noise*

This requires the use of discontinuous or non-homogeneous materials in the construction of the structure.

5.2.3.5 *Reduction of impact noise*

The floor of a room immediately above the bed room or living room shall result in an impact sound pressure level ($L'_{nT,w}$) not greater than 60 dB. Typically, a 150 mm thick concrete floor with thick carpet (12 mm) covering would satisfy this requirement.

5.2.3.6 Main staircases in blocks of flats are often highly reverberant. Some of the surfaces at least (for example, the soffits of stairs and landings) should be finished with sound absorbent materials, wherever required.

6 EDUCATIONAL BUILDINGS

6.1 Sources of Noise Nuisance

6.1.1 Outdoor Noise

The outdoor sources of noise produced on school premises, which cause disturbance within the school, include the noise arising from playgrounds, playing fields and open-air swimming pools. Though playgrounds are used mainly during break periods, they are also used for games and physical education at times when teaching is in progress in the adjoining class rooms.

6.1.2 Indoor Noise

Indoor sources of noise are as follows:

- a) Singing, instrumental and reproduced music which may take place in class rooms and in dining and assembly halls particularly in primary schools. In secondary schools, specialized music rooms are generally provided;
- b) Movement of chairs, desks and tables at the end of one period may disturb a class engaged in a lesson in a room below;
- c) Shutting and openings of doors and windows which may occur at any time during teaching periods;
- d) Audio-visual presentations in class rooms;
- e) Wood and metal workshops, machine shops (engineering laboratories), typing rooms, etc that produce continuous or intermittent sound of considerable loudness;
- f) Practical work carried out in general teaching areas;
- g) Gymnasia and swimming pools;
- h) School kitchens and dining spaces where food preparation and the handling of crockery and utensils persist for the greater part of the school day;
- j) Corridors and other circulation spaces; and
- k) Plumbing and mechanical services.

6.2 Recommendations

6.2.1 Site Planning

Where outdoor noise nuisance exists from local industry, busy roads, railway, airfields, sport grounds or other sources beyond the control of the school authority, school buildings should be sited as far away from the sources of noise, as possible.

6.2.1.1 Rooms should be planned in a manner so that the minimum amount of glazing is placed on the side facing the external noise.

6.2.1.2 Noises arising from the activities of a school and from the use of the buildings after school hours may constitute a nuisance to occupants of surrounding property; therefore, it is desirable to place playgrounds, workshops, swimming pools, music rooms, assembly halls and gymnasias as far away as possible from buildings which require a quiet environment.

6.2.2 *Internal Planning*

The following principles should be observed in the detailed planning of educational buildings:

- a) *Grouping* – Noisy rooms should be separated from quiet ones, if possible. In general, it is desirable that rooms should be grouped together in accordance with the classification given in **6.2.4.1**.
- b) *Windows and ventilators* - Windows of noisy and quiet rooms should not open on to the same courtyard or be near to one another. Skylights and ventilators over noisy rooms should be avoided, if they are likely to be a source of nuisance to adjacent upper floors.
- c) *Doors* – Swing doors into rooms should only be used where no problem of sound transmission exists. Reduction of insulation between rooms and corridors due to doors shall be borne in mind. The type and method of fitting of doors is important and necessary care shall be paid in this respect.
- d) Sliding partitions, if used, should be acoustic operable partitions. Pass-through doors, if provided, should be acoustic doors with drop seals.
- e) *Open planning and circulation areas* – Where open planning is used to permit spaces, such as assembly halls, dining rooms or entrance halls to be used in association with each other or for circulation, the degree of disturbance caused by interfering noise to teaching areas needs careful consideration; traffic through such areas should be strictly controlled; full use should be made of sound absorbent treatments to reduce the spread of noise from one space to another (see **6.2.3**).

If rooms have large glazed panels or ventilation openings facing directly on the circulation areas, human traffic passing by the rooms should be controlled. Preferably baffled ventilation system or double windows should be used. Fan-lights over doors should be fixed and glazed.

- f) *Furniture* – In all educational buildings, regardless of the character of the floor finish, rubber buffers should be fitted to the legs of chairs and tables.

6.2.3 *Noise Reduction within Rooms*

Sound absorbent materials play a useful part in reducing the built-up or air-borne noise at source. In rooms, such as class-rooms, assembly halls and music rooms, a fairly short reverberation time under occupied conditions is one of the requirements of the acoustic design. The maximum reverberation times permissible for this purpose are

usually short enough to give adequate noise control but in addition, the reverberation time should not be excessive under empty conditions, because noise may occur in these rooms with very few occupants. Table 6 gives the reverberation times often arranged in occupied rooms for acoustic reasons and the maximum times recommended in the empty rooms for noise reduction; the times given are for a frequency of 500 Hz, but they should not be greatly exceeded at any frequency. When rooms are used for a variety of purposes, the reverberation period appropriate to the major use should be adopted.

6.2.3.1 Special attention should be given to noise reduction in schools for the hearing impaired and schools for the visually impaired. Hearing impaired children are taught by means of hearing aids which cannot be used satisfactorily in high noise levels or in reverberant conditions. Visually impaired children depend on good hearing for understanding speech and for detecting changes in environment. In both these types of schools, noise levels should be kept low and reverberation times short. As an example, the reverberation times in empty class-rooms should not exceed 1.0 s in schools for the visually impaired or 0.5 s in schools for the hearing impaired.

Table 6 Reverberation Times in Schools
(Clause 6.2.3)

SI No.	Room	Reverberation Time s	
		Usual for Acoustic Reasons (Full)	Maximum ¹⁾ for Noise Control (Empty)
(1)	(2)	(3)	(4)
i)	Assembly halls	1.0 - 1.25 according to size	1.5 – 2.0 according to volume of hall
ii)	Music teaching rooms	0.75 - 1.25	1.5
iii)	Gymnasia and indoor swimming pools	–	1.5
iv)	Dining rooms	–	1.25
v)	Classrooms	0.6	1.1
vi)	Headmasters room and staff rooms	0.5 - 1.00	1.0

¹⁾ Shorter reverberation times are desirable for noise control, whenever possible.

6.2.4 Sound Insulation

6.2.4.1 Airborne noise

For purposes of sound insulation, rooms in educational buildings may be classified as follows:

Class A	Noise Producing	a) Workshops b) Kitchens c) Dining Rooms d) Gymnasiums e) Indoor Swimming Pools
Class B	Noise producing but needing quiet at times	a) Assembly halls b) Lecture halls c) Music rooms d) Typing rooms
Class C	Average	a) General class rooms b) Practical rooms c) Laboratories d) Offices
Class D	Rooms needing quiet	a) Libraries b) Studies
Class E	Rooms needing privacy	a) Medical rooms b) Staff rooms

6.2.4.2 The recommended minimum sound reduction (D_w) between rooms of the same class is as follows:

Class A	–	25 dB
Class C or D	–	35 dB
Class B or E	–	45 dB

6.2.4.3 Where a room is likely to have a dual use, for example, a dining room to be used as a class-room, the higher sound insulation value should be used.

6.2.4.4 The recommended minimum sound reduction (D_w) between rooms in different classes is 45 dB subject to the following:

- a) In schools or institutes with a technical bias where noisy activities, such as sheet metal work, plumbing and woodwork, are likely to be practised extensively in normal hours, workshops should be regarded as a special category requiring more than 45 dB isolation (D_w) from rooms of any other class.

- b) Assembly halls and music rooms are special cases in that, as well as producing noise, they also require protection from it and may need more than 45 dB isolation (D_w) from rooms in Class A, if the latter are very noisy.
- c) Circulation spaces may vary from a long and frequented corridor to a small private lobby and it is therefore difficult to give precise recommendations to cover them. For partitions between rooms in Class C and most corridors, an R_w of 35 dB for the partition itself is adequate. For partitions between rooms in other classes and corridors, more or less insulation may be necessary, depending upon the specific usage.
- d) The problem of noise in circulation areas is as a rule greatly mitigated in schools by the fact that classes usually change rooms together at regular times. In colleges and evening institutes, however, this is much less true and in such buildings particular attention should be paid to insulation between rooms and corridors.

6.2.4.5 Impact noise

In the case of schools, the concrete floor of the room immediately above the teaching rooms shall provide an impact sound pressure level, $L'_{nT,w}$ not greater than 70 dB. For example, a covering of 6 mm linoleum or cork tiles on concrete floor (hollow or solid) weighing not less than 220 kg/m² will usually meet the above requirement.

7 HOSPITAL BUILDINGS

7.1 General

Problems of noise control vary from hospital to hospital but the principles outlined below apply to all types. A quiet environment in hospitals is desirable for patients who are acutely ill. Staffs require quiet conditions for consultations and examinations and also in their living and sleeping quarters. There have been rapid rises in noise levels in hospitals due to the higher levels of outdoor noise, increasing use of mechanical and mobile equipment (some of which is now brought much nearer to the patient in order to facilitate nursing procedure) and the introduction of loudspeaker, radio, television and call systems. Noise control in the hospital is made much more difficult by the extensive use of hard washable surfaces which reflect and intensify the noise. In most hospitals, windows to the open air and fanlights to corridors are usually open for the purpose of ventilation, admitting noise from outside and allowing it to spread through the building.

7.2 Sources of Noise Nuisance

7.2.1 Outdoor Noise

This may be classified into two main categories:

- a) Noise from sources outside the hospital premises, for example, traffic and industrial noises; and
- b) Noise from sources outside the building but usually within the control of the hospital authority, for example, ambulances, motor-cars and service

vehicles, fuel and stores deliveries, laundries, refuse collection, trucks and trolleys.

7.2.2 Indoor Noise

A hospital is a complex building with many services and the numerous internal sources of structure-borne and airborne noises are grouped into three main categories:

- a) Noise consequent upon hospital routines. This category includes sources which transmit noise through both structure-borne and air-borne paths, many of which may be quite near to patients particularly those in wards, such as the following:
 - 1) Wheeled trolleys of various kinds, for food and medical supplies;
 - 2) Sterilizing equipment;
 - 3) Sluice room equipment including bedpan washers;
 - 4) Ward kitchen equipment;
 - 5) Footsteps;
 - 6) Doors banging;
 - 7) Handling of metal or glass equipment;
 - 8) Noises caused during maintenance and overhaul of engineering services; and
 - 9) Vacuum cleaners, mechanical polishers, etc.
- b) Loudspeaker, radio or television, audible call system, telephone bells and buzzers, and other air-borne noises, such as loud conversation; and
- c) Noises from fixed or mobile equipment and services not directly concerned with hospital routines. These include all the fixed services as given below:
 - 1) Plumbing and sanitary fittings;
 - 2) Steam hot and cold water and central heating pipes;
 - 3) Ventilation shafts and ducts;
 - 4) Fans
 - 5) Boilers;
 - 6) Pumps;
 - 7) Air compressors;
 - 8) Pneumatic tubes;
 - 9) Electrical and mechanical motors and equipment;
 - 10) Lifts;
 - 11) Laundry equipment; and
 - 12) Main kitchen equipment (refrigerators, mixers, steam boilers, etc).

7.3 Recommendations

7.3.1 Site Planning

Hospital sites with their high degree of sensitivity to outside noise should be as far away from outside sources as may be compatible with other considerations, such as

accessibility and availability of services. The building should be so arranged on the site that sensitive areas like wards, consulting and treatment rooms, operating theatres and staff bedrooms are placed away from outdoor sources of noise, if possible, with their windows overlooking areas of acoustic shadow.

7.3.2 Detailed Planning

There is a very large number of unit and room classification in hospital design and in planning the units in relation to each other and to the common services, (such as X-ray departments, operating theatre suits and main kitchens), noise reduction in the sensitive areas should be weighed carefully against other design factors. Special care in overall planning and internal planning against noise is required in the planning within the building of units which are themselves potential noise sources, for example, children's wards and outpatients' departments, parts of which require protection against noise.

7.3.2.1 Unloading bays, refuse disposal areas, boiler houses, workshops and laundries are examples of service units which should be as far from sensitive areas as possible.

7.3.2.2 The kitchen is a constant source of both air-borne and structure-borne noise and should preferably be in a separate building away from or screened from the sensitive areas. If this is not possible and the main kitchens shall form part of a multi-storey building, noise control is easier if they are placed below and not above the wards and other sensitive rooms so as to facilitate the insulation of the equipment and machinery in order to reduce the transmission of structure-borne noise to a minimum.

7.3.2.3 In ward units, the kitchens, sluice rooms, utility rooms, sterilizing rooms and other ancillary rooms, need to be placed quite near to the beds if they are to fulfil their purposes, which are all sources of noise. Some form of noise baffling between open wards and rooms of this kind will be needed.

7.3.3 Reduction of Noise at Source

In view of the difficulty of suppressing noise in hospital buildings, it is important to eliminate noise at its source, wherever possible.

7.3.3.1 Use of resilient material

Mats of rubber or other resilient material on draining boards and rubber-shod equipment will greatly reduce noise from utility rooms, sluice rooms and ward kitchens. The use of plastics or other resilient materials for sinks, draining boards, utensils and bowls would also reduce the noise. Many items of equipment especially mobile equipment, such as trolleys, beds and movable furniture, may be silenced by means of rubber-tyred wheels and rubber bumper and the provision of resilient floor finishes (see **7.3.4.1**). The latter also reduces footstep noise. Silent type curtain rails, rings and runners should be used. Lift gates and doors should be fitted with buffers and silent closing gear. Fans and other machinery should be mounted on suitable resilient mountings to prevent the spread of noise through the structure.

7.3.3.2 Other measures

Noise from water or heating pipes may be reduced by installing systems which operate at comparatively low pressure and velocities. Silencing pipes and specially designed flushing action reduce water closet noise at source and make structural measures easier to apply. The ventilation system should be designed so as not to create a noise problem. Silent closers should be fitted to doors.

7.3.4 Reduction of Noise by Structural Means

7.3.4.1 Insulation

Since the various departments or units may be planned in many ways, only general guidance on the insulation values for walls and partitions is as given below:

- a) It is recommended that walls or partitions between rooms should normally have an R_w of at least 45 dB. Higher values of R_w of at least 50 dB are necessary where a noisy room is adjacent to one requiring quiet conditions. Doors should be solid with close fitting in the frames.
- b) There is little insulation value in double swing doors and where these are fitted to a noisy room the opening should be planned so that it is screened from areas requiring quiet by a baffle lobby lined with absorbent material. Very high insulation values may be necessary in special cases and exceptional measures may be required.
- c) Solid floors with floating finishes and resilient surfaces are necessary particularly between wards and other parts of the building. Ordinary timber board on joist floors should never be used.
- d) Conduits, ventilation ducts, chases, etc, should be constructed so as not to form easy by-pass for disseminating noise about the building, and should be provided with sufficient sound insulation. Pipe ducts should be completely sealed around the pipes where they pass through walls or floors. Ducts carrying waste or water pipes should be lined with sound insulating material to prevent noise from the pipes passing through duct walls into the rooms through which they pass.

7.3.4.2 Absorption

Most surfaces in hospitals should be easily cleanable, so as to prevent the build-up of bacteria which may cause cross-infection. Many sound absorbent materials of a soft nature and difficult to clean are unsuitable for use in some hospital areas and lose much of their effectiveness, if painted for hygienic reasons.

Some porous materials with very thin non-porous coverings (like mineral wool covered with thin plastic sheets) have good sound absorption and when covered with a perforated sheet metal facing can be used in most areas requiring a washable acoustical treatment. In noisy areas, such as corridors and waiting rooms, however, a wider choice of absorbents is available.

In the ward, bed curtains, window curtain, etc add to the absorbent properties of the room and help reduce reverberation in otherwise hard surfaced surroundings.

7.3.5 Sensitive areas such as operation theatres, doctors' consultation rooms, intensive care units (ICU) require special consideration against noise control. Apart from outdoor noise, a common problem is the transmission of sound between the consulting room and the waiting room. To ensure silence, a sound isolation D_w of 45 dBA, between the rooms shall be provided. If the doors are directly connected by a single communicating door it will not be possible to achieve these values of isolation D_w . To obtain 40-45 dBA insulation between communicating rooms, it is necessary to provide two doors separated by an air gap, such as a lobby or corridor.

8 OFFICE BUILDINGS

8.1 General

Modern office buildings are often noisier than older buildings due to the use of thinner and more rigid forms of construction, harder finishes, more austere furnishings and use of business machines.

8.2 Sources of Noise Nuisance

8.2.1 Indoor Noise

Main sources of indoor noise include the following:

- a) Office machines, such as keyboards, typewriters, and printers;
- b) Telephonic conversation;
- c) Noise from the public admitted to the building;
- d) Footsteps, voices and slamming of doors in circulation spaces, lift doors and gates;
- e) Sound reproduction in staff training rooms, conference rooms and recreation rooms, etc;
- f) Handling of crockery and utensils in canteens and kitchens; and
- g) HVAC and lift machinery.

8.3 Recommendations

8.3.1 Site Planning

Rooms demanding quiet conditions should be placed on the quiet side of the site. Even on quiet thoroughfares, these rooms should also not be planned at street level. They should also not be planned on enclosed yards used for parking of cars, scooters, etc. Where, however, the problems cannot be resolved by planning, the provision of double windows may be necessary.

8.3.2 Detailed Planning

8.3.2.1 Noise reduction within rooms

The reverberation time should not exceed 1.0 s in all general offices of the types listed in **8.3.2.2** to **8.3.2.6**. In small private offices, the reverberation time should not exceed

0.75 s, in very large offices the reverberation time may be increased to 1.0 s. For canteens, the recommended maximum reverberation time is 1.0 s.

NOTE – All reverberation times are specified for a frequency of 500 Hz.

8.3.2.2 Large general offices

The grouping of departments and machines together in one room should be avoided, wherever possible. Where supervision is necessary the provision of glazed screens carried up to the ceiling should be considered. If it is essential to the work of an office for machine operators and clerks to work side by side in the same room, the machines should be enclosed by panels or low screens lined with absorbent material and the ceiling should be sound absorbent. In addition, the machines should be as quiet as possible in operation and mounted on suitable resilient mountings.

NOTE – A quiet area should be planned for prolonged telephonic conversation.

8.3.2.3 Light weight construction

Modern construction methods and economy dictate the use of light weight construction for many office buildings. While the lightweight materials lead to fast fabrication and erection and also effect considerable economy in the building structure, they may lead to tremendous sound insulation problems between adjacent offices and areas. Light weight construction is also frequently employed for the subdivision of large space into executive cabins and secretarial areas. Where such construction is considered desirable, efforts should be made to provide a double-skin panel. The panels should be isolated from each other as far as possible either by the use of separate framing or by the use of elastic discontinuities in the construction, and a sound absorbing material may be introduced in the air cavity between the panel. The partitions should be full height up to the bottom of the roof above and any openings required for air movement should be provided with sound attenuators compatible with the rest of the partition.

When light weight floors are provided in multi-use buildings, adequate attention shall be paid to the question of air-borne and structure-borne noise transmission from the upper floors to the floors below. For effective reduction of air-borne noise, a double panel hollow floor construction may be employed with some heavy sound damping material introduced between the panels and the panel isolated from each other. The sound damping material could be sand, mineral wool, etc. In case impact noise isolation is also required, the upper panel should be effectively isolated from the rest of the floors and building structure. The choice of the isolation layer would of course depend upon the lowest frequency of interest.

Another point to be kept in mind when going in for light weight construction is to ensure that the light weight panels are not in resonance with the natural frequencies of any mechanical equipment installed inside the building. Light weight materials have high natural frequencies well within the audio range and may resonate or vibrate due to an applied vibratory force. This vibratory force is caused by mechanical equipment, road traffic, rail traffic, etc. Special measures also need to be taken to isolate either the source or the building so as to reduce the amount of vibration transmitted to the building structure.

8.3.2.4 Open plan offices

A new concept in office planning is the use of open plan offices. Large open floor spaces are converted into an office area with senior executives, junior executives and secretarial staff all seated within the same area without the use of any partitions or walls. While this method of planning is appreciated, it leads to a problem of inadequate acoustical privacy between adjacent work spaces. Speech privacy in open plan offices is defined by the speech interference level of intruding noise. Speech privacy between two adjacent rooms or spaces is, therefore, a function of two key parameters; noise reduction of the intervening partition and background noise levels.

Special design measures are, therefore, required to reduce the level of intruding sounds at work places to acceptable low value so that people are not disturbed and adequate privacy is maintained. Some special measures which might be considered for such open plan offices are the use of an acoustical ceiling together with partial height barriers between work spaces, all designed to provide adequate privacy between adjacent work spaces. In addition use may have to be made of an electronic background masking noise system which provides a constant level of a generally acceptable background noise in the entire office area. The masking noise system is a very useful concept in open plan office design because by raising the background level at every workplace, intruding noises are made less disturbing. A background music system cannot serve as a noise masking system because the music does not have a constant spectrum or sound level. In fact the background noise masking system shall be introduced gradually without the knowledge of employees. The air-conditioning system can also be used to generate background masking noise if the noise level from the fans, ducts and grills is suitably tailored to generate the desired frequency spectrum. However, it is not simple to predict the noise level of air-conditioning components accurately. On the other hand, the electronic system enables both the level and the spectrum of the background noise to be accurately adjusted to suit individual job requirements.

8.3.2.4.1 In addition to comfort, speech privacy and sound insulation play a critical role in preventing data theft or leakage of sensitive information. Improper acoustical design can lead to unauthorized access to confidential conversations, especially in organizations handling financial data, legal matters or classified projects. Speech leakage across open-plan offices occurs when sound waves are transmitted either directly or indirectly through reflective surfaces, openings, or poorly isolated barriers. The sound control measures given below shall be employed to mitigate this risk and ensure information security.

- a) *Control of direct and indirect sound paths* – Partial-height barriers alone are often insufficient to block sound transmission, as sound can travel over the barriers and reflect off ceilings, windows, or walls. To prevent sound leakage, barriers between workstations shall be designed with sound-absorptive materials to reduce reflections. In high-security zones, barriers should ideally reach ceiling height to limit the direct path of sound waves. Additional sealing measures, such as acoustic baffles or sound-blocking panels near ceilings, can help to further contain sound within specific zones.

- b) *Masking noise for speech concealment* – Even with physical barriers in place, speech masking systems play a crucial role in enhancing speech privacy by rendering conversations unintelligible beyond a specific range. These systems should generate uniform background noise across the entire office, tuned to a frequency spectrum that aligns with typical human speech, thereby reducing the clarity of overheard conversations. Care shall be taken to avoid variations in masking noise across different zones, as uneven noise profiles can inadvertently create ‘quiet spots’ where speech becomes more easily discernible.
- c) *Acoustic zoning for sensitive areas* – Workspaces dealing with confidential or sensitive data shall be zoned acoustically to limit sound propagation beyond their intended boundaries. These zones can be created through sound-dampening partitions, low-noise areas, and placement of workstations away from high-traffic zones. Additionally, team discussions or meetings involving classified topics should occur in acoustically treated rooms with sealed doors and walls to avoid inadvertent sound leakage into adjacent spaces.
- d) *Control of reflective surfaces* – Reflective surfaces such as glass partitions, metal ceilings, and large windows can amplify sound reflections, making speech intelligible at greater distances. Such surfaces shall be treated with sound-absorbing films, acoustic panels, or curtains to minimize reflection. Flooring materials such as carpets or rugs should also be used to reduce the transmission of footfall noise, which could otherwise interfere with the effectiveness of masking systems.
- e) *Air-conditioning systems and noise control* – Although air-conditioning systems can generate a degree of background noise, it is critical to ensure that the noise they produce remains predictable and stable. Inconsistent air-conditioning noise can undermine masking systems, creating intermittent quiet periods that increase the risk of speech leakage. Ducts, grilles, and vents shall be designed and placed carefully to maintain a uniform noise level throughout the office area, ensuring no unintended listening opportunities arise.

8.3.2.5 Office equipment rooms

It is important that machines like keyboards, typewriters, printer, etc, should be quiet in themselves and also be fitted with resilient pads, to prevent the floors or tables on which they stand from acting as large radiating panels. It is desirable to locate machines further apart and to apply sound absorbent treatment to the ceiling.

8.3.2.6 Banking halls

If banking halls are large and lofty, noise nuisance tends to be aggravated. It is advisable to avoid high reflective ceilings. The worst effects may be reduced by segregating the noise from the quiet operations and screening one from the other and by applying sound absorbent materials to the surfaces of the ceilings, screens and nearby walls. Resilient flooring is also recommended.

8.3.2.7 Public offices and waiting spaces

Noise nuisance may be minimised by the provision of resilient flooring, sound absorbent ceilings and heavy full height screens between the public space and the clerical office.

8.3.2.8 Canteens

The provision of a sound absorbent ceiling, resilient flooring and the use of plastics/**wooden** trays and tables with quiet tops are recommended.

8.3.2.9 Circulation spaces

The effective length of long corridors should be limited by providing swing doors at intervals. Hard floor finishes and board and batten floors in corridors should be avoided. The provision of a sound absorbent ceiling in corridors is recommended. Floor ducts should be planned on one side of corridors.

The noise from slamming of doors may be reduced by fitting automatic quiet action type door closers. Door buffers are useful but may reduce insulation of air-borne sound due to the inevitable gaps between buffers. Continuous soft, resilient strip let into the door frames is preferable. The use of quiet action door latches is recommended.

Staircases and lifts should be isolated from quiet rooms and should have silent type doors.

8.3.3 Requirement of Sound Insulation

With open window (single or double) the sound reduction (D_w) will be 5 - 10dB, and with sealed double windows it will be 40 - 45 dB. Intermediate values are obtainable with closed openable windows (single or double) but only, of course, at such times as ventilation may be dispensed with. Having to choose between ventilation and noise exclusion is a serious handicap to efficient working in offices. In large office blocks on noisy sites, consideration should be given to the provision of sealed double windows and mechanical ventilation at least in the offices on the sides of the building exposed to noise.

8.3.3.1 The insulation necessary between adjoining rooms, both horizontally and vertically, depends upon the amount of noise created within the rooms, the amount of intruding noise and whether it is important that conversation should not be overheard between rooms. Generally, a sound isolation value (D_w) of 40 dB between one room and another room in office is recommended.

8.3.3.2 The following list may be considered as broad classification of noise producing rooms and rooms requiring quiet though many offices fall into both categories. Where rooms in opposing categories are planned adjacent to each other, a sound reduction (D_w) of at least 45 dB should be provided between them.

<i>Sl No.</i>	<i>Noise Producing Rooms</i>
i)	Entrance and reception halls, staircases and corridors used by the public
ii)	Lifts and lift halls
iii)	Motor and plant rooms
iv)	Lavatories
v)	Public offices
vi)	Canteen and kitchens
vii)	Office machine rooms and typing pools
viii)	Recreation rooms
ix)	Large general offices
x)	Cinemas and projection rooms

<i>Sl. No.</i>	<i>Rooms Requiring Quiet Conditions</i>	
i)	Executive's rooms, Conference rooms and Board rooms	
ii)	Interview rooms	
iii)	Offices for one or two persons	
iv)	Medical officer's rooms	
v)	Sick rooms	
vi)	Rest rooms	
vii)	Libraries	
viii)	Telephoning rooms	
	a)	<i>D_w</i> 45 dB
	b)	40 dB
	c)	30 dB

8.3.3.3 It is recommended that the minimum sound reduction index, R_w for floors should be 45 dB, and the floors should have a resilient finish.

9 HOTELS AND HOSTELS

9.1 General

Hotels and hostels are primarily used as dwelling units, and hotels also provide for public entertainment. The most serious risk, of course, is disturbance to sleep, and adequate care, therefore, needs to be taken to protect the occupants from being disturbed by outdoor and indoor noise.

9.1.1 Outdoor Noise

Hotels near railway stations, airports, highways and those situated in highly urbanized areas are especially vulnerable to outdoor noise. The outdoor noise in many of the areas is of a high level even late at night and in the early morning. The noise could also be due to other types of activities such as building construction activity (pile driving, concrete mixing, etc) and various types of portable utility equipment, such as compressors or generators.

9.1.2 Indoor Noise

Insofar as indoor noise is concerned, the noise could be due to the occupants themselves, which is transmitted from one room to the other. It could also be due to public functions and late night use of restaurants located in the hotel, as also due to miscellaneous utility equipment installed for providing and maintaining the services in the hotel, such as air-conditioning equipment, pumping equipment, power laundry and kitchen. Sometimes hotels equipped with standby generators are a potential source of noise. Another source which could lead to disturbance to the occupants is the plumbing system.

9.2 Recommendations

9.2.1 Site Planning

While it is desirable to locate the hotel, or hostel away from an area where there is a high ambient noise level, many a time these have to be located in noisy areas for public convenience. Hotels near airports and railway stations are becoming popular because they are convenient for passengers in transit. Hotels located in the commercial areas of a city are also a commercially viable proposition and many a time this factor outweighs the other problems associated with such a location. When a reasonably quiet location is not possible, it is desirable that adequate measures be considered to provide a comfortable acoustical environment for the occupants.

9.2.2 Internal Planning

Where a hotel is located in a noisy environment, the provision of sealed windows (single or double) and provision of an air conditioning system is desirable for rooms exposed to noise. The requirements for the windows would of course depend upon the level and character of noise in the area.

The general recommendations for satisfactory acoustical design of hotels and hostels are given in **9.2.2.1** to **9.2.2.7**.

9.2.2.1 Hotels of all classes shall by necessity provide good protection against indoor noise. Since hotels can be considered as flats, the standards of protection recommended for flats are also applicable to hotels. Partition between guest rooms and between rooms, corridors and floors shall not be less than 230 mm brick wall plastered or equivalent ($R_w = 50$ dB). The floors shall have proper impact insulation. Special attention should be paid to built-in wall cupboards as these are potential areas of sound leakage. These will not serve as sound insulating partitions and may not be

relied upon to increase the insulation value of partitions against which they may be built. In fact, partitions between adjoining rooms should be continuous behind the cupboards. Use of silent type door gear and cupboard catches is also highly desirable.

9.2.2.2 Door openings on opposite sides of corridors shall be staggered and doors shall be provided with gaskets on head, sides and threshold. Inter-communicating doors should be double doors, fully gasketed. Doors should also have quiet action latches. Whenever possible, rooms should be entered through a baffle lobby. Wherever possible, corridor walls should not have ventilators unless they are double glazed and non-openable.

9.2.2.3 Corridors and staircases may have resilient floor coverings and sound absorbent ceilings are desirable unless the corridor is fully carpeted. Staircases and lift wells may be cut off from corridors by means of swing doors and, if possible, isolated from guest rooms by linen stores or similar rooms. Room service pantries on floors can also be a source of noise and may be separated from corridors by baffle lobbies, unless the rooms themselves have baffle lobbies.

9.2.2.4 Except within the same suite, bathrooms should not be planned next to bedrooms. Where this is unavoidable, internal pipe shafts with heavy walls, unpierced on bedrooms side may be used as means of separation. It is important to choose quiet type of sanitary fittings and to design the plumbing system so as not to create noise, that is, by avoiding sharp bends, restrictions of flow, quick-action valves that might cause water hammer, etc.

9.2.2.5 Air-conditioning system should be quiet in operation. Care should also be taken that the air-conditioning ducts do not lead to a cross-talk problem between rooms. Suitable acoustical lining should be provided in the ducts consistent with the fire safety requirements of the buildings.

9.2.2.6 Large hotels often have banquet halls and conference halls which are separately hired out for public and private functions. Late night restaurants and night clubs are also popular and functions in all these areas may go on well into the night. It is therefore essential that these rooms be effectively isolated from bedrooms and effective insulation from all possible noise sources is considered. Here it is not only necessary to consider the air-borne sound insulation but it is also necessary to consider the question of structure-borne and impact noise transmitted from areas where there might be dancing late into the night. Floating floors may be considered for structure borne sound isolation for dance floors and loudspeakers.

9.2.2.7 While most of the noise problems encountered in hotels are applicable to hostels, the latter are normally of more economical construction and, therefore, cannot cater for special sound insulation provisions. However, as far as possible, precautions should be taken to provide comfortable conditions in hostel rooms. This is especially true for student hostels where each room is also a living room. Students might play music or have loud discussions late into the night.

This may disturb sleep or study of other students. Proper precautions should, therefore, be taken to provide satisfactory conditions.

10 INDUSTRIAL BUILDINGS

10.1 General

Industrial buildings are primarily producers rather than receivers of noise. The level of industrial noise commonly exceeds that from any other source with the exception of aircraft. As compared with traffic noise, its effects are less widespread but it is often more annoying in character.

10.1.1 Many industrial noises contain very strong high frequency whines, screeches and clatter - these components are relatively more attenuated by passage through the air and by the insulation of light structure than are lower frequencies.

10.1.2 Intermittent noises are either isolated explosions or reports, or noises of a periodic nature, such as those of pressure relief valves of blow off, or the noises of work occurring at random intervals, for example, hammering, grinding and sawing operations; the latter class may be especially irritating because of high frequency components.

10.2 Sources of Industrial Noise

10.2.1 Noises in industrial buildings are mainly of indoor origin. Noise in factories and workshops is generally caused by machine tools and by operations involved in making and handling the product and they are classified into the following groups, depending upon how the noise energy is generated.

10.2.1.1 *Impact*

Noise caused by impact is the most intense and widespread of all industrial noises. It is normally coupled with resonant response of the structural members connected to the impacting surface. Common sources of this type of noise are forging, riveting, chipping, pressing, tumbling, cutting, weaving, etc. Intense impact noise may also be produced during handling of materials as in the case of sheared steel plates falling one over another in collecting trays in a steel factory. Impact noise is usually intermittent and impulsive in character, but it may also be continuous as in the case of tumbling.

10.2.1.2 *Friction*

Most of the noise due to friction is produced in such processes as sawing, grinding and sanding. Friction also occurs at the cutting edge on lathes and other machine tools and in brakes and from bearings. The spectrum of frictional noise often predominates in high frequency and is very unpleasant in character.

10.2.1.3 *Rotation and reciprocation*

A rotating or reciprocating machine generates noise due to unbalanced forces and/or pressure fluctuations in the fluids inside the machines. In many cases, the moving surfaces radiate noise directly and in other cases, the pressure fluctuations are transmitted to the outer casings of the machine from where they are radiated as noise.

Interaction of rotating component with the fluid stream can also give rise to pure tone components, such as the whine in a turbine. Since most machine casings have radiation efficiencies of unity in the higher frequency range, the amount of sound radiated is often substantial.

10.2.1.4 Air turbulence

Noise may be generated by rapid variation in air pressure caused by turbulence from high velocity air, steam or gases. Common examples are the exhaust noise from pneumatic tools and air jets. The noise is intense, and broad based in character and the frequency criteria depends on the size of the jet. The intensity increases rapidly with the velocity of the air stream.

10.2.1.5 Noises with pure tone components

Whining noise from turbines and humming noise from transformers come under this group.

10.3 Noise Criteria

10.3.1 Hearing Damage – Risk Criteria

Continuous exposure to high noise levels may result in permanent noise induced hearing loss in the course of time. Damage-risk criteria specify the maximum levels and duration of noise exposure that may be considered safe. Generally accepted damage-risk criteria for exposure to continuous, steady broad band noise are shown in Table 7. Whenever the sound levels at the workers position in a factory exceed the levels and the duration suggested, feasible engineering controls shall be utilized to reduce the sound to the limits shown. If such controls fail to reduce sound levels within the levels of Table 7, personal hearing protection equipment shall be provided and used to reduce sound levels within the level shown.

Table 7 Permissible Exposure Limits for Steady-State Noise
(Clause 10.3.1)

SI No.	Sound Level (Slow Response) dBA	Time Permitted, T h : min
(1)	(2)	(3)
i)	85	16:00
ii)	86	13:56
iii)	87	12:08
iv)	88	10:34
v)	89	9:11
vi)	90	8:00
vii)	91	6:58
viii)	92	6:04
ix)	93	5:17
x)	94	4:36

xi)	95	4:00
xii)	96	3:29
xiii)	97	3:02
xiv)	98	2:50
xv)	99	2:15
xvi)	100	2:00
xvii)	101	1:44
xviii)	102	1:31
xix)	103	1:19
xx)	104	1:09
xxi)	105	1:00
xxii)	106	0:52
xxiii)	107	0:46
xxiv)	108	0:40
xxv)	109	0:34
xxvi)	110	0:30
xxvii)	111	0:26
xxviii)	112	0:23
xxix)	113	0:20
xxx)	114	0:17
xxx)	115	0:15

NOTES

- 1 Where the table does not reflect the actual exposure times and levels, the permissible exposure to continuous noise at a single level shall not exceed the time T (in h) computed from the formula:

$$T = \frac{16}{2^{[0.2(L-85)]}}$$

where

L = work place sound level measured in dBA.

- 2 When the daily noise exposure is composed of two or more periods of different levels, their combined effect should be considered rather than the individual effect of each. The combined levels may not exceed a daily noise dose, D of unity where D is computed from the formula:

$$D = \frac{C_1}{T_1} + \frac{C_2}{T_2} + \dots + \frac{C_n}{T_n}$$

where, C_1, C_2, \dots, C_n indicate the total duration of exposure (in hour) at a given steady-state noise level; and T_1, T_2, \dots, T_n are the noise exposure limits (in hour for the respective levels given in the table or computed by the equation in Note 1. Exposure to continuous noise shall not exceed 115 dBA regardless of any value computed by the formula for the daily noise dose, D or by the equation in Note 2.

10.3.2 Interference with Communication

In factories where audible warning signals are used, or where an operator follows the operation of his machine by ear, the background noise should not be so loud as to mask the signal or desired sound (the information sound) to be heard. Noise may be the cause of accidents by hindering communication or by masking warning signals.

10.4 Methods of Reducing Noise

10.4.1 Noise Control by Location

Machines, processes and work areas which are approximately equally noisy should be located together as far as possible. Areas that are particularly noisy should be segregated from quiet areas by buffer zones that produce and may tolerate intermediate noise levels.

10.4.2 Noise Reduction by Layout

The office space in a factory should be as far as possible located preferably in a separate building. This building should not have a wall common with the production area. Where a common wall is unavoidable, it should be heavy with few connecting doors and no permanent openings.

10.4.3 Noise Reduction at Source

10.4.3.1 Selection of machinery

Noise should be reduced as near the source as possible. While the operational processes in a factory may be fixed and may have no quieter alternative, careful selection of the machine tools and equipment to be used may considerably help attaining lower noise levels in the machine shop.

10.4.3.2 Reducing noise from potential sources

Impact that is not essential to a process should be quietened. Noise from handling and dropping of materials on hard surface may be reduced by using soft resilient materials on containers, fixing rubber tyres on trucks, trolleys, etc. Machine noise may be kept to a minimum by proper maintenance. Proper lubrication reduces noise by friction conveyors, rollers, etc.

10.4.3.3 The noise from the radiating surfaces may be reduced by reducing the radiating area. For example, if the area is halved, the noise intensity will be reduced by 3 dB and at low frequencies the reduction will be much greater.

10.4.3.4 Supporting structures for vibrating machines and other equipment should be frames rather than cabinets or sheeted enclosures. If an enclosure is used, precaution should be taken to isolate it and line it on the inside with sound-absorbent material. Penetration through the enclosure should be adequately sealed. The noise radiated by machinery guards can be minimised by making them of perforated sheet or of wire mesh.

10.4.3.5 Reducing transmission of mechanical vibration

A vibrating source does not usually contain a large radiating surface but the vibration is conducted along mechanically rigid paths to surfaces that can act as effective radiator. If the rigid connecting paths are interrupted by resilient materials, the transmission of vibration and consequently the noise radiated may be greatly reduced. The reduction depends on the ratio of the driving (forcing) frequency of the source to the natural frequency of the resilient system. The natural frequency may be determined from static deflection under actual load as given in Fig. 1. The higher the ratio between the two frequencies, the lesser is the transmissibility, which is defined as the ratio of the force transmitted through the resilient isolator to the exciting force applied to it. Transmissibility and the equivalent noise reduction for various frequency ratios are given in Fig. 2. For satisfactory operation, a ratio of 3 : 1 or more between the driving and natural frequencies is recommended.

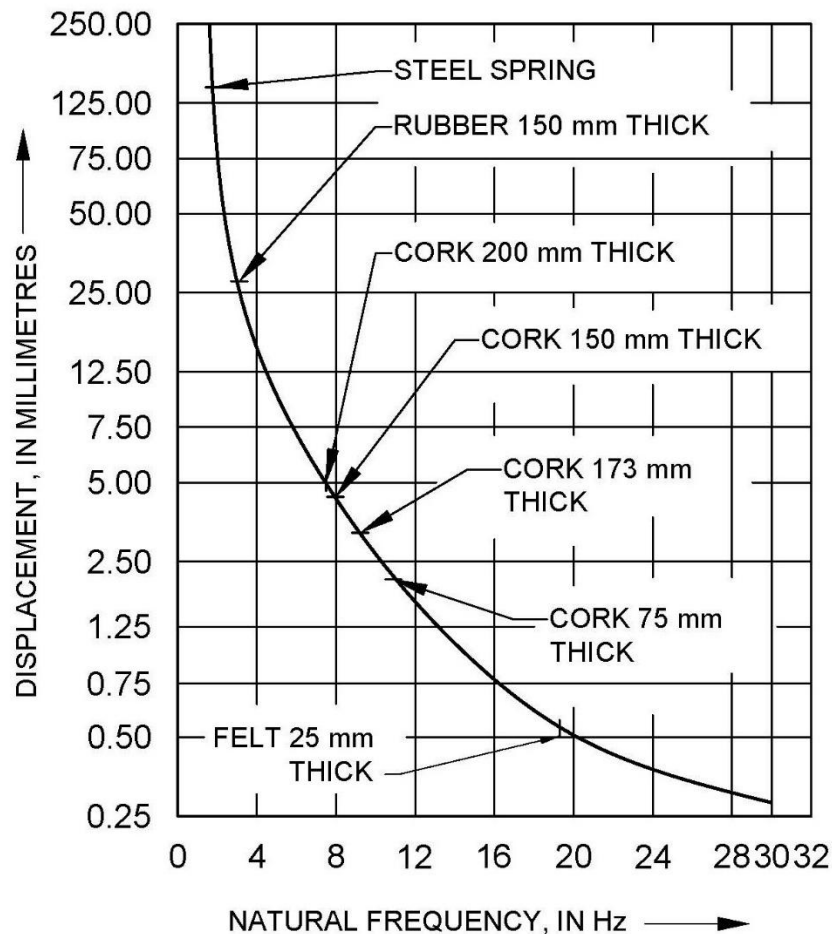

FIG. 1 RELATION BETWEEN STATIC DEFLECTION AND NATURAL FREQUENCY

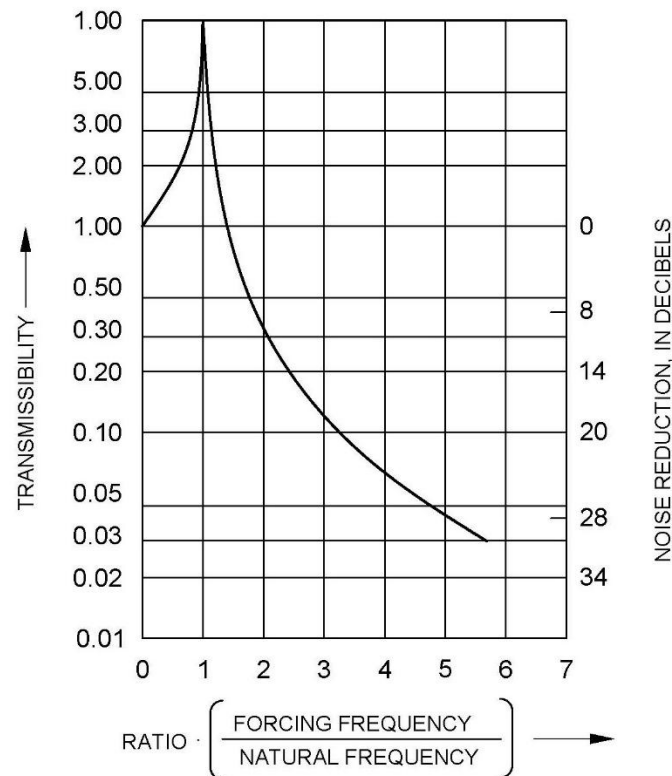

FIG. 2 TRANSMISSIBILITY AND EQUIVALENT NOISE REDUCTION FOR DIFFERENT RATIOS OF FORCING AND NATURAL FREQUENCIES

Materials for isolators and their position are given below:

- a) *Material for Isolators* – Vibration isolators are usually made of resilient materials like steel in the form of springs and rubber.
- 1) Because of the large range of deflections obtainable in coil springs, they may isolate vibrations over a large spectrum of low frequencies. Metal springs transmit high frequency (from about two hundred to several thousand c/s) very readily. Transmission of these frequencies can be reduced by eliminating direct contact between the spring and the supporting structure. Rubber or felt pads may be inserted between the ends of the spring and the surfaces to which it is fastened.
 - 2) Rubber in the form of pads may be used to isolate very effectively engines, motors, etc. It may be used in compression or in shear. Some rubber mountings use rubber-in-shear as the primary elastic elements and rubber-in-compression as a secondary element which furnishes snubbing action if the mounting is subjected to an overload.
 - 3) Felt or cork or both may be used as resilient mats or pads under machine bases. The load per unit area shall be chosen to produce enough deflection for the isolation required; and shall be such that at this deflection, it is not loaded beyond its elastic limit.

- b) *Position of Isolators* – The normal position of the isolators is between the machine and its foundation. However, if the forcing frequency of the machine is low (less than 10 Hz) and vibration isolators with the requisite deflection for this location are not available, the machine may be bolted directly to an independent heavy inertia concrete base and the available vibration isolators used below the concrete base.
- 1) Large press and drop hammers which create serious impact vibration in heavy machine shops may be mounted rigidly on very massive blocks of concrete having weights several times greater than the weights of the supported machines. The inertia blocks may, in turn, be isolated from the building structure by large wooden blocks and with thick pads of cork.
 - 2) In critical installations (see Note), attempt should be made to locate the resilient mounts in a plane which contains the centre of gravity of the mounted assembly. It is also preferable to locate the mounts laterally as far away as possible from the centre of the machine.

NOTE – Critical installations are those installations where transmission of vibration from these installations seriously hamper the normal working.

- 3) Rigid mechanical ties between vibrating machine and building structure, short-circuit or reduce the effectiveness of isolators. Loose and flexible connections should be inserted in all pipes and conduits leading from the vibrating machine. Where flexible connections are impracticable, bends should be inserted into the pipes or the pipes themselves should be supported on vibration mounts for a considerable distance from the source.
- 4) *Flexibility of foundation* – The effect of flexibility of the foundation on the isolator transmissibility shall be considered in the selection of practical vibration isolating mountings. The simplified vibration isolation theory assumes a completely rigid foundation. However, in practice, this can never be achieved. The foundation is never actually completely rigid. Generally, the relatively low stiffness of the isolation system permits the assumption of the foundation to be rigid. However, if the stiffness of the isolator is allowed to become comparable to the foundation stiffness (or greater), the deflection of the isolator will become smaller and the foundation will also deflect with increased transmissibility and decreased isolator efficiency. In a dynamic sense, supporting foundation or floors should have natural frequency as high and be as stiff as possible compared to the system being isolated. Good design practice requires that the isolators should be designed assuming a rigid foundation with the stipulation that the selected machine isolation system frequency should be well below the foundation frequency. This point should specially be kept in mind when installing machines at upper levels in buildings because supported slabs generally have lower natural frequencies (low stiffness) than slabs on grade in basement or ground floor locations.

10.4.4 Noise Reduction by Enclosures and Barriers

10.4.4.1 Enclosures

Airborne noise generated by a machine may be reduced by placing the machine in an enclosure or behind a barrier. The enclosure may be in the form of close-fitting acoustic box around the machine such that the operator performs his normal work outside the box and thus is not subjected to the high noise levels of the machine. The enclosure may be made of sheet metal lined inside with an acoustical material.

Where size of the machine, working area and the operation do not permit close-fitting enclosures, the machine may be housed in a room of its own. The inside of the enclosure should be lined with sound-absorbing materials to reduce the noise level of the contained sound. The bounding walls of the enclosures shall also have adequate transmission loss to provide desired noise reduction.

10.4.4.2 Barriers

A partial reduction of noise in certain directions may be obtained by barriers or partial enclosures or partial height walls. Two-sided or three-sided barrier, with or without a top and invariably covered on the machine side with acoustic absorption material should face a wall covered with sound-absorbing material. If the top of the enclosure is open, the reduction may be increased by placing sound-absorbing material on the ceiling overhead.

10.4.5 Acoustical Absorption Devices

10.4.5.1 Acoustical treatment of ceilings and side walls

In order to reduce the general reverberant noise level in machine shops, acoustical material may be provided on as much of the available area on the ceiling and side walls. With this treatment 3 to 6 dB reduction of middle and high frequency noise may be achieved. While the noise level at the source, affecting the operator, may not be reduced materially, the treatment would bring down the built-up noise level away from the source in reverberant field.

10.4.5.2 Functional sound absorbers

For efficient noise reduction functional sound absorbers may be clustered as near the machines as possible. These units may be suspended and distributed in any pattern to obtain lower noise levels within the machine shop. Compared on the basis of equal total exposed surface areas, functional sound absorbers have higher noise reduction coefficients (NRC) than conventional acoustical materials placed directly on ceilings and walls.

10.5 Noise Control in Specific Industrial Occupancies

10.5.1 Manufacturing and Heavy Machinery Industries

10.5.1.1 Industrial units with high-noise equipment such as stamping presses, crushers, and rolling mills shall install vibration isolation platforms or resilient mounts to control structure-borne noise.

10.5.1.2 Machines producing significant noise shall be enclosed in acoustic enclosures to prevent noise propagation within the facility and reduce exposure to workers.

10.5.1.3 Partition walls between noisy production areas and quieter zones (such as offices or break rooms) shall incorporate sound-insulating materials or be designed with adequate thickness to ensure minimal noise transfer.

10.5.2 Chemical and Pharmaceutical Plants

10.5.2.1 Noise-generating equipment such as pumps, compressors, and centrifuges shall be fitted with mufflers or acoustic casings to minimize sound emissions.

10.5.2.2 Mechanical rooms containing HVAC systems and other service units shall be acoustically treated and isolated from production spaces to prevent noise transmission.

10.5.2.3 Noise-sensitive spaces such as laboratories and quality control areas should either be located away from noisy zones or separated by floating floors or soundproof partitions to ensure operational efficiency.

10.5.3 Food Processing Units

10.5.3.1 Equipment such as blenders, grinders, and packaging machines shall use vibration-isolating mounts to control structure-borne noise.

10.5.3.2 Temporary sound barriers may be installed around seasonal operations like bulk-loading zones during periods of high activity.

10.5.3.3 Control rooms and staff areas shall be acoustically insulated to ensure noise relief, with soundproof partitions and doors installed where necessary.

10.5.4 Power Plants and Utilities

10.5.4.1 Power plants shall install noise barriers or walls around high-noise zones such as turbine halls and generator rooms to minimize sound emissions beyond facility boundaries.

10.5.4.2 Cooling towers and exhaust stacks shall be equipped with noise control devices like silencers to mitigate low-frequency noise emissions.

10.5.4.3 Control rooms and operational centres shall be designed to maintain appropriate noise levels conducive to work, with double-wall partitions or air gaps considered for turbine or engine rooms.

11 LABORATORIES AND TEST HOUSES

11.1 Sources of Noise

11.1.1 Outdoor Noise

In a test house or laboratory, where research workers and scientists are engaged in performing sophisticated experiments, the external noise is mostly contributed by noise emitting buildings (workshops, machine rooms), airports, railway stations and general traffic noises. The outdoor sources of noise in a college laboratory include noises produced in a playground as well.

11.1.2 Indoor Noise

The following sources mainly contribute to indoor noises in research institutions/college laboratories:

- a) Workshops, machine rooms, cafeteria, etc;
- b) Air conditioning and exhaust fans;
- c) Noise produced within the test house or laboratory while performing experiments; and
- d) Typing or other machine noises, telephone service, lift, sanitary services, etc.

11.2 Recommendations

11.2.1 Site Planning

While planning for a laboratory or test house, care should be taken in the design that no noise emitting installations should exist in its neighbourhood. However, where outdoor noises exist, such as from local factory, heavy traffic airports, railway lines, sport grounds or busy markets, buildings should be kept as far away as possible from the source of noise.

11.2.1.1 The window and door openings towards the noise sources should be minimum. Minimum amount of glazing should be placed on walls directly facing the noise sources.

11.2.2 Internal Planning

11.2.2.1 Noisy places should be kept separate from the quiet ones. The location of laboratories or test houses should be so chosen that it is cut off from the noisy zones. Where there are offices attached to a laboratory, provision should be made to treat

the offices and to use acoustical partitions, to achieve a sound isolation D_w of at least 35 dB.

11.2.2.2 In a laboratory, mostly hard reflecting surfaces and bare furnishings are found, which produce very reverberant conditions. The noise condition still deteriorates when noise producing instruments are switched on or a heavy object is dropped on the floor. Under these conditions, sound absorbing treatment of the space is very essential. Sound absorbing ceilings are recommended to deaden such noises. Rubber buffers may also be fitted to the legs of furniture.

11.2.2.3 In large span laboratories or test houses where scientists and researchers are engaged in work and/or simultaneously busy in calculations or desk work requiring high degree of mental concentration, use of sound absorbing screens is recommended.

11.2.2.4 Noise reduction between the test house or laboratory and corridors or general circulation space should be well kept in mind and due care should be taken of the type of doors and the manner of their fittings, etc. Transmission of noise through service ducts, pipes, lifts and staircases should also be guarded.

Telephones should preferably be placed in a separate small enclosure or acoustically efficient telephone booth.

11.2.2.5 To isolate a laboratory or a test house from structure-borne noises originating from upper floor, sandwich type floor construction is recommended.

11.2.2.6 Wherever the provision of double glazed windows is necessary to reduce the heat losses, care should be taken to provide sealed double windows rather than double glazing in a single window.

NOTE – Double glazed windows for sound insulation should have a minimum gap of 100 mm between the two glasses.

12 MISCELLANEOUS BUILDINGS

12.1 Law Courts and Council Chambers

It is important that law courts and council chambers be protected from the intrusion of outdoor noise and from indoor noise arising both from ancillary offices and circulation spaces. The general recommendations on site planning given in **3** apply to law courts and municipal buildings, but in the larger buildings at least, further protection against outdoor noise can be obtained by planning offices and other rooms around the court rooms or chambers, and separating the offices from the central rooms by means of corridors. This arrangement is usually convenient to the function of the buildings.

12.1.1 The wall between the corridors and the central rooms should have a sound reduction index, R_w of not less than 50 dB (for example 230 mm brick) to insulate against airborne noise in the corridors. Entrances from halls or corridors into court rooms or council chambers should be through baffle lobbies with two sets of quiet

action doors. Sound absorbing treatment on ceilings and upper parts or walls or entrance lobbies is recommended.

12.1.2 The whole of the floor of the court room or chamber including steps and seating areas set aside for the public should have a resilient floor finish to reduce the noise of footsteps and shuffling of feet. Any tip-up seats should be quiet in action.

12.1.3 Sound absorbing treatment applied for acoustic purposes serves also to reduce the build-up of noise within the room. It is desirable to provide sound absorbing ceiling in the court room.

12.2 Libraries, Museums and Art Galleries

Quiet conditions for reading and study are essential in these types of buildings and, since their occupancy is not noise producing, intruding noise is more noticeable and distracting. Every opportunity therefore should be taken to plan for noise defence, both in respect of siting of the building and internal planning. When possible, stack rooms, store rooms and administrative offices should be planned to screen reading rooms, print rooms and lecture rooms from noise sources. In public libraries, the reference library and lecture rooms should receive first consideration; the lending library, newspaper and periodical rooms have a higher background noise and are secondary in importance.

12.2.1 In large libraries, museums and art galleries echoes from lofty, large domed or concave ceilings are often a nuisance. Small noises such as footsteps, coughs, chair scraping and closing of books are reinforced by reverberation, and concave surfaces even when treated with a sound absorbent may focus these noises. Treated flat ceilings, if not too high, obviate these troubles. Books on shelves in libraries constitute a valuable wall absorbent.

12.2.2 Floor finishes are important. The impact noise of footsteps on marble, terrazzo or wood block flooring, and especially on hardwood strip and batten flooring, can be disturbing both within the room in which the noise is generated and the rooms below. On solid floors, resilient floor finishes, such as rubber, cork and linoleum on an underlay, are highly desirable. In the children's sections of libraries and museums they are essential. In existing buildings, rubber linoleum or vinyl asbestos tiles laid over the floor in the traffic areas are often a solution to the problem.

12.2.3 Reference libraries in universities, research establishments, office buildings and science buildings having machines and testing benches, should be planned in a quiet part of the building. Walls enclosing the library should normally have a sound reduction index, R_w of not less than 50 dB (for example 230 mm brick) and baffle lobbies should be planned between the library and halls and corridors. Walls facing on to corridors or other noisy areas should not have fanlights unless they are double glazed and non-operable.

12.3 Auditoria and Theatres

The sources of noise that have to be considered in concert halls, opera house, theatres and similar auditorium buildings are as follows:

- a) Outdoor noise entering through walls, roofs, doors, windows or ventilation openings;
- b) Noise from any other hall in the same building, especially if let out separately for revenue;
- c) Noise from foyers, service rooms and other ancillary rooms, particularly rehearsal rooms;
- d) Noise from air conditioning plant, etc, and the cross-transmission of other internal noises via ventilating duct system; and
- e) Impact generated noise due to rainfall on light weight metal roofs.

12.3.1 Because of greatly increased outdoor noise, all auditorium buildings now need more care in siting than formerly. For listening to speech or music, a very low background noise level is desirable; in concert halls especially, the quietest possible conditions should be provided because the pauses and moments of silence which are an essential element of music cannot otherwise be given full value. Therefore, sites at cross-roads or close to steel railway bridges, religious places or near churches where bell ringing is practiced, should be avoided unless very high standards of structural sound insulation are contemplated. Sites adjoining underground railways may also prove unsatisfactory at basement levels owing to low-pitched noise or rumble transmitted through the ground; special isolation measure need to be adopted for isolating large buildings from ground vibration of this sort.

12.3.2 Whenever possible, for concert halls and theatres on city sites a noise survey of the site should be made; a suitable sound reduction value for the structure of the building can then be chosen so as to keep down to certain maximum noise levels within the auditorium. The maximum octave-band sound pressure levels (SPL) recommended are given in Table 8.

**Table 8 Maximum Sound Pressure Levels Due to
External and Mechanical Equipment Noise in Auditoria (dB)**
(Clause 12.3.2)

Sl No.	Type of Auditorium	Centre Frequency Hz							
		63 (3)	125 (4)	250 (5)	500 (6)	1 000 (7)	2 000 (8)	4 000 (9)	8 000 (10)
i)	Concert halls [dBA-25]	51	39	31	24	20	17	14	13
ii)	Drama Theatres and Cinemas [dBA-30]	55	44	35	29	25	22	20	18

12.3.3 The minimum standard of sound reduction index, R_w likely to be required for the envelope of an auditorium in a city to protect it against external noise is of the order of 65 dB for a concert hall or 55-60 dB for a theatre. This reduction should be provided on all sides, but it would be reasonable to make the R_w for the roof 5 to 10 dB less

provided the building is not unduly exposed to noise from aircraft in flight. Surrounding the auditorium with ancillary rooms and foyers is an obvious and invaluable planning method of obtaining the required insulation against outdoor noise.

12.3.4 Ventilation intakes and returns are vulnerable features in the defence against external noise. They should be positioned so as to avoid exposure to noise, and in addition sufficient length of both inlet and outlet ducts should be provided with carefully designed silencers. The ventilation system should also be designed to avoid transmitting or adding to internal noise.

12.3.5 The most serious internal noise problem arises when there are two halls meant for separate use in the same building, especially if one of them is a concert hall. The latter is a very loud potential source of noise and requires a high standard of protection against extraneous noise. In these circumstances it is doubtful whether a 'single' wall can be adequate for insulating the two halls unless it is designed with a wide unbridged cavity. Separation by planning is preferable.

12.3.6 Other sources of internal noise are rehearsal rooms, scenery bays and workshops, stages of other halls where rehearsals or erection of stage sets might be in progress and foyers and bars where loud conversation might occur. The insulation of the internal walls should be adequate to protect the auditorium from these noise sources and the insulation should not be by-passed by openings, doorways, etc. The general noise due to banging of doors also needs to be taken care of; soft sealing materials should be provided for all doors to ensure quiet closing.

12.3.7 Mechanical equipment such as lifts shall be effectively isolated from the building structure to help avoid noise transmission.

12.3.8 Adequate damping shall be provided under light weight metal roofs with an additional light weight under deck noise sound barrier to reduce rainfall generated noise.

12.3.9 For detailed acoustical design of auditoria and conference halls reference may be made to good practice [8-4(3)].

12.4 Cinemas

The main objective of the design should be to control noise from adjacent screens, the projection area, the foyer, and outside the cinema. The first of these, controlling noise from adjacent screens, is likely to be the most difficult with modern digital sound systems. As most cinemas are air-conditioned, there will be some noise from services. To ensure reasonable listening conditions, this should be limited to 30 dBA. This will provide some masking of the noise from adjacent screens, but a high performance partition will still be essential. Masonry or lightweight construction may be used, and a typical performance specification for a lightweight wall separating two screens is given in Table 9. Cinema design, however, normally requires specialist acoustic advice.

**Table 9 Typical Sound Insulation Specification for Wall Separating
Two Cinema Screens**
(Clause 12.4)

SI No.	Octave band Hz	Sound Reduction Index, R dB
(1)	(2)	(3)
i)	63	38
ii)	125	44
iii)	250	50
iv)	500	61
v)	1 000	57
vi)	2 000	58
vii)	4 000	57
viii)	8 000	55

13 NOISE FROM BUILDING SERVICES

13.1 Mechanical, electrical, air conditioning, heating and mechanical ventilation, and other services are provided in almost all large buildings including residential, commercial and industrial buildings. Noise control measures should be incorporated during the design and installation of such services to adhere to the recommended outdoor and indoor noise criteria for the kind of occupancy. For detailed design of noise control for services, specialist advice should be sought.

Some basic design techniques for noise control in air conditioning, heating and mechanical ventilation system are given in Annex G.

13.2 Control of noise from mechanical equipment can also be done by specifying noise control requirements while purchasing the equipment (see Annex H).

14 NEIGHBOURHOOD ACOUSTIC SHIELDING DURING INFRASTRUCTURE DEVELOPMENT

14.1 General

Infrastructure development projects often generate substantial noise that can adversely affect the well-being of residents. Prolonged exposure to noise pollution may lead to health issues such as sleep disturbances, hearing impairments and stress. Hence, effective acoustic shielding of neighbourhood is required to minimize such impacts. The following clauses outline the provisions for noise control during infrastructure development.

14.2 Pre-Development Noise Assessment

14.2.1 A baseline noise assessment shall be conducted prior to the commencement of construction activities to determine ambient noise levels and identify noise-sensitive receptors (NSRs), including residential areas, schools, and healthcare facilities.

14.2.2 Noise modelling should be performed to predict noise levels for each phase of construction. The model shall take into account equipment type, frequency and duration of activities, and the topography of the site.

14.2.3 Predicted noise levels shall be compared with the limits prescribed. If expected levels exceed the permissible limits, additional mitigation measures shall be proposed.

14.3 Noise Mitigation Planning

14.3.1 A noise mitigation plan (NMP) shall be prepared prior to the commencement of any construction work. The NMP shall include:

- a) Identification of potential noise sources and their expected noise levels,
- b) Location of noise-sensitive receptors and baseline noise levels,
- c) Proposed noise control measures and their implementation timelines,
- d) Monitoring strategies for continuous noise assessment, and
- e) Community engagement strategies and complaint management procedures.

14.3.2 Construction activities that generate high levels of noise shall be scheduled during permissible hours. Noise-intensive operations shall be avoided during night time hours unless specific approval is obtained.

14.4 Noise Barriers

14.4.1 Temporary noise barriers shall be installed at the perimeter of construction sites to shield NSRs from construction noise. Barriers shall be designed to achieve a minimum noise reduction of 10 dBA. The height of the barriers shall be at least 2.5 m or as determined by site-specific acoustic analysis.

14.4.2 Permanent noise barriers, such as earth berms, concrete walls, or vegetative buffers, may be considered for long-term infrastructure projects with expected noise impacts exceeding permissible limits.

14.4.3 Recommended guidelines for the design and performance evaluation of noise barriers are given in Annex K.

14.5 Low-Noise Equipment and Practices

14.5.1 Low-noise equipment, such as electric or hydraulic machinery, shall be used wherever feasible. Equipment should be fitted with silencers, mufflers, or acoustic enclosures to reduce emissions.

14.5.2 Construction techniques that minimize noise generation, such as hydraulic splitting instead of pneumatic hammering for concrete demolition, shall be employed wherever possible.

14.6 Maintenance of Equipment

14.6.1 A maintenance schedule for all construction equipment shall be implemented to ensure optimal operating conditions and minimize noise emissions.

14.6.2 All equipment shall be inspected regularly for defects, such as worn-out parts, loose fittings, or damaged mufflers, that may increase noise levels. Defective equipment shall be repaired or replaced immediately.

14.7 Noise Monitoring and Compliance

14.7.1 Continuous noise monitoring shall be conducted at designated locations near NSRs throughout the construction period. Monitoring equipment shall be as per accepted standard [8-4(5)].

14.7.2 Noise levels shall be logged at regular intervals. The logged data shall be reviewed daily to ensure compliance with the permissible noise levels.

14.7.3 If noise levels exceed permissible limits, corrective actions, such as modifying work practices, deploying additional noise barriers, shall be implemented within 24 h.

14.7.4 A noise monitoring report shall be maintained throughout the project, including logged data, incidents of exceedances, corrective actions taken, and community complaints received.

14.8 Community Engagement and Communication

14.8.1 A community noise management plan should be established as part of the NMP, outlining strategies for engaging with the local community, informing them about construction activities, expected noise impacts, and mitigation measures.

14.8.2 A public contact point shall be established for residents to report noise concerns. All complaints should be logged, investigated, and resolved promptly.

14.9 Vegetative Buffers

14.9.1 Where feasible, vegetative buffers consisting of dense rows of trees or shrubs shall be planted around the construction site to serve as supplementary noise barriers.

14.9.2 Vegetative buffers should have a minimum width of 5 m and be composed of mixed species with dense foliage for optimal sound absorption.

14.10 Post-Construction Noise Assessment

14.10.1 Upon completion of construction activities, a post-construction noise assessment shall be conducted to verify that ambient noise levels have returned to pre-development conditions or meet permissible limits.

14.10.2 Temporary noise barriers shall be dismantled and disposed of responsibly. If permanent barriers or vegetative buffers were installed, they shall be integrated into the final landscape design.

15 TRAFFIC NOISE BARRIERS

Noise barriers are one of the most effective ways to mitigate road traffic noise. Noise barriers can reduce the A-weighted noise levels depending on their design and height. If the barrier surface density exceeds 20 kg/m^2 , a reduction of 5 dB can be achieved by having a barrier tall enough to break the line of sight from the road to the receiver and an additional 1.5 dB reduction can be achieved for each additional meter of height. The efficiency of noise barrier largely depends upon its geometry. Besides the height of the barrier and its top element form, the cross section of the barrier contributes to its performance well. Recommended guidelines for the design and performance evaluation of noise barriers are given in Annex K.

ANNEX A
(Clause 2.4)**NOISE CALCULATIONS****A-1 GENERAL**

Some of the simpler types of noise calculation are described in this annex.

A-2 ADDITION OF TWO NOISE LEVELS

To determine the combined sound pressure level (L_c) resulting from the sound pressure levels of two or more noise sources (L_1 , L_2 , etc), it is necessary to calculate and add the mean square values of their individual sound pressures and then convert this back to a sound pressure level. This can be done using the following formula:

$$L_c = 10 \log_{10} (10^{L_1/10} + 10^{L_2/10})$$

As the individual sound pressure levels are logarithms of the mean square sound pressures, they cannot simply be added arithmetically. Figure 3 shows a graphical method for adding the sound pressure levels from two independent sources to obtain the combined sound pressure level at a particular place. This graph may also be used for multiple sources by combining sources two at a time to produce virtual sources that can then be combined. The most accurate approach is to start with the lowest levels and work towards the highest.

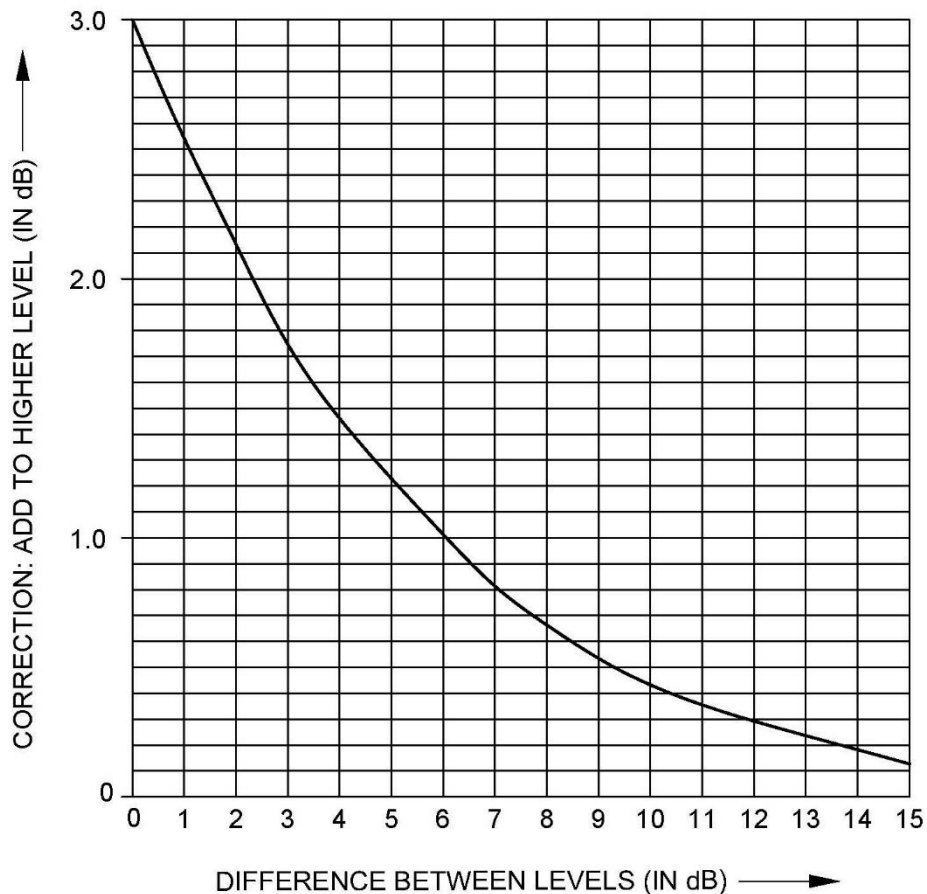

FIG. 3 ADDITION OF TWO NOISE LEVELS

The graph should be used with caution where the noise sources are not independent. For example, the sound pressure level from two large transformers fed with currents in phase will be very sensitive to the receiving position. This is because the effect of the constructive and destructive interference of the sounds from the two sources is very dependent on position.

A-3 SUBTRACTION OF TWO NOISE LEVELS

When measuring noise from a source, the true noise level of the source alone will be less than that shown by the meter if the level of extraneous noise is less than about 10 dB below the total noise level. An estimate of the true source level can be obtained from Fig. 4.

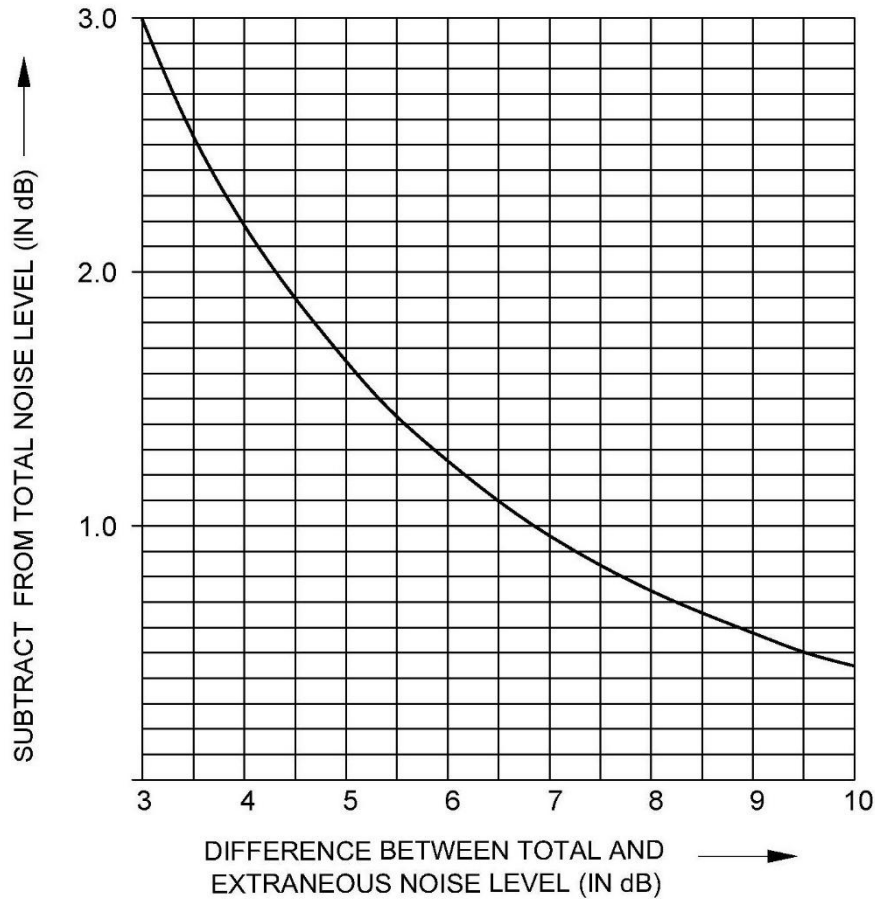

FIG. 4 SUBTRACTION OF NOISE LEVELS

A-4 NON-UNIFORM COMPOSITE PARTITIONS

Figure 5 provides for calculating the overall sound insulation of a composite partition consisting of two parts having different sound-insulating properties, for example, a window in a wall. It may also be used to give an indication of the effect of gaps or holes in a partition by assigning a sound insulation value of 0 dB to the aperture.

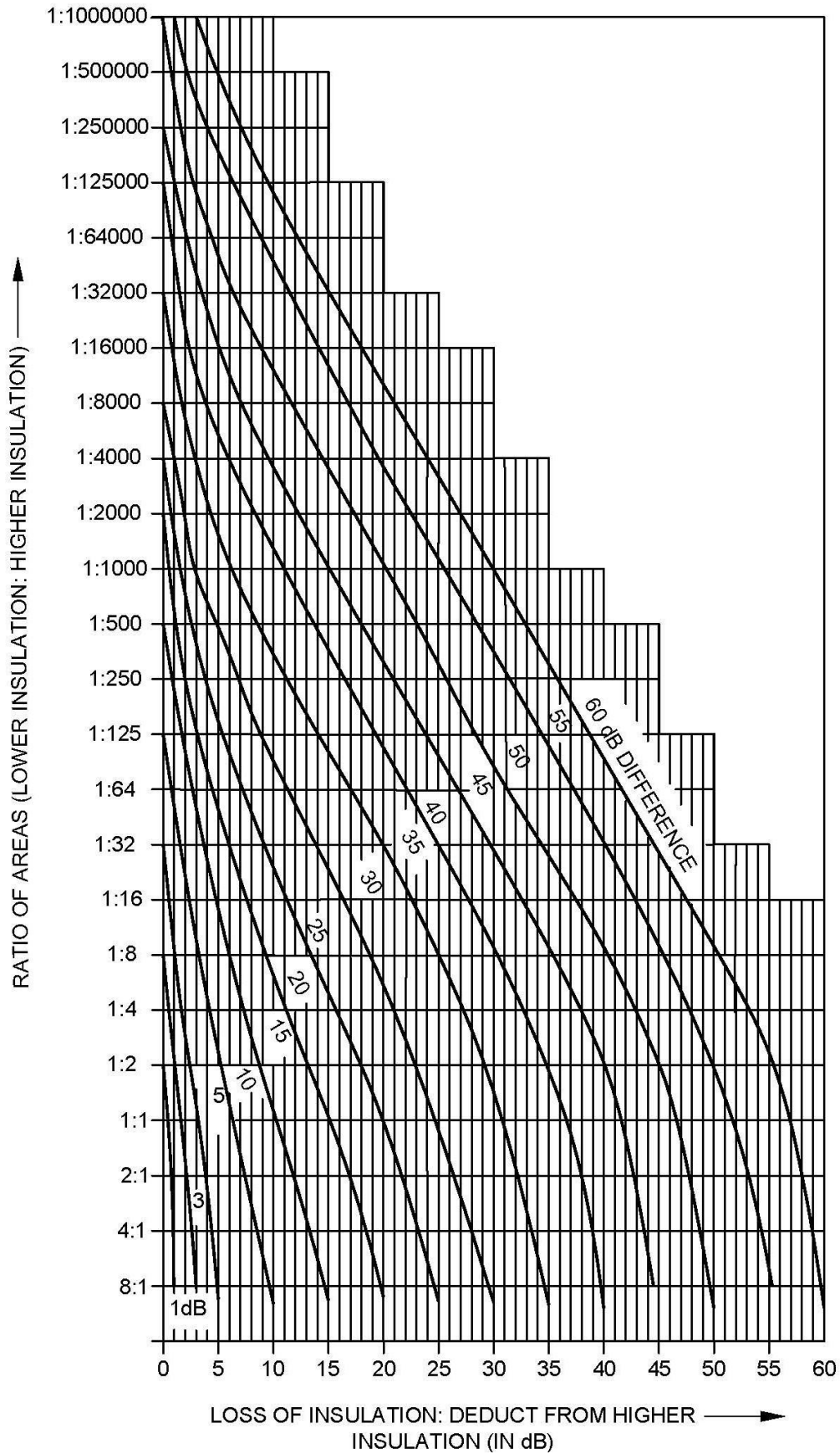

FIG. 5 SOUND INSULATION OF NON-UNIFORM PARTITIONS

A-5 A-WEIGHTING CALCULATIONS

The equivalent A-weighted level is often required when data on a noise source is available as a set of octave band or one-third octave band levels. The conversion can be done manually, using the standard A-weighting values (see Table 10) and the graph for combining levels (see Fig. 3). For all but the simplest situations it is more convenient to use a computer spreadsheet to do the conversion.

Table 10 Standard A-Weighting Values (dB)
(Clause A-5)

SI No.	Third Octave Band Centre Frequency Hz	A-Weighting dB	Third Octave Band Centre Frequency Hz	A-Weighting dB
(1)	(2)	(3)	(4)	(5)
i)	10	-70.4	500	-3.2
ii)	12.5	-63.4	630	-1.9
iii)	16	-56.7	800	-0.8
iv)	20	-50.5	1 000	0
v)	25	-44.7	1 250	0.6
vi)	31.5	-39.4	1 600	1.0
vii)	40	-34.6	2 000	1.2
viii)	50	-30.2	2 500	1.3
ix)	63	-26.2	3 150	1.2
x)	80	-22.5	4 000	1.0
xi)	100	-19.1	5 000	0.6
xii)	125	-16.1	6 300	-0.1
xiii)	160	-13.4	8 000	-1.1
xiv)	200	-10.9	10 000	-2.5
xv)	250	-8.6	12 500	-4.3
xvi)	315	-6.6	16 000	-6.6
xvii)	400	-4.8	20 000	-9.3

A-6 REVERBERATION TIME CALCULATION

An estimate of the reverberation time (T) of a room can be obtained from the Sabine formula:

$$T = \frac{0.16V}{\sum A_i}$$

where

- V = volume of the room in cubic metres (m^3); and
 A_i = equivalent sound absorbing area in the room, in square metres (m^2).

The A_i are the absorbing areas of each surface, or other permanent fixture in the room. Each A_i is determined by multiplying the area of that surface in square metre (m^2) by its absorption coefficient α_{si} . The surface of each significant fixture or feature of the room should be considered as well as the walls, ceiling and floor.

The total absorption is obtained by summing the individual A_i values. As the values of α_{si} are frequency dependent, this calculation should be repeated for each octave band of interest.

An allowance should also be made for people and furnishings in the room.

ANNEX B

(Clauses 2.26, 2.41, 2.44, 2.46, 2.54, 2.55, 2.56 and 2.57)

SPECIFICATION OF SOUND INSULATION**B-1 GENERAL**

Sound insulating elements work mainly by reflecting sound energy back into the source room, not by absorbing it. The methods of measurement and the terms used are described in **B-2** to **B-4**.

B-2 INSULATION AGAINST AIRBORNE SOUND

As per the standard tests, the insulation between a pair of rooms is measured either in third octave bands having centre frequencies which cover at least the range 100 Hz to 3 150 Hz, or in octave bands which cover at least the range 125 Hz to 2 000 Hz. The noise is produced by a loudspeaker in one of the rooms (called the source room) and at each frequency the average noise levels are measured in the source room (L_S) and in the adjacent receiving room (L_R). The difference between these two levels (D) is a measure of the sound insulation between the rooms regardless of the transmission path(s) the sound energy followed to travel between the rooms. The equation is as follows:

$$D = L_S - L_R$$

The actual level in the receiving room depends on the following:

- a) Sound insulation of the separating wall or floor;
- b) Area of the separating wall or floor;
- c) Volume of the receiving room;
- d) Amount of flanking transmission (that is the importance of transmission paths other than the separating wall or floor); and
- e) Amount of absorbing material (for example furniture) in the receiving room.

For field measurements, apart from the amount of absorption, these factors are a property of the building and should be taken into account by the measurement procedure. As the amount of absorbing material (for example soft furniture) in the room at the time of measurement is arbitrary, it should be allowed for separately. This is achieved by measuring the reverberation time (T) of the room in seconds (in s), which is a measure of how long it takes a sound to die away after the source has been switched off. As the sound energy is dissipated as heat in the absorbing material (T), it is related to the total amount of absorption in the room. The receiving room level may then be corrected to the level it would be if the room had a standard reverberation time (T_0) which is typical of furnished rooms, and is taken to be 0.5 s. The corrected level difference is known as the standardized level difference, which has the symbol D_{nT} and is calculated using the following equation:

$$D_{nT} = L_S - L_R + 10 \log_{10}(T/T_0)$$

For laboratory measurements, the insulation of the separating wall or floor being tested is required in a way which is independent of the actual measuring laboratory. For this reason, laboratories are designed to have minimal flanking transmission and a different correction is applied to account for the other factors. This correction is $10 \log_{10}(S/A)$.

where

- S = common area of the separating wall or floor, in square metres (m^2);
- and
- A = equivalent absorption area in the receiving room, in square metres (m^2).

The laboratory corrected level difference at each frequency is known as the sound reduction index, which has the symbol R and is calculated using the following equation:

$$R = L_S - L_R + 10 \log_{10}(S/A)$$

If the test wall or floor is mounted in a realistic way in the laboratory and flanking transmission will be low in the field, the sound reduction index may be used to predict its performance in the field. The relation between D_{nT} and R is given by the following equation:

$$D_{nT} = R - 10 \log_{10}(3S/V)$$

where

- S = area of the separating wall or floor in the field, in square metres (m^2); and
- V = volume of the receiving room in the field, in cubic metres (m^3).

This equation shows that if the source and receiving rooms have different volumes, D_{nT} will depend on which is used as the source room; using the larger room as the source room will give lower value.

B-3 INSULATION AGAINST IMPACT SOUND

The procedure to measure the impact insulation of floors is rather different. Instead of a loudspeaker, a machine containing five small hammers is placed on the floor. While the hammers strike the floor at a rate of 10 blows a second, the resulting noise level (L_i) is measured in the receiving room below at each of the same frequency bands used for airborne insulation. In the field, the receiving room levels are again 'corrected' to a standard reverberation time (T_0) of 0.5 s to give the standardized impact sound pressure level, L_{nT} , which is calculated as follows:

$$L_{nT} = L_i - 10 \log_{10}(T/T_0)$$

In the laboratory, the noise level depends mainly on the characteristics of the floor being tested and the amount of absorption (A m^2) in the laboratory. It is therefore

appropriate to correct the noise level to a standard area of absorption. The area used is 10 m^2 . The resulting normalized impact sound pressure level is given the symbol L_n and calculated as follows:

$$L_n = L_i + 10 \log_{10}(A/10)$$

B-4 RATING SOUND INSULATION

Measurements of insulation against both airborne and impact sounds yield values in a number of frequency bands. To make this information more manageable, rating methods such as those in accordance with [8-4(1)] are used to reduce the frequency band values to single figure ratings. These single figure ratings should be good predictors of subjective assessments of insulation. However, this is not always the case and it is prudent to examine the full measurement data in critical situations. The impact insulation measured on a floor with a carpet is likely to be overestimated by this method.

The more common indices used to describe sound insulation are summarized in Table 11.

Table 11 Common Indices Used to Describe Airborne and Impact Sound Insulation
(Clause B-4)

SI No.	Airborne (A) Impact (I)	Lab (L) Field (F)	Measured Values		Single Number Quantity	
			Name (4)	Symbol (5)	Name (6)	Symbol (7)
i)	A	F	Standardized level difference	D_{nT}	Weighted standardized level difference	$D_{nT,w}$
ii)	A	L	Sound reduction index	R	Weighted sound reduction index	R_w
iii)	I	F	Standardized impact sound pressure level	L'_{nT}	Weighted standardized impact sound pressure level	$L'_{nT,w}$
iv)	I	L	Normalized impact sound pressure level	L'_n	Weighted normalized impact sound pressure level	$L'_{n,w}$

ANNEX C
(Clause 2.24)

NOISE RATING

C-1 Noise rating (NR) is a graphical method for assigning a single number rating to a noise spectrum. It can be used to specify the maximum acceptable level in each octave band of a frequency spectrum, or to assess the acceptability of a noise spectrum for a particular application. The method was originally proposed for use in assessing environmental noise, but was later also found suitable for describing noise from mechanical ventilation systems in buildings. To make a rating, the noise spectrum is superposed on a family of NR contours; the NR of the spectrum corresponds to the value of the first NR contour that is entirely above the spectrum. The data for drawing NR contours (from NR 0 to NR 75) is given in Table 12 for the frequency range 31.5 Hz to 8 kHz.

Table 12 Noise Rating Values
(Clause C-1)

SI No.	Noise Rating	Octave Band Centre Frequency, Hz For Sound Pressure Levels dB _{re} 20 µPa								
		31.5	63	125	250	500	1 000	2 000	4 000	8 000
(1)	(2)	(3)	(4)	(5)	(6)	(7)	(8)	(9)	(10)	(11)
i)	NR75	106	95	87	82	78	75	73	71	69
ii)	NR70	103	91	83	77	73	70	68	66	64
iii)	NR65	100	87	79	72	68	65	62	61	59
iv)	NR60	96	83	74	68	63	60	57	55	54
v)	NR55	93	79	70	63	58	55	52	50	49
vi)	NR50	89	75	66	59	53	50	47	45	43
vii)	NR45	86	71	61	54	48	45	42	40	38
viii)	NR40	83	67	57	49	44	40	37	35	33
ix)	NR35	79	63	52	45	39	35	32	30	28
x)	NR30	76	59	48	40	34	30	27	25	23
xi)	NR25	72	55	44	35	29	25	22	20	18
xii)	NR20	69	51	39	31	24	20	17	14	13
xiii)	NR15	66	47	35	26	19	15	12	9	7
xiv)	NR10	62	43	31	21	15	10	7	4	2
xv)	NR5	59	39	26	17	10	5	2	-1	-3
xvi)	NR0	55	35	22	12	5	0	-4	-6	-8

C-2 For computational methods, the curves are defined by the equation:

$$L = a + bN$$

where

L = octave band sound pressure level corresponding to NR level N; and

a and b = constants for each frequency band, as given in Table 13.

NOTE – NR values cannot be converted directly to dBA values but the following approximate relationship applies:

$$NR = dBA - 6$$

C-3 Although the NR system is currently the preferred method for rating noise from mechanical ventilation system, other methods which are more sensitive to noise at low frequencies are available, but they are not yet widely accepted. Low frequency noise may be disturbing or fatiguing to occupants, but may not have much effect on the dBA or NR value.

Table 13 Values of a and b
(Clause C-2)

SI No.	Octave Band Centre Frequency Hz	a	b
(1)	(2)	(3)	(4)
i)	31.5	55.4	0.681
ii)	63	35.4	0.790
iii)	125	22.0	0.870
iv)	250	12.0	0.930
v)	500	4.2	0.980
vi)	1 000	0.0	1.000
vii)	2 000	- 3.5	1.015
viii)	4 000	- 6.1	1.025
ix)	8 000	- 8.0	1.030

ANNEX D
(Clause 3.3)

OUTDOOR NOISE REGULATIONS IN INDIA

D-1 Government notifications are issued from time to time on the allowable ambient noise levels in general and specifically in different zones of various metropolitan cities of India.

D-2 Noise regulations and notifications are also issued from time to time specifying the maximum permissible sound levels from equipment commonly used in and around the residential areas and around sensitive buildings, specifically with regard to noise levels from electricity generating sets, construction equipment and HVAC utility equipment installed outdoors.

D-3 These regulations should be referred to by the designer for the design of measures for control of external noise.

ANNEX E

(Clauses 3.8 and 4.5)

SPECIAL PROBLEMS REQUIRING EXPERT ADVICE

E-1 GENERAL

Certain design problems require reliable advice of a kind which is not easy to find in published material. The advice of an expert should be sought for these kinds of problems, some examples of which are given in **E-2** to **E-9**.

E-2 ACOUSTIC TEST ROOMS

The design of rooms in which acoustic measurements are carried out, such as reverberation chambers, free-field anechoic rooms and audiometric test rooms, usually requires the advice of an expert.

E-3 PERFORMING SPACES

The design of theatres, opera houses, concert halls and similar performing spaces usually requires expertise in room acoustics and noise control. The intrusion of quite low levels of noise may seriously interfere with the enjoyment of the performance and distract the performers. The requirements for low noise levels often mean that more room has to be allocated for low velocity ventilation ductwork and the impact on the design of the ventilation system is often substantial.

E-4 BROADCASTING AND RECORDING STUDIOS

Broadcasting and recording studios have requirements similar to those of performing spaces. For some infrequent intrusive noises, the requirements are sometimes relaxed on the grounds that a retake of a recording can be done, but this can result in higher operating costs.

E-5 AIRCRAFT NOISE

As there are many variables affecting the level of aircraft noise heard on the ground, expert advice is almost always required. Contours of daytime $L_{Aeq,T}$ levels are available from most major airports. Where measurements of façade insulation are necessary a standard test method may be referred.

E-6 GROUND-BORNE NOISE

Projects involving ground-borne noise from underground trains usually require expert advice.

E-7 LOW-FREQUENCY NOISE

Projects involving low-frequency noise usually require expert advice as accurate measurement is difficult and there is a shortage of reliable data below 100 Hz.

E-8 ACTIVE NOISE CONTROL

Active noise control is the reduction of noise by cancellation with a similar noise (anti-noise) generated by electro-acoustic means. The technique is still under development, but commercial systems are available which successfully reduce low frequency noise from mechanical ventilation systems.

E-9 NOISE SURVEYS

Noise surveys are carried out for a variety of reasons, for example,

- a) Before construction, to establish the existing noise climate at the site of a proposed development where reliable prediction is impracticable, as an aid to the design of the building envelope, either to protect against external noise or contain internally produced noise;
- b) During construction, to monitor noise from building activity, either to assess the likely nuisance to the local community or the risk of hearing damage to the work force;
- c) At the end of a building contract to check the insulation of the building envelope, or the noise levels produced by the services;
- d) As part of a planning requirement;
- e) To provide objective evidence to support or defend a legal action.

The expense of carrying out a comprehensive noise survey of any kind is likely to be high, so the cost-effectiveness of a full or partial survey should be weighed against alternatives such as prediction. A survey will generally be more accurate and can take account of factors such as prevailing wind conditions.

ANNEX F

(Clause 4.4)

AIRBORNE AND IMPACT SOUND INSULATION

F-1 GENERAL

Airborne sound refers to sources which produce sound by directly setting the air around them into vibration. Impact sound refers to sources which produce sound by impulsive mechanical excitation of part of a building (for example by footsteps, electric light switches, slamming doors). Many sources of impact sound also produce significant levels of airborne sound. The term structure-borne sound has no very precise meaning as the structure can be excited by both airborne and impact sources; it is often used to refer to sound that travels for long distances *via* the structure, especially in connection with vibrating machinery linked directly to the structure.

F-2 DIRECT AND INDIRECT TRANSMISSION

Figure 6 shows diagrammatically a pair of rooms in a house where the construction consists of solid walls, etc, bonded together. Sound travelling from room 1 to room 2 may travel *via* the direct path a-a and by the many indirect, or flanking, paths shown. The term flanking transmission is usually used to mean transmission paths involving the structure, while the term indirect transmission includes flanking paths and airborne paths through gaps and ducts, etc. The indirect paths may limit the sound insulation attainable no matter how much the direct sound is reduced by the separating wall or floor. The indirect transmission can be reduced by measures such as the following:

- a) Increasing the mass of the flanking walls;
- b) Increasing the mass of the partition and bonding it to the flanking walls;
- c) Introducing discontinuities in the indirect paths;
- d) Erecting independent wall linings adjacent to the flanking walls to prevent energy entering the flanking construction; and
- e) Sealing any air gaps and paths through ducts.

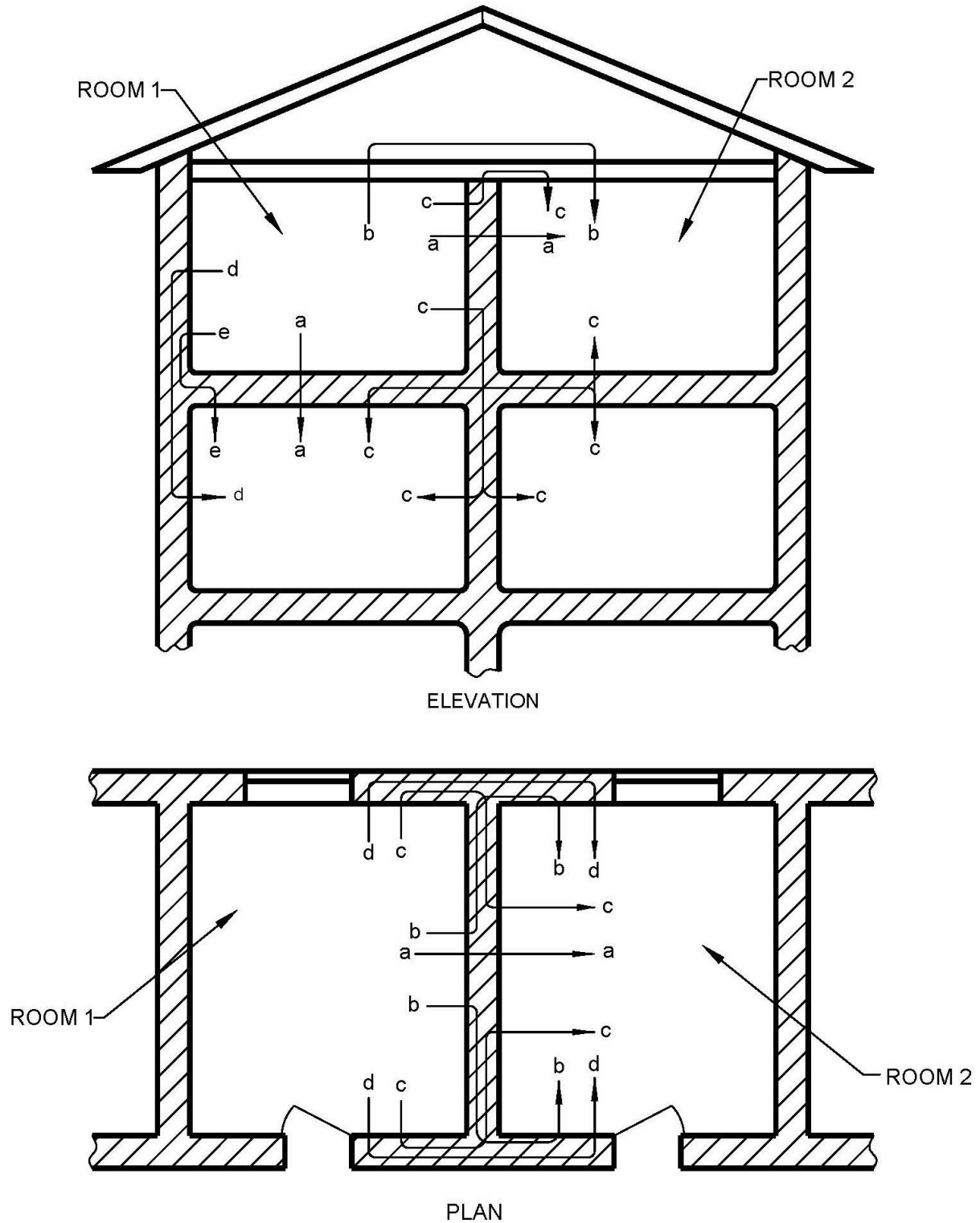
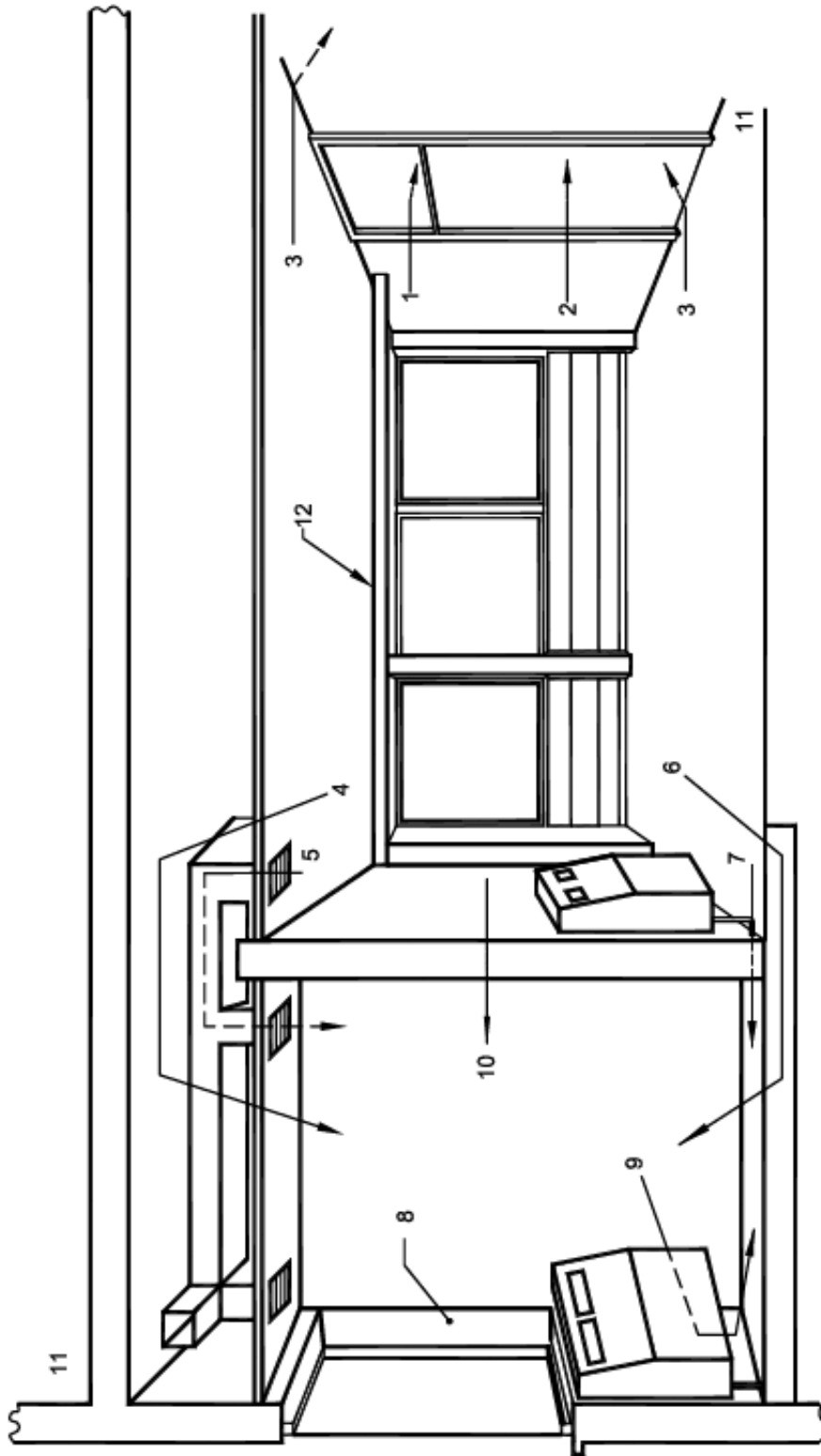

FIG. 6 TRANSMISSION PATHS (VIA THE STRUCTURE) OF NOISE ORIGINATING IN ROOM 1 (DIAGRAMMATIC)

Figure 7 shows a number of indirect paths that have been found in offices.

It is important to remember that standard test laboratories are designed to minimise transmission by all paths other than the direct path. This makes it difficult to relate the results of laboratory measurements to those likely to be obtained in the field.



- | | |
|--|--|
| 1 LIGHT WEIGHT PANELS ABOVE DOORS | 7 ELECTRICAL OUTLETS AND SERVICE PIPES |
| 2 DOORS | 8 LIGHT WEIGHT MULLIONS OR MULLION/PARTITION CLOSERS |
| 3 AIR LEAKS THROUGH GAPS, CRACKS OR HOLES | 9 CONTINUOUS SILL LINE HEATING |
| 4 SOUND TRANSMISSION VIA SUSPENDED CEILINGS/PARTITIONS | 10 PARTITION PERFORMANCE |
| 5 COMMON VENTILATION SYSTEMS WITHOUT SILENCERS | 11 APPLIANCES |
| 6 COMMON FLOOR DUCT | 12 CONTINUOUS LIGHTING FITTINGS |

FIG. 7 INDIRECT SOUND LEAKAGE PATHS

F-3 AIRBORNE SOUND INSULATION

F-3.1 General

The sound insulation of structural elements such as walls and floors always varies with frequency, the insulation rising in general as the frequency rises.

F-3.2 Terminology

Results from field measurements are usually expressed in terms of the weighted standardized level difference, while laboratory measurements are usually expressed in terms of the sound reduction index. In the absence of significant flanking transmission, the numerical difference between the weighted standardized level difference and the sound reduction index of a wall or floor is usually small for furnished rooms in dwellings, and so either quantity may be used in considering principles; for this purpose it is, therefore, convenient to use the general term insulation.

F-3.3 Mass Law

An approximate empirical relationship has been established between sound insulation and mass for single leaf constructions as shown in Fig. 8. This so called 'Mass Law' gives a useful first approximation to the behaviour of a single sheet or plate. In practice, the sound insulation predicted by the mass law may not be attained because of factors such as the coincidence effect, which is outlined in **F-3.4**. Results for specific materials vary around the value given by the Mass Law relationship, and so measured data should be used when available. Table 14 gives a lists of materials and indicates the sound insulation of a single, imperforate sheet when fixed to a suitable wood or metal framework. These values are useful, for example when assessing existing structures.

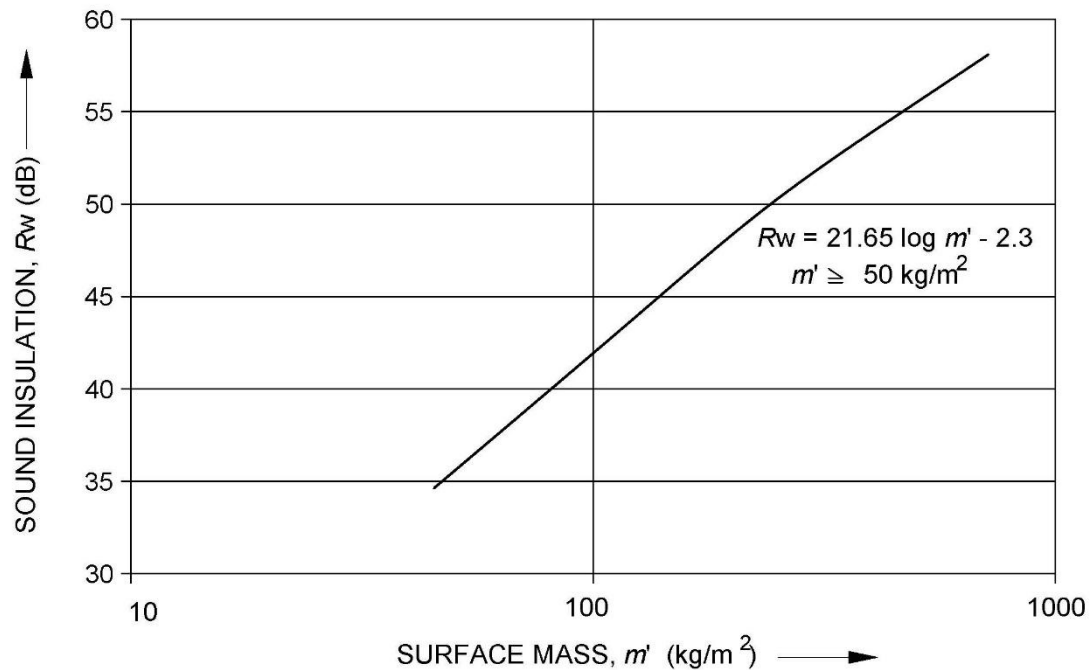

FIG. 8 MASS LAW CURVE

Table 14 Sound Insulation of Imperforate Sheet Materials
(Clause F-3.3)

SI No.	Material	Surface Mass	Typical Weighted Sound Reduction Index
		kg/m^2	R_w dB
(1)	(2)	(3)	(4)
i)	3 mm glass sheet	7.0	26
ii)	12.5 mm plasterboard	10.5	31
iii)	18 mm wood particle board	8.0	27
iv)	19 mm plywood	3.0	24
v)	16 mm plywood	4.5	24
vi)	1 mm steel sheet	11.0	29
vii)	6 mm hardboard	5.0	25
viii)	12 mm wood fibre insulation board	4.0	24
ix)	13 mm mineral fibre board	4.0	24
x)	50 mm wood-wool screeded one side	35.0	33

F-3.4 Coincidence Effect

The coincidence effect occurs when the wavelength of the wave impressed on the panel by the incident sound wave is close to the wavelength of free bending waves in the panel. The effect of coincidence is to lower the sound insulation of a construction by as much as 10 dB below the level expected from its mass per unit area over a limited frequency range. The coincidence effect can be pronounced with thin light weight partitions, resulting in loss of insulation at middle and high frequencies. Reducing the stiffness without a corresponding reduction of mass can raise the critical frequency above 3 150 Hz, and so improve the insulation over the important 100 Hz to 3 150 Hz range. An increase of stiffness will have the reverse effect.

It is possible to design lightweight stud partitions so that they perform to their maximum effect in the speech frequency region between 250 Hz and 2 000 Hz, that is between the mass-spring-mass and coincidence regions respectively.

The worst coincidence dips occur in materials such as plate glass and rigid metal sheets. Heavily damped materials such as lead sheets are least affected.

F-3.5 Mass-Spring-Mass Frequency

A double leaf wall can perform better than a single leaf wall of similar mass because the sound has to pass through two barriers. If the two leaves are not connected to each other, the insulation values of the two leaves may be added together. However, in practice the leaves are often connected by ties or studs, and the full insulation cannot be achieved. Even where the two leaves are isolated from each other, the full benefit can only be obtained above a certain frequency that depends on the cavity width. This is because the air in the cavity behaves like a spring connecting the leaves together, and causes a resonance at the mass-spring-mass frequency. Below this frequency, the two leaves behave more like an equivalent single leaf.

Making the cavity width wide can reduce the mass-spring-mass frequency, as in the case of sound insulating secondary glazing. The mass-spring-mass frequency (F_0) may be estimated from the following equation:

$$F_0 = 59.6 \sqrt{\frac{1}{d} \left(\frac{1}{m_1} + \frac{1}{m_2} \right)}$$

where

m_1 and m_2 = surface masses of the two leaves, in kilograms per square metre (kg/m^2); and

d = cavity width, in metres (m).

F-3.6 Impact Sound Control

A structure that receives an impact or has a vibrating source in contact with it behaves more like an extension of the source rather than an intervening element between

source and listener. For this reason, a relatively small amount of impact energy may produce a loud sound and, if the structure is continuous, the sound may travel a long distance. Control is usually obtained by inserting a resilient surface at the point of contact with the source (for example laying a carpet on a floor) or by introducing a structural discontinuity.

Floating floors, which are an example of the latter approach, are a common method of controlling impact sound from footsteps. However, it should be noted that an effective floating floor may result in increased sound from impacts on the source side of the floor.

F-4 AIRBORNE INSULATION VALUES OF WALLS AND AIRBORNE AND IMPACT INSULATION VALUES OF FLOORS

Table 15 and Table 16 give examples of common types of wall and floor construction with sound insulation in the ranges shown. The insulation indices are for field measurements accessed in accordance with good practice [8-4(4)]. The insulation values given are necessarily approximate since examples of nominally identical constructions may show variations of several decibels. All the figures represent values expected in the field, that is, in actual buildings. Many are based directly on field measurements, though other (in the absence of representative field measurements) have been assessed from laboratory data, with an allowance for typical flanking conditions in normal buildings. Variation in the amount of indirect transmission may affect significantly the insulation between two rooms separated by a given barrier. For example, the sound insulation of some types of floor may be reduced by indirect transmission along the walls supporting them, particularly if these walls are of lightweight masonry and carried past the floor.

Table 15 Airborne Sound Insulation of Walls and Partitions
(Clause F-4)

SI No.	Sound Insulation $D_{nT,w}$ dB	Type of Wall or Partition
(1)	(2)	(3)
i)	26 to 33	a) 1 mm steel sheet panels fixed to steel frame members to form demountable partition units 50 mm overall thickness. Mineral wool cavity insulation b) Plywood or wood fibre board 12 mm thick nailed both sides of 50 mm x 50 mm timber framing members spaced at 400 mm centres c) Paper faced strawboard or wood wool 50 mm thick panels plastered both sides d) Chipboard hollow panels 50 mm thick tongued and grooved edges, hardboard faced. Joints covered with wood trim

SI No.	Sound Insulation $D_{nT,w}$ dB	Type of Wall or Partition
(1)	(2)	(3)
ii)	33 to 37	<ul style="list-style-type: none"> a) Lightweight masonry blockwork. Plaster or drylining on at least one side. Overall mass per unit area not less than 50 kg/m² b) Laminated plasterboard at least 50 mm thick fixed to timber perimeter framing, any suitable finish. Approximate mass per unit area 35 kg/m² c) Timber stud partitions any size timbers greater than 50 mm x 50 mm, 400 mm centres, cross noggins, 9.5 mm plasterboard lining on both sides, any suitable finish d) Metal stud partition, 50 mm studs 600 mm centres, clad both sides with 12.5 mm plasterboard, joints filled and perimeters sealed. Approximate mass per unit area 18 kg/m² e) 50 mm lightweight masonry blockwork, plastered both sides to 12 mm thickness or drylined with 9.5 mm plasterboard
iii)	37 to 43	<ul style="list-style-type: none"> a) Lightweight masonry blockwork, plaster or dry lining on at least one side. Overall mass per unit area not less than 75 kg/m² b) Metal stud partition, 50 mm studs 600 mm centres, clad both sides with 12.5 mm plasterboard, joints filled and perimeters sealed. 25 mm mineral fibre quilt hung between studs. Approximate mass per unit area 18 kg/m²
iv)	43 to 50	<ul style="list-style-type: none"> a) Masonry wall, joints well filled. Either plaster or dry lining on both sides. Overall mass per unit area not less than 150 kg/m² b) 100 mm metal stud partition, 'C' section studs not greater than 600 mm spacing, not less than nominal 50 mm web depth. Clad on both sides with two layers of plasterboard of not less than 25 mm combined thickness. Mineral fibre quilt hung between studs. Approximate mass per unit area 35 kg/m² c) 75 mm x 50 mm timbers framing using staged studs at 300 mm spacing with 25 mm stagger

SI No.	Sound Insulation $D_{nT,w}$ dB	Type of Wall or Partition
(1)	(2)	(3)
		<p>forward and back. Frame clad with two layers of 12.5 mm of plasterboard on both sides. Mineral fibre quilt hung between studs. Approximate mass per unit area 36 kg/m²</p> <p>d) 50 mm x 25 mm timber stud partition to form a 25 mm cavity, clad on both sides with minimum 38 mm wood wool slabs having their outer faces screeded or plastered</p> <p>e) Solid autoclaved aerated concrete block 215 mm thick plaster or dry lined finish on both sides, blockwork joints well filled. Overall mass per unit area not less than 160 kg/m²</p>
v)	50 to 54	<p>a) Two separate frames of timber studs not less than 89 mm x 38 mm, or boxed metal studwork with 50 mm minimum web depth Studs at 600 mm maximum centres. A 25 mm mineral wool quilt suspended between frames. Frames spaced to give a minimum 200 mm overall cavity. Clad on outside of each frame with a minimum of 30 mm plasterboard layers (for example 19 mm plus 12.5 thickness). Approximate mass per unit area 54 kg/m² ¹⁾</p> <p>b) Either in situ or pre-cast concrete wall panel not less than 175 mm thick and not less than 415 kg/m². All joints well filled ¹⁾</p> <p>c) Brick wall nominal 230 mm thickness, weight (including plaster) not less than 380 kg/m². Plaster or dry-lined finish both sides. Brick work joints well filled ¹⁾</p> <p>d) 'No fines' concrete 225 mm thickness, weight (including plaster) not less than 415 kg/m². Plaster or dry-lined finish both sides ¹⁾</p> <p>e) Cavity lightweight aggregate block (maximum density of block 1 600 kg/m³) with 75 mm cavity and wall ties of the butterfly wire type. Dry lined finish on both sides. Joints in blockwork well filled. Overall mass per unit area not less than 300 kg/m² ¹⁾</p> <p>f) Dense aggregate concrete block cavity wall with 50 mm cavity and wall ties of the butterfly wire type. Dry lined finish on both sides.</p>

SI No.	Sound Insulation $D_{nT,w}$ dB	Type of Wall or Partition
(1)	(2)	<p data-bbox="702 432 1348 499">Joints in block work well filled. Overall mass per unit area not less than 415 kg/m² ¹⁾</p> <p data-bbox="654 504 1348 757">g) Autoclaved aerated concrete block cavity wall consisting of two leaves, 100 mm blocks not less than 75 mm apart, with wall ties of the butterfly type. Plaster or dry line finish on both sides. Joints in blockwork well filled. Overall mass per unit area not less than 150 kg/m² ¹⁾</p>

SI No.	Sound Insulation $D_{nT,w}$ dB	Type of Wall or Partition
(1)	(2)	(3)
vi)	54 to 60	<p>a) Two separate frames of timber studs not less than 100 mm x 50 mm spaced at 600 mm maximum centres. A 50 mm mineral wool quilt in each frame between studs. Frames spaced to give a minimum 300 mm overall cavity. Each frame clad on outside with three layers of 12.5 mm plasterboard nailed to framing. Approximate mass per unit area 51 kg/m² ¹⁾</p> <p>b) Two separate frames of boxed 'C' section galvanized nominal 150 mm steel studs 100 mm apart with a 400 mm overall cavity. 50 mm mineral wool quilt fixed to the back of one frame each frame clad on outside with three layers of 12.5 mm plasterboard by self drilling or tapping screws. Approximate mass per unit area 47 kg/m² ¹⁾</p> <p>c) Solid masonry with an overall mass per unit area of not less than 700 kg/m² fully sealed both sides ¹⁾</p> <p>d) Dense aggregate concrete block solid wall 215 mm thick plaster finish to both surfaces. Overall mass per unit area not less than 415 kg/m² ¹⁾</p> <p>e) Cavity lightweight aggregate block (maximum density of block 1 600 kg/m³) with 75 mm cavity and wall ties of the butterfly wire type. Plaster finish on both sides. Joints in blockwork well filled. Overall mass per unit area not less than 300 kg/m² ¹⁾</p> <p>f) Dense aggregate concrete block cavity wall with 50 mm cavity and wall ties of the butterfly wire type. Plaster finish on both sides. Joints in blockwork well filled. Overall mass per unit area not less than 415 kg/m² ¹⁾</p>

SI No.	Sound Insulation $D_{nT,w}$ dB	Type of Wall or Partition
(1)	(2)	(3)

NOTES

- 1 Construction details and workmanship are important if the levels of sound insulation indicated are to be achieved.
- 2 Where plasterboard is specified it is assumed that the surface mass will be at least 6.5 kg/m² for 9.5 mm thick board, at least 8.5 kg/m² for 12.5 mm thick board, and at least 14.5 kg/m² for 19 mm thick board. If less dense plasterboard is used, the thickness should be increased.

¹⁾ When considering these constructions for separating walls, expert advice should be sought.

Table 16 Airborne and Impact Sound Insulation of Floor Constructions
(Clause F-4)

SI No.	Sound Insulation dB	Type of Floor Construction
(1)	(2)	(3)
i)	$D_{nT,w} = 49$ to 54 $L'_{nT,w} = 56$ to 65	<p>a) A concrete floor having mass per unit area not less than 365 kg/m², including any screed or ceiling finish directly bonded to the floor slab; together with a floating floor or resilient floor covering equivalent to rubber or sponge rubber underlay or thick cork tile (for example carpet and underlay or sponge rubber backed vinyl flooring)</p> <p>b) A solid floor consisting of:</p> <ol style="list-style-type: none"> 1) a solid slab; or 2) concrete beams and infilling blocks; or 3) hollow concrete planks; together with a floating floor. A ceiling finish is required for a beam and block floor. In each case the slab should have a mass per unit area of at least 300 kg/m², including any screed or ceiling finish directly bonded to it.

Where a floating floor is laid over a floor of beams and hollow infill blocks or hollow beams

SI No.	Sound Insulation dB	Type of Floor Construction
(1)	(2)	(3)
		<p>along the top of the structural floor, it should be sealed and levelled before the resilient layer is put down. It is also essential to have due regard for conduits and pipework which should be laid and covered so as to prevent any short circuit of the floor's isolating properties.</p> <p>If precast units are used as a structural floor, it is essential that the joints are filled to ensure that the sound insulation performance is maintained.</p> <p>The resilient material is laid to cover completely the structural floor and turned up against the surrounding wall along all edges. The resilient layer is usually of mineral fibre, or a special grade of expanded polystyrene. When the screed is laid, it is important that none of the mix finds its way through the resilient layer to the structural floor, as this will short circuit the isolation between the two decks and significantly reduce the sound insulation</p>
		<p>c) A floor consisting of boarding nailed to battens laid to float upon an isolating layer of mineral fibre capable of retaining its resilience under imposed loading. With battens running along the joists, a dense fibre layer can be used in strips. The ceiling below to be of metal lath and plaster not less than 29 mm thick, with pugging on the ceiling such that the combined mass per unit area of the floor, ceiling and pugging is not less than 120 kg/m². This construction will only give values for $D_{nT,w}$ of 50 to 53 dB, and a value for $L'_{nT,w}$ of 75 dB</p> <p>d) A floor consisting of 18 mm tongued and grooved chipboard on 19 mm plasterboard laid on battens running parallel to the joists and supported on 25 mm thick mineral wool of about 90 kg/m³ to 140 kg/m³ density; 100 mm of fibre absorbent (as used for insulation in roof spaces) laid between the joists on top of the plasterboard ceiling ¹⁾</p>

SI No.	Sound Insulation dB	Type of Floor Construction
(1)	(2)	(3)
		e) A floor consisting of 18 mm tongued and grooved chipboard on 19 mm plasterboard floating on a 25 mm thick mineral wool layer of about 60 kg/m ³ to 80 kg/m ³ density; this on a 12.5 mm plywood platform; 100 mm of fibre absorbent laid between the joists on top of the plasterboard ceiling ¹⁾
ii)	$D_{nT,w} = 32$ to 36 $L'_{nT,w} = 80$ to 85	Timber joist floor consisting of 22 mm tongued and grooved floor boarding or equivalent fixed directly to floor joists. Ceiling of 12.5 mm plasterboard and skim with no floor covering

NOTES

- 1 Construction details and workmanship are important if the levels of sound insulation indicated are to be achieved.
 - 2 Where plasterboard is specified it is assumed that the surface mass will be at least 8.5 kg/m³ for 12.5 mm thick board, and at least 14.5 kg/m² for 19 mm thick board. If less dense plasterboard is used, the thickness should be increased.
- ¹⁾ In these types of floor construction, the ceiling may be 19 mm plus 12.5 mm plasterboard.

It is imperative that the resilient layer is not punctured by nails.

In many cases, simple solid partitions give insulation values according to their mass (see **F-3.3**). Moreover, with partitions of this type there is usually little variation between field and laboratory test results unless the laboratory insulation exceeds 45 dB. Exceptions may occur in buildings that have not been specially designed to minimise common cavities and strongly coupled elements in lightweight panelling. The examples given are not exhaustive. Flanking structures are not listed since these can vary widely and are often dependent upon other factors such as thermal insulation, which are outside the scope of this Code.

ANNEX G
(Clause 13.1)**BASIC DESIGN TECHNIQUES FOR NOISE CONTROL IN AIR CONDITIONING,
HEATING AND MECHANICAL VENTILATION SYSTEM**

G-1 When selecting fans and other related mechanical equipment and when designing air distribution systems to minimise the sound transmitted from different components to the occupied spaces that they serve, the following recommendations should be considered:

- a) Design the air distribution system to minimise flow resistance and turbulence. High flow resistance increases the required fan pressure, which results in higher noise being generated by the fan. Turbulence increases the flow noise generated by duct fittings and dampers in the air distribution system, especially at low frequencies.
- b) Select a fan to operate as near as possible to its rated peak efficiency when handling the required quantity of air and static pressure. Also, select a fan that generates the lowest possible noise but still meets the required design conditions for which it is selected. Using an oversized or undersized fan that does not operate at or near rated peak efficiency may result in substantially higher noise levels.
- c) Design duct connections at both the fan inlet and outlet for uniform and straight air flow. Failure to do this may result in severe turbulence at the fan inlet and outlet and in flow separation at the fan blades. Both of these may significantly increase the noise generated by the fan.
- d) Select duct silencers that do not significantly increase the required fan total static pressure.
- e) Place fan-powered mixing boxes associated with variable volume air distribution systems away from noise-sensitive areas.
- f) Minimise flow-generated noise by elbows or duct branch take-offs, whenever possible, by locating them at least four to five duct diameters from each other. For high velocity systems, it may be necessary to increase this distance to up to ten duct diameters in critical noise areas.
- g) Keep airflow velocity in the duct as low as possible (7.5 m/s or less) near critical noise areas by expanding the duct cross-section area. However, do not exceed an included expansion angle of greater than 15°. Flow separation, resulting from expansion angles greater than 15°, may produce rumble noise. Expanding the duct cross-section area will reduce potential flow noise associated with turbulence in these areas.
- h) Use turning vanes in large 90° rectangular elbows and branch takeoffs. This provides a smoother transmission in which the air can change flow direction, thus reducing turbulence.

- j) Place grilles, diffusers and registers into occupied spaces as far as possible from elbows and branch takeoffs.
- k) Minimise the use of volume dampers near grills, diffusers and registers in acoustically critical situations.
- m) Vibration isolates all vibrating reciprocating and rotating equipment if mechanical equipment is located on upper floors or is roof-mounted. Also, it is usually necessary to vibration isolate the mechanical equipment that is located in the basement of a building as well as piping supported from the ceiling slab of a basement, directly below tenant space. It may be necessary to use flexible piping connectors and flexible electrical conduit between rotating or reciprocating equipment and pipes and ducts that are connected to the equipment.
- n) Vibration isolates ducts and pipes, using spring and/or neoprene hangers for at least the first 15m from the vibration-isolated equipment.
- p) Use barriers near outdoor equipment when noise associated with the equipment will disturb adjacent properties if barriers are not used. In normal practice, barriers typically produce no more than 15 dB of sound attenuation in the mid-frequency range.
- q) Table 17 lists several common sound sources associated with mechanical equipment noise. Anticipated sound transmission paths and recommended noise reduction methods are also listed in the Table 18. Airborne and/or structure-borne sound can follow any or all of the transmission paths associated with a specified sound source.

**Table 17 Sound Sources, Transmission Paths and
Recommended Noise Reduction Methods**
[Clause G-1(q)]

SI No. (1)	Sound Source (2)	Path No. (see Table 18) (3)
i)	Circulating fans, grilles, registers, diffusers, unitary equipment in room	1
ii)	Induction coil and fan-powered VAV mixing units	1, 2
iii)	Unitary equipment located outside of room served; remotely located air-handling equipment, such as fans, blowers, dampers, duct fitting, and air washers	2, 3

iv)	Compressors, pumps, and other reciprocating and rotating equipment (excluding air-handling equipment)	4, 5, 6
v)	Cooling towers; air-cooled condensers	4, 5, 6, 7
vi)	Exhaust fans; window air conditioners	7, 8
vii)	Sound transmission between rooms	9, 10

Table 18 Sound Transmission Paths and Recommended Noise Reduction Methods
[Clause G-1(q) and Table 17]

SI No. (1)	Path No. (2)	Transmission Paths (3)	Noise Reduction Methods (4)
i)	1	Direct sound radiated from sound sources to ear	Direct sound can be controlled only by selecting quiet equipment
		Reflected sound from walls, ceiling and floor	Reflected sound is controlled by adding sound absorption to the room and to equipment location
ii)	2	Air and structure-borne sound radiated from casings and through walls of ducts and plenums is transmitted through walls and ceiling into rooms	Design duct and fittings for low turbulence; locate high velocity ducts in noncritical areas; isolate ducts and sound plenums from structure with neoprene or spring hangers
iii)	3	Airborne sound radiated through supply and return air ducts to diffusers in room and then to listener by Path 1	Select fans for minimum sound power; use ducts lined with sound-absorbing material; use duct silencers or sound plenums in supply and return air ducts
iv)	4	Noise transmitted through equipment room walls and floors to adjacent rooms	Locate equipment rooms away from critical areas; use masonry blocks or concrete for equipment room walls and floor

v)	5	Vibration transmitted via building structure to adjacent walls and ceilings, from which it radiates as noise into room by Path 1	Mount all machines on properly designed vibration isolators; design mechanical equipment room for dynamic loads; balance rotating and reciprocating equipment
vi)	6	Vibration transmission along pipes and duct walls	Isolate pipe and ducts from structure with neoprene or spring hangers; install flexible connectors between pipes, ducts, and vibrating machines
vii)	7	Noise radiated to outside enters room windows	Locate equipment away from critical areas; use barriers and covers to interrupt noise paths; select quiet equipment
vii)	8	Inside noise follows Path 1	Select quiet equipment
ix)	9	Noise transmitted to an air diffusers in a room, into a duct, and out through an air diffuser in another room	Design and install duct attenuation to match transmission loss of wall between rooms
x)	10	Sound transmission through, over, and around room partition	Extend partition to ceiling slab and tightly seal all around; seal all pipe, conduit, duct and other partition penetrations

G-2 Room Criteria (RC)

This is the rating methodology specifically intended for rating the heating ventilation and air-conditioning system-related noise in buildings and estimate the subjective response of an occupant. The subjective character or quality of the spectrum is determined by a calculation of the Quality Assessment Index (QAI). The QAI is a measure of the degree to which the shape of the spectrum under evaluation deviates from the shape of the RC reference curve.

NOTE – The RC Mark II rating is a two-dimensional expression, which takes the form, RC xx(yy). The first term, “xx,” is the value of the RC reference curve corresponding to the arithmetic average of the levels in the 500 Hz, 1 000 Hz, and 2 000 Hz octave bands; it is a quantitative descriptor, in the sense that it identifies the level of the spectrum in the principal speech frequency region. The second term, “yy” is a qualitative descriptor that identifies the character of the sound as perceived by the listener: (N) for neutral, (LF: 16 – 63 Hz) for low-frequency dominant (rumble), (MF: 125 – 500 Hz) for mid-frequency dominant (roar), and (HF: 1 000 – 4 000 Hz) for high-frequency dominant (hiss). There are also two sub-categories of

the low-frequency descriptor: (LF_A), denoting a substantial, clearly noticeable degree of sound-induced vibration of room sur-faces in lightweight interior building construction, and (LF_B), denoting a moderate, but perceptible degree of sound-induced vibration.

ANNEX H
(Clause 13.2)

SUGGESTED EQUIPMENT NOISE DATA SHEET

H-1 It is recommended that an equipment noise data sheet be furnished to intending bidders of mechanical equipment such as air conditioning, heating and mechanical ventilation machinery or diesel generating units specifying noise requirements at the time of request for quotation. Following is a sample noise data sheet suggested for the purpose:

SAMPLE OF EQUIPMENT NOISE DATA SHEET FOR NOISE SPECIFICATION TO BE SENT TO SUPPLIERS				
Equipment Description _____		Type _____		Item No. _____
Octave-Band Centre Frequency Hz	Desired Sound Pressure Level, L_p	Supplier to Complete		
		Actual	Special Design	Special Noise Control Measures Recommended
(1)	(2)	(3)	(4)	(5)
63				
125				
250				
500				
1 000				
2 000				
4 000				
8 000				

NOTES

- 1** The measurements of SPL shall be at a distance of 1.0 m from the equipment and 1.5 m above grade or floor. The measurement method shall be described and the point of maximum levels furnished.
- 2** Complete column 3 for actual levels of standard equipment.
- 3** Complete column 4 for special design for low noise (if such alternative is available).
- 4** Complete column 5 for noise control measures such as enclosure.
- 5** Indicate if the equipment meets the specified noise levels without modification (Yes/No).
- 6** If no, additional costs required :
For Column 4 _____
For Column 5 _____

It will be observed from the columns 3, 4 and 5 that the buyer would get quotation for supply of standard equipment at a price P-1, whose noise characteristics would be as per column 3. Column 4 would indicate acoustical performance for a special design at a price P-2. Column 5 would indicate the acoustical performance if the owners were

to provide special noise control measures for the installation (whose broad details and approximate estimated cost is also furnished by the vendor).

ANNEX J
*(Clause 3.5)***INTEGRATION OF NOISE BARRIERS AND NOISE ABATEMENT MEASURES IN ZONAL AND URBAN PLANNING****J-1 APPLICABILITY**

J-1.1 These provisions establish requirements for incorporating noise barriers and noise abatement measures in the preparation of zonal plans to control noise pollution in urban and semi-urban areas.

J-1.2 The provisions shall apply to all zonal plans developed by municipal corporations, urban development authorities, and town planning bodies.

J-2 IDENTIFICATION AND SEGREGATION OF ZONES**J-2.1 Noise-Sensitive Zones (NSZs)**

Zonal plans shall identify noise-sensitive zones that include residential areas, educational institutions, healthcare facilities, and public parks, among others.

J-2.2 Noise-Generating Zones (NGZs)

Zonal plans shall also identify noise-generating zones that include industrial areas, major transportation corridors, commercial zones, and recreational spaces prone to high noise levels.

J-2.3 Buffer Zones

Buffer zones shall be established between NSZs and NGZs to minimize noise impacts. Buffer zones may include green belts, mixed-use developments, or other suitable land uses. The width and nature of buffer zones shall be defined based on local conditions and practical feasibility.

J-3 NOISE BARRIERS**J-3.1 Requirement for Noise Barriers**

Noise barriers shall be required along major transportation corridors, such as highways and railway lines, adjacent to NSZs. The need for noise barriers shall be determined based on the predicted noise levels and potential impact on NSZs.

J-3.2 Design criteria for noise barriers shall be as per Annex K.

J-3.3 Placement of Noise Barriers

Noise barriers should be placed as close as possible to the noise source or the boundary of NSZs to maximize effectiveness.

J-4 NOISE ABATEMENT MEASURES IN ZONAL PLANS

J-4.1 Noise Mapping and Assessment

Zonal plans shall include noise mapping to identify areas with high noise levels and predict future noise impacts based on planned developments.

J-4.2 Green Belts and Vegetative Buffers

Zonal plans should integrate green belts and vegetative buffers as supplementary noise reduction measures wherever feasible. These green belts should consist of dense rows of trees or shrubs and should be positioned strategically to serve as natural sound barriers.

J-4.3 Building Design Considerations

For buildings located in or near NGZs, zonal plans shall encourage the use of noise-reducing building materials and construction techniques, such as double-glazed windows, soundproofing walls, and appropriate building orientation. For detailed information on noise reduction for town planning schemes, reference may be made to good practice [8-4(2)].

J-5 REGULATION OF NOISE EMISSION SOURCES

J-5.1 Construction Noise Control

Zonal plans shall specify noise control measures for construction sites, including the use of low-noise equipment, temporary barriers, and restricted working hours in NSZs.

J-5.2 Industrial and Commercial Noise Control

Zonal plans shall regulate emissions to ensure that industries and commercial establishments comply with noise limits, monitored periodically for compliance.

J-6 MONITORING AND COMPLIANCE

J-6.1 Noise Monitoring Provisions

Zonal plans shall include provisions for noise monitoring to assess compliance with noise standards. Monitoring stations should be established in key locations within each zone to regularly measure noise levels.

J-6.2 Review and Enforcement

Zonal plans shall be reviewed periodically to ensure the effectiveness of noise abatement measures. Non-compliance with noise regulations should result in penalties, including fines or mandatory implementation of additional noise control measures as per local regulations.

J-7 COMMUNITY ENGAGEMENT AND PUBLIC AWARENESS

J-7.1 Public Consultation

The preparation of zonal plans shall involve public consultation to incorporate community concerns related to noise pollution and to inform stakeholders about proposed noise abatement measures.

J-7.2 Awareness Programs

Zonal plans should include provisions for public awareness programs to educate residents and businesses on noise pollution control practices and compliance requirements.

ANNEX K*(Clauses 3.8.7, 14.4.3, 15 and J-3.2)***DESIGN REQUIREMENTS AND PERFORMANCE EVALUATION OF NOISE BARRIERS****K-1 DESIGN AND GEOMETRY REQUIREMENTS**

K-1.1 The barrier shall be built as close as possible to either the source or receiver. Noise barriers shall be tall enough and long enough to avoid degradations in barrier performance.

K-1.2 Barriers do not necessarily have to be of constant height as varying the height of the barrier may also help to alleviate the monotonous appearance of long length of barriers.

K-1.3 The 'line of sight' between the source and receiver shall be cut off completely by the barrier. Barrier design also plays a major role where effective noise barriers should be high and long enough to break the line-of-sight between the sound source and the receiver.

K-1.4 Capped barriers of same height as conventional barriers may offer greater noise reductions than conventional barriers. A specified noise reduction may be achieved by a capped barrier of lower height than a conventional barrier. If high quality absorptive materials are available, the relative screening performance of cylinder-profile and mushroom-profile caps can be improved, by up to 8 dBA relative to a plane screen of the same overall height. T-profile caps exhibit similar improvement when the uppermost surfaces are treated with the same absorptive materials. Double cylinder-profile caps are comparatively more efficient than single cylinder-profile caps. When absorptive, these provide equivalent average screening performance to T-profile configurations with the same overall height. A 3 m high T-shaped barrier provides the same performance as a 10 m high plain barrier.

K-2 MATERIALS AND CONSTRUCTION

K-2.1 Barriers shall be constructed using solid, non-porous materials having minimum density of 20 kg/m².

K-2.2 The materials used for fabrication of noise barriers include

- a) Steel (painted, galvanized, stainless)
- b) Aluminium
- c) Plastics or polymer sheets concrete
- d) Brick or glass fibre reinforced concrete (GFRC)
- e) Proprietary-made acoustic panels
- f) Landscaped earth berms

K-2.3 Sound absorbing material may be applied on the source side of the barrier to reduce the buildup of sound pressure level. An absorptive treatment may be appropriate to reduce the impact of reflected noise.

K-3 DESIGN MORPHOLOGY AND ADDITIONAL CONSIDERATIONS

K-3.1 Strategic planting may be considered to reduce the monotonous appearance of long length of barriers. The design morphology for noise barriers is shown in Fig. 9.

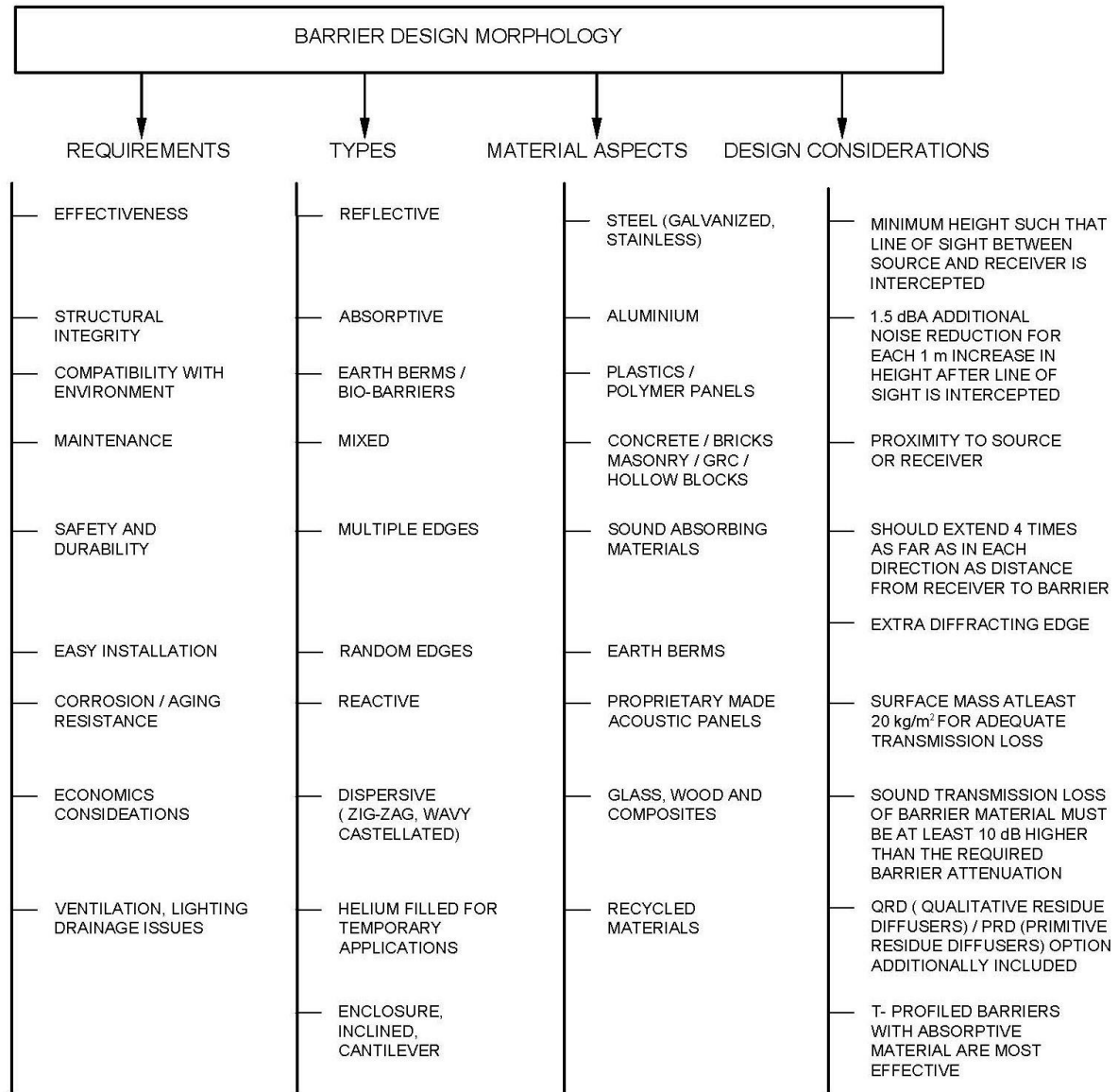

FIG. 9 DESIGN MORPHOLOGY FOR NOISE BARRIERS

K-3.2 The height of a noise barrier is directly proportional to its noise reduction capacity, wherein higher barriers result in greater levels of noise reduction.

K-3.3 The insertion loss for barriers of heights between 3 to 6 m typically ranges between 5 to 12 dB.

K-3.4 Barriers with a thickness exceeding 3 m shall be classified as thick barriers.

K-3.5 Noise barriers may become part of the surrounding landscape over time and can have potential impacts on ecosystems, road users, and residents living alongside the road. The loss of sunlight and visual impact should also be considered while designing the noise barriers.

K-3.6 Special attention shall be given to the selection of materials used in the construction of noise barriers, particularly in areas experiencing extreme weather conditions.

K-3.7 The design of noise barriers should ensure minimal maintenance, except for routine cleaning or repairs due to damage, over the intended lifespan.

K-3.8 The Insertion loss can be estimated by using the Kurze and Anderson model given by the following equation:

- 1) $IL = 5 + 20 \log \left(\frac{\sqrt{2\pi N}}{\tanh \sqrt{2\pi N}} \right)$ dB, upto $N = 12.5$
- 2) $IL = 20$ dB for $N > 12.5$, N is the Fresnel number

Maekawa's curve is one of the most established methods for predicting the insertion loss behind the barriers.

K-4 PERFORMANCE EVALUATION OF NOISE BARRIERS

K-4.1 To ensure the effectiveness of a noise barrier, thorough testing shall be conducted to verify its performance. The intrinsic acoustic properties of the noise barriers are tested as follows:

K-4.2 Diffuse Sound Field Method for Testing Sound Absorption

This method is based on the change of reverberation time inside a reverberation chamber after installing a noise barrier testing sample at the room's surface. This testing method is characterized by a single-number rating of the sound absorption evaluation $DL_{\alpha, \text{NRD}}$, which is described by the following equation:

$$DL_{\alpha, \text{NRD}} = -10 \log_{10} \left[1 - \frac{\sum_{i=1}^{18} \alpha_{\text{NRD}, i} 10^{0.1L_i}}{\sum_{i=1}^{18} 10^{0.1L_i}} \right]$$

where, α_{NRD} is the absorptance of the test sample and L_i is the relative A-weighted sound pressure levels (dB) of the normalized traffic noise spectrum. The classification of $DL_{\alpha, \text{NRD}}$ shall be done on the basis of Table 19.

Table 19 Categories of the Absorptive Performance
(Clause K-4.2)

Category	$DL_{\alpha, NRD}$
(1)	(2)
A0	Not determined
A1	< 4
A2	4 to 7
A3	8 to 11
A4	12 to 15
A5	> 15

The value of $DL_{\alpha, NRD}$ ranges from 0 to 20. $DL_{\alpha, NRD}$ value greater than 8 is required for most highway projects. Close “corridors”, high barriers (>3 m), and reverberant locations require noise barriers with $DL_{\alpha, NRD}$ greater than 12. Figure 10 represents the normalized traffic spectrum in one-third octave band. The spectra is normalized to an overall value of 0 dB as its shape is more important rather than the absolute value.

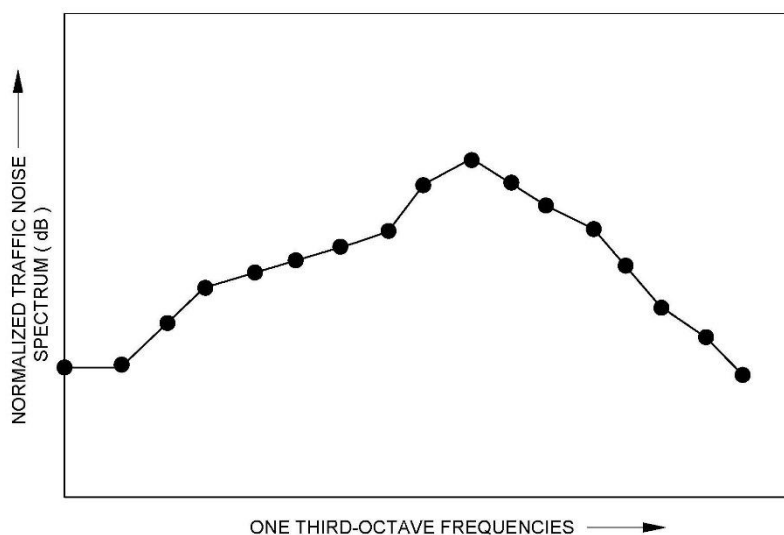

FIG. 10 NORMALIZED TRAFFIC NOISE SPECTRUM (IN dB) AT ONE THIRD OCTAVE FREQUENCY BAND

K-4.3 Diffuse Sound Field Method for Testing Airborne Sound Insulation

In this method, the noise barrier testing sample is inserted in an opening between two adjacent reverberation rooms, the ‘source room’ and the ‘receiving room’. This testing method is characterized by a single number rating, DL_R for summarizing the airborne sound insulation in third-octave bands can be given by:

$$DL_R = -10 \log_{10} \left[\frac{\sum_{i=1}^{18} 10^{0.1L_i} 10^{-0.1R_i}}{\sum_{i=1}^{18} 10^{0.1L_i}} \right]$$

where, R is the airborne sound insulation of the test specimen. Table 20 represents the classification of DL_R .

Table 20 Categories of the Airborne Sound Insulation Performance
(Clause K-4.3)

Category (1)	DL_R (2)
B0	Not determined
B1	= <15
B2	15 to 24
B3	= > 24

B3 is required for the majority of highway developments. B2 may be acceptable for low barriers (less than 2 m), however, the rating level of at least 20 dB is required.

K-4.4 Direct Sound Field Method for Testing Sound Reflection

This method is based on a comparison between the sound energy reflected from the noise barrier and the sound energy emitted towards it. The third-octave band values are then averaged and weighted according to the standardized traffic noise spectrum L_i , to get a single number rating for the NRD as:

$$DL_{RI} = -10 \log_{10} \left[\frac{\sum_{i=1}^{18} RI_i 10^{0.1L_i}}{\sum_{i=1}^{18} 10^{0.1L_i}} \right]$$

where, RI_i is the reflectance in i -th third-octave bands

K-4.5 Direct Sound Field Method for Testing Airborne Sound Insulation

This testing method is based on a comparison between the sound energy arriving at the microphone positions with and without the noise barrier. This testing method is characterized by a single number rating, DL_{SI} . The single-number rating by a weighted average with the standardized traffic noise spectrum L_i is described by:

$$DL_{SI} = -10 \log_{10} \left[\frac{\sum_{i=1}^{18} 10^{0.1L_i} 10^{-0.1SI_i}}{\sum_{i=1}^{18} 10^{0.1L_i}} \right]$$

These single-number ratings can be used for the performance evaluation of noise barriers or noise reducing devices. The *in-situ* method is comparatively more reliable and yields more realistic values than the laboratory method and additionally facilitates fault detection and ascertains the acoustic durability of the NRD.

LIST OF STANDARDS

The following list records those standards which are acceptable as 'good practice' and 'accepted standards' in the fulfilment of the requirements of the Code. The latest version of a standard shall be adopted at the time of enforcement of the Code. The standards listed may be used by the Authority for conformance with the requirements of the referred clauses in this Code. In the following list, the number appearing in the first column within parentheses indicates the number of the reference in this Section.

	<i>IS No.</i>	<i>Title</i>
(1)	11050 (Part 1) : 2023	Rating of sound insulation in buildings and of building elements Part 1 Airborne sound insulation (first revision)
(2)	4954 : 1968	Recommendations for noise abatement in town planning
(3)	2526 : 1963	Code of practice for acoustical design of auditoriums and conference halls
(4)	11050 (Part 1) : 2023 (Part 2) : 2023	Rating of sound insulation in buildings and of building elements Airborne sound insulation (first revision) Impact sound insulation (first revision)
(5)	15575 (Part 1) : 2016 (Part 2) : 2023	Electroacoustics – Sound level meters Specifications (first revision) Pattern evaluation tests (second revision)
