

BUREAU OF INDIAN STANDARDS

DRAFT FOR COMMENTS ONLY

(Not to be reproduced without permission of BIS or used as an Indian Standard)

Draft Indian Standard

Baume Hydrometer - Specification

(*First Revision*)

भारतीय मानक मसौदा

बॉम हाइड्रोमीटर - विशिष्टि

(*पहला पुनरीक्षण*)

ICS 17.060

Glass, Glassware & Laboratoryware Sectional Committee, CHD 10

Last date for Comments: 16 Dec 2022

Foreword

This standard was first published in 1988. This revision is being undertaken, in view of advancement in technology and improvement in accuracy of Hydrometers available in market. In this revision following changes have been made:

- 1) Existing standard covers Hydrometer for only liquid heavier than water however Baume Hydrometers are also commonly used for measuring density of liquids lighter than water. In this revision hydrometer for liquids lighter than water are also covered.
- 2) Dimensions of hydrometer like length and diameter have been modified to accommodate hydrometers of higher accuracy/least count.
- 3) Marking details have been modified. Explanatory note has been modified.

For the purpose of deciding whether a particular requirement of this standard is complied with the final value, observed or calculated, expressing the result of a test or analysis shall be rounded off in accordance with IS 2 : 2022 'Rules for rounding off numerical values (second revision)'. The number of significant places retained in the rounded off value should be the same as that of the specified value in this standard.

Baume Hydrometer - Specification

(First Revision)

1 SCOPE

This Indian standard prescribes requirements and methods of sampling and test for Baume hydrometers meant for determining the strength of aqueous solutions heavier and lighter than water used in various industries.

2 REFERENCES

The following standards contain provisions which, through reference in this text, constitute provisions of this standard. At the time of publication, the editions indicated were valid. All standards are subject to revision and parties to agreement based on this standard are encouraged to investigate the possibility of applying the most recent editions of the standards indicated below.

IS Number	Title
IS 1382: 1981	Glossary of terms relating to glass and glassware (First Revision)

3 TERMINOLOGY

3.1 For the purpose of this standard, the definitions given in IS 1382 in addition to those given below, shall apply.

3.2 Bulb - The wider portion of a hydrometer containing the loading material.

3.3 Stem - The thin tubing attached to the upper part of the bulb containing the indicating scale.

3.4 Degree Baume (° Be) for solution heavier than water at 27°C is given by the following relation:

$$^{\circ}Be = 143.5 - \frac{143}{\text{density at } 27^{\circ}C}$$

4 TEMPERATURE OF CALIBRATION AND RANGE OF SCALE

4.1 Temperature of Calibration - Baume hydrometers shall be calibrated at 27°C.

4.2 Range of Scale –

4.2.1 Baume hydrometers in a set shall cover the entire range from 0 to 70°

Baume in steps of 10 degrees for each hydrometer for liquid heavier than water.

4.2.2 Baume hydrometers in a set shall cover the entire range from 10 to 70°

Baume in steps of 10 degrees or higher accuracy for each hydrometer for liquid lighter than water.

5 SURFACE TENSION

Baume hydrometers shall be graduated on the basis of 'high' surface tension category, that is, 75 mN/m.

6 REFERENCE MARK

6.1 A reference mark consisting of a short horizontal straight line with a 'V' at each end (like >-<) shall be marked on the paper scale, a few millimeters above the topmost graduation mark.

6.2 A fine, clear and permanent line of uniform thickness shall be etched on the stem of the hydrometer coincident with the horizontal portions of the reference mark but slightly longer than the reference mark so that the ends of the etched line project into the 'V' at either end of the reference mark. This arrangement ensures that any displacement of the paper scale is readily apparent.

7 REQUIREMENTS

7.1 Materials

7.1.1 Glass –

The bulb and stem of Baume hydrometers shall be made of colorless transparent glass, resistant to chemicals and thermal shock encountered in use. It shall be as free as possible from strain and visual defects.

7.1.1.1 The recommended coefficient of cubical thermal expansion of glass used in the manufacture of Baume hydrometers is 25.0×10^{-6} per degree Celsius.

7.1.2 Loading material -The loading material shall be confined to the bottom of the bulb. After the instrument has been maintained in a horizontal position for one hour at 80°C and subsequently cooled in that position, it shall meet the requirement of **6.2**.

Note - The use of mercury as a loading material is not permitted.

7.1.2.1 There shall be no loose material whatsoever in any other part of the instrument.

7.2 Pattern, Workmanship and Finish –

Baume hydrometers shall be of a pattern as shown in Fig. 1. They shall be circular in cross-section, robust and symmetrical around the main axis. They shall float vertically in the solutions of appropriate density at 27°C corresponding to their lowest graduation and inclination, if any, from the vertical shall not exceed 1.5°.

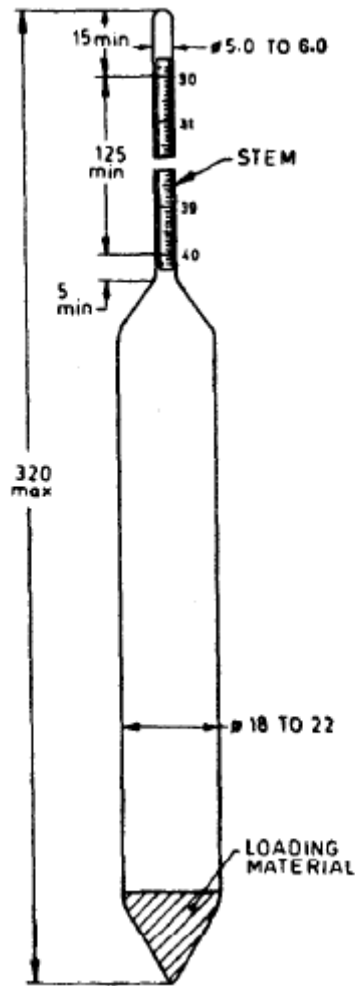

All dimensions in millimeters.

FIG. 1 BAUME HYDROMETER

7.3 Scale –

The scale and the inscriptions shall be marked on a smooth matt surface of white or off-white coloured translucent paper or plastic material. It shall be straight and free from twist. Neither the scale nor the graduations shall distort or discolour when the instrument is maintained at a temperature of 80°C for 24 hours. The hydrometer scale shall be fully enclosed in the hydrometer with all graduation marks clearly visible on the stem.

7.3.1 The graduation lines shall be distinct and of uniform thickness not exceeding 0.2 mm. There shall be no evident local irregularities in their spacing axis of the hydrometer.

They shall be perpendicular to the axis of the hydrometer.

7.3.2 The highest and the lowest graduation lines, indicating the nominal range of the hydrometer shall be long lines and the distance between them shall be divided into 100 equal parts. Thus, the value of the scale interval shall be 0.1° or 0.05° Baume.

7.3.2.1 In addition to above, two to four extra smallest scale divisions shall be marked on either ends of the scale.

7.3.3 The length of long lines shall be not less than half the circumference of the stem, that of medium lines one-third of the circumference, and of short lines one-fifth of the circumference.

7.3.4 *Sequence of graduation lines –*

Every tenth graduation line shall be a long line. There shall be a medium line between two consecutive long lines and four short lines between consecutive medium and long lines.

7.3.5 *Figuring of graduation lines –*

The highest and the lowest graduation lines referring to the nominal range of the hydrometer shall be figured in full. At least every tenth graduation line shall be figured. Graduation lines within the nominal range and the inscription shall be marked in black. Graduation lines outside the nominal range may be marked in colour other than black.

7.4 Dimensions –

The-dimensions of Baume hydrometers shall be as given in Table 1.

TABLE 1 DIMENSIONS FOR BAUME - HYDROMETERS

Sl. No.	Requirements	Values (mm)
i.	Overall length	350, Max
ii.	Length of scale	150, Min
iii.	Diameter of bulb	18, Min 22, Max
iv.	Diameter of the stem	5.0, Min 6.5, Max

(Figure to modified accordingly)

7.4.1 The cross section of the stem shall remain unchanged for at least 5 mm below the lowest graduation line.

7.4.2 The stem shall extend at least 15 mm above the uppermost graduation line on the scale.

7.4.3 The volume of the bulb below the lowest graduation line shall be between 25 and 40 cm³.

7.4.4 Recommended stem diameters for the seven ranges of the hydrometers are given in Table 2 for the guidance of manufacturers.

TABLE 2 RECOMMENDED DIAMETERS FOR BAUME HYDROMETERS

Sl No.	Range of Hydrometer °Baume	Baume Scale	Stem Diameter (mm)
i.	0 – 10		5.0
ii.	10 – 20		5.1
iii.	20 – 30		5.3
iv.	30 – 40		5.5
v.	40 – 50		5.7
vi.	50 – 60		5.9
vii.	60 - 70		6.5

7.5 Accuracy –

The error at any point on the scale of the Baume hydrometer shall not exceed $\pm 0.1^\circ$ Baume.

7.5.1 The accuracy of Baume hydrometers shall be tested in accordance with prescribed in ANNEX A.

8 MARKING AND PACKING

8.1 Marking - The following description shall be legibly and indelibly marked within the hydrometer

- a) Manufacturer's name or its recognized trade-mark, if any;
- b) Calibration temperature, that is, 27°C ;
- c) The basis of the scale, that is ${}^0Be = 143.5 - \frac{143}{\text{density at } 27^\circ\text{C}}$ (on outer packing)
- d) The description, 'In use for liquids heavier than water or lighter than water';
- e) Reference mark; and
- f) Identification mark, if any.

8.2 BIS Certification Marking

The product(s) conforming to the requirements of this standard may be certified as per the conformity assessment schemes under the provisions of the Bureau of Indian Standards Act, 2016

and the Rules and Regulations framed thereunder, and the products may be marked with the Standard Mark

8.3 Packing

Baume hydrometers shall be packed as agreed to between the purchaser and the supplier.

9 SAMPLING

9.1 Representative samples shall be drawn and judged for conformity to this standard as prescribed in IS 3104 (Part 1).

ANNEX A
(Clause-7.5.1)
METHOD -OF TESTING ACCURACY OF BAUME HYDROMETERS

A-1. PRINCIPLE

A-1.1 Accuracy of Baume hydrometers shall be tested by comparison against a similar standardized hydrometer (standardized hydrometer is hydrometer which is calibrated by direct density measurement like using a pycnometer) for routine purposes. However, in case of dispute, this shall be done by verifying the readings of Baume hydrometers by determining the density at 27°C of a liquid with the help of a pycnometer (see IS : 6717 specification for pycnometer'), at appropriate temperature, and converting the value so obtained into degrees Baume.

A-1.2 In the case of testing by comparison, an appropriate solution of known concentration shall be used.

A-2 APPARATUS

A-2.1 A vessel (with an arrangement for overflowing of liquid in such a way that the surface film is constantly removed) shall be used for taking readings of hydrometers. A recommended type of overflow vessel is shown in Fig. 2.

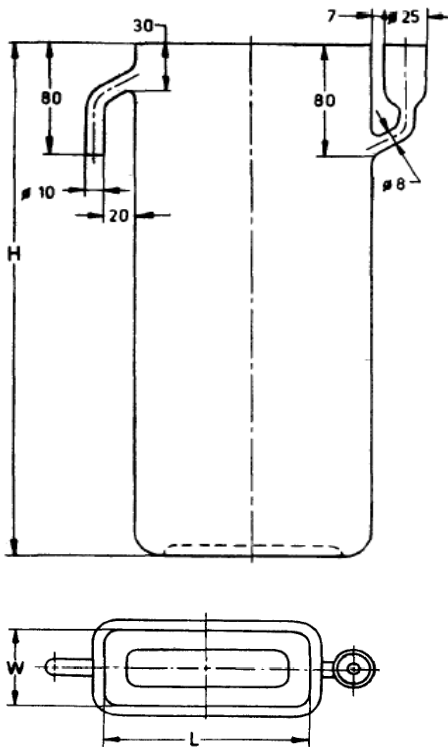

$L = 135 \pm 5 \text{ mm}$
 $W = 55 \pm 3 \text{ mm}$
 $H = 360 \pm 5 \text{ mm}$

All dimensions in millimeters.

FIG. 2 OVERFLOW VESSEL

A-2.2 Thermometer - A solid-stem liquid-in-glass type, of a suitable range and capable of reading with an accuracy of ± 0.1 degree Celsius (*see IS : 4825*).

A-2.3 Pyknometer - 25-ml capacity of Type 4 (*see IS: 5717*).

A-2.4 Water-Bath - capable of maintaining a temperature of 27°C .

A-3 LIQUIDS

A-3.1 Aqueous solution of appropriate liquid in which hydrometer is intended to be used to cover at least four points on the scale of hydrometer.

A-4 PROCEDURE

A-4.1 Comparison Method

A-4.1.1 Pour the appropriate solution of known concentration into the overflow vessel almost to the brim. Stir well to drive out any air bubbles that might be present in it and fill the vessel up. Insert the standardized Baume hydrometer along with the one under test into the solution and allow them to attain the temperature of the liquid. Note the readings of both the hydrometers.

A-4.1.1.1 Any difference in the readings of the Baume hydrometer under test from that of the standardized hydrometer shall be treated as error at that point. Repeat the test to cover at least at four points on the scale.

A-4.2 Pyknometer Method

A-4.2.1 Pour the liquid of which the determination is to be made, in a weighed pycnometer taking due care that no air is entrapped. Allow the level of the liquid to rise slightly above the mark on the neck of the pyknometer. Place the pyknometer in a bath so that it is immersed to a level slightly below the mark. Maintain the bath at 27°C for about half an hour so that the liquid and the pyknometer attain the temperature of the bath. Adjust the liquid level such that the meniscus just touches the mark on the neck of the pyknometer. Remove the pyknometer from the bath, wipe with a dry cloth, dry and weigh to determine the mass of the liquid.

A-4.3 The true mass of the liquid is calculated by adding to the observed mass of the liquid a correction for buoyancy effect of the air. This correction is calculated from the following formula:

$$C = P (V - m/d)$$

Where,

C = correction factor,

p = density of air at the temperature of experiment,

V = volume in ml of the liquid in the pyknometer at 27°C ,

m = observed mass in g of the liquid, and

d = density of the material of weights at the temperature of experiment.

A-4.3.1 Calculate the density of the liquid at 27°C by dividing the mass of the liquid obtained as above, by the volume at 27°C and subsequently find out the equivalent value in degree Baume using the equation:

$$^{\circ}\text{Be} = 143.5 - \frac{143}{\text{density at } 27^{\circ}\text{C}}$$

Any departure from this value, in the reading of the Baume hydrometer for the same solution at 27°C separately, shall be taken as error at the corresponding point on the scale.

EXPLANATORY NOTE

This standard is for Baume hydrometers which are mainly used by salt, chemical, Acids, solvents, and sugar industries for determination of strength of aqueous solutions. Keeping in view the demand from these industries, the Committee decided to formulate this standard. This standard has been prepared on the basis of technical information provided by the National Physical Laboratory,

New Delhi. Baume hydrometers prescribed in this standard are based on the following relations:

a) $^{\circ}Be = 143.5 - \frac{143}{\text{density at } 27^{\circ}C}$

b) $0^{\circ}Be$ which corresponds to pure water has been derived by using the above formula by taking density of water at 27°C as 0.996 511 3 g/cm³,

c) Temperature of calibration has been chosen as 27⁰ C, and

d) Density has been taken as the basis instead of specific gravity keeping in view the present international practices.