

BUREAU OF INDIAN STANDARDS

DRAFT FOR COMMENTS ONLY

(Not to be reproduced without permission of BIS or used as an Indian Standard)

Draft Indian Standard

Method of calibrating liquid-In-Glass thermometers
(*First Revision*)

भारतीय मानक मसौदा

लिक्विड-इन-ग्लास थर्मोमीटर को कैलिब्रेट करने की विधि

(*पहला पुनरीक्षण*)

ICS 17.200.20

Glass, Glassware & Laboratoryware Sectional Committee, CHD 10

Last date for Comments: 21 February 2024

FOREWORD

(Formal clause to be added)

In the preparation of the standard due consideration has been given to the experience gained and practices followed by the National Physical Laboratory, New Delhi in the design, fabrication, testing and use of apparatus in the calibration of liquid-in-glass thermometers. Some of the designs of ice-point equipment and comparator baths (*see* Fig. 1 to Fig. 5) for this purpose have been illustrated in this standard. Details of any specific apparatus may, however, be obtained from the National Physical Laboratory. Similarly, details of comparator bath, illustrated in Fig. 6 may be obtained from the India Meteorological Department, New Delhi. It is hoped the details regarding preparation and use of apparatus and method of taking temperature readings, determination of various corrections and their applications in computing actual temperature will prove very useful to the users, calibrating authorities and manufacturers of liquid-in-glass thermometers.

So far as requirements of accuracy of liquid-in-glass thermometers are concerned, these have already been prescribed in relevant Indian Standards on thermometers.

This standard contains Annex A which is based on an article by J. G. Durham of National Physical Laboratory, Teddington (UK), published in Jour. Sci. Instr. 26 (1949), 205-6. The annex deals with preliminary check of liquid-in-glass thermometers and describes types of faults that may occur in liquid-in-glass thermometers and recommends possible measures to set them right in certain cases.

This standard was originally first published in 1971. And this first revision has been taken up to update the ICS No and several other editorial changes in order to bring out the standard in the latest style and format of the Indian Standards.

Doc. No. CHD 10/24354 WC

IS 6274: 20XX

December 2023

In reporting the results of a test made in accordance with this standard, if the final value, observed or calculated, is to be rounded off, it shall be done in accordance with IS 2 : 2022 'Rules for rounding off numerical values (*second revision*)'.

Draft Indian Standard
Method of calibrating liquid-In-Glass thermometers
(*First Revision*)

1 SCOPE

This standard prescribes the apparatus for and the method of calibrating liquid-in-glass thermometers of total and partial immersion types.

2 REFERENCE

The standards given below contain provisions which through reference in this text, constitute provisions of and necessary adjuncts to this standard. At the time of publication, the editions indicated were valid. All standards are subject to revision and parties to agreements based on this standard are encouraged to investigate the possibility of applying the most recent editions of the standards indicated.

<i>IS No.</i>	<i>Title</i>
IS 1382 : 1981	Glossary of terms relating to glass and glassware (<i>first revision</i>)
IS 2053 : 1974	Specification for thermocouple pyrometers (<i>first revision</i>)
IS 2627 : 1979	Glossary of terms relating to liquid - In - Glass thermometers (<i>first revision</i>)
IS 4825 : 1982	Specification for liquid - In - Glass solid - Stem reference thermometers (<i>first revision</i>)

3 TERMINOLOGY

For the purpose of this standard, the definitions given in IS 1382, IS 2053 and IS 2627 shall apply.

4 PRELIMINARY INSPECTION OF LIQUID-IN-GLASS THERMOMETERS

4.1 General

Before proceeding with the calibration, all thermometers shall be inspected with a magnifying glass, having a linear magnification of at least ten for the following:

- a) *Entrapped Gases* — in the bulb, contraction chamber and expansion chamber;
- b) *Detached Thermometric Liquid* — at the top of the contraction chamber, expansion chamber and in the stem (divided liquid column);
- c) *Impurities in the Bore* — such as dirt and moisture; and
- d) *Bad Shape* — of bulb, contraction chamber and expansion chamber.

4.1.1 In case any one or both of the faults (a) and (b) are observed in any of the thermometers, such samples shall, if possible, be first set right. If, however, these faults still persist or if the thermometers contain any of the faults (c) or (d), such thermometers shall be rejected (*see Annex A*).

4.1.2 In case the graduation lines and figuring on any thermometer have become faint, these shall be made visible by lightly applying graphite or some suitable pigment and wiping the stem with a soft cloth.

4.2 Conditioning of Thermometers

Expose the reference thermometers and the thermometers meant for calibration to the ambient air for at least 30 minutes.

4.2.1 Thermometers having a maximum nominal temperature exceeding 250 °C shall first be placed in a liquid bath maintained at the maximum nominal temperature, for at least 15 minutes and then allowed to rest vertically for at least 8 hours (but not more than 20 hours) in the ambient air before starting calibration.

5 CORRECTIONS APPLICABLE TO THE READINGS OF THERMOMETERS

5.1 The principal corrections applicable to liquid-in-glass thermometers are given below:

- a) Ice-point correction,
- b) Calibration correction, and
- c) Emergent column correction.

5.1.1 These shall be determined as prescribed in 7.1, 7.2 and 7.3, and applied as prescribed in 7.4 for computing actual temperature.

6 APPARATUS FOR CALIBRATING LIQUID-IN-GLASS THERMOMETERS

6.1 General

Apparatus for the calibration of liquid-in-glass thermometers shall be as described below.

6.2 Equipment for Ice-Point Correction

For determining the ice-point correction of thermometers having the smallest scale divisions equivalent to 0.1 °C and above, use is made of an ice-point equipment. For thermometers having smallest scale divisions less than 0.1 °C use is made of a triple-point-of-water-cell which is placed in a large ice-point equipment. Details of these equipments are given below and the method of determination of ice-point correction is prescribed in Annex B.

6.2.1 Ice-Point Equipment

A design (*see* Fig. 1) which has proved satisfactory consists of an insulated vessel provided with an inner, coaxial, perforated cylinder (having length to diameter ratio at least 4 : 1) and a horizontal wire gauge about 5 cm from the bottom. The vessel is provided with a siphon for drawing out water before it reaches the wire gauge. All the parts are made of copper or brass, preferably tin plated to prevent contamination of ice.

NOTE

Vacuum jars and insulated vessels are extensively used for such purpose. But in tropical countries the temperature inside them does not remain stable for sufficiently long periods.

6.2.2 Triple-Point-of-Water Equipment

This consists of a triple-point-of-water-cell (*see* Fig. 2) placed in a large ice-point equipment provided with a suitable cylinder of plastics instead of a perforated cylinder used in 6.2.1. This cylinder is about 5 cm deeper than the triple-point-of-water-cell and the cell fits into it snugly. The cell is made of glass and has dimensions as shown in Fig. 2.

6.3 Equipment for Calibration Correction

For the determination of calibration correction, use is made of comparator baths, also known as thermometer comparators. Comparator baths are made in many different ways, and depending on the range of thermometer to be calibrated, employ different fluids and circulating systems for maintaining as uniform a temperature as possible by cooling or heating as the case may be. In this standard, comparator baths using liquids have been prescribed as such baths are capable of providing greater precision than air-baths or metal blocks. Details of these baths are given below and the method of their test and use is prescribed in Annex C. Details of fluids and circulating systems and methods of heating and cooling employed in comparator baths are given in 6.3.2, 6.3.3 and 6.3.4 respectively.

6.3.1 Comparator Baths

Comparator baths, when tested according to the method prescribed in Annex C, shall be considered satisfactory for the purpose of this standard if the following conditions are fulfilled:

- a) The rise of temperature in a bath during a complete set of observations shall not be more than one-tenth of the smallest scale division of the thermometer under calibration, and
- b) The maximum temperature gradient between the bulbs of thermometers shall not be more than half of the smallest scale division of thermometers being calibrated.

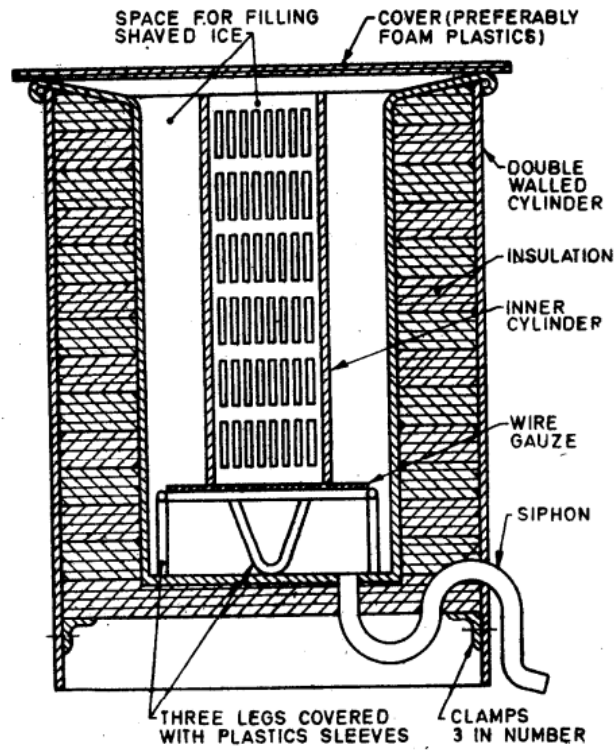
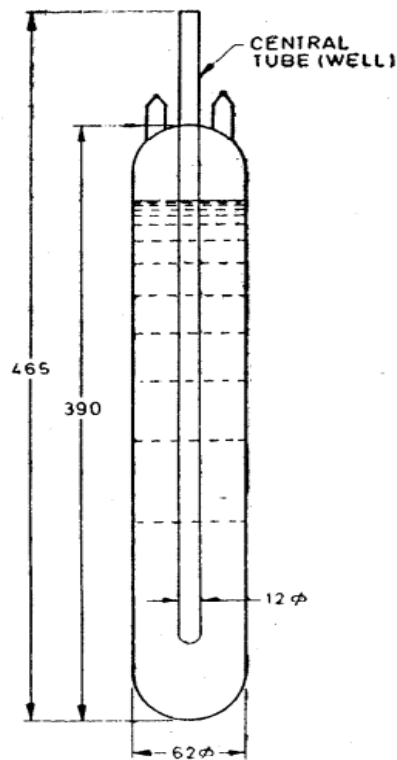

FIG. 1 ICE-POINT EQUIPMENT



All dimensions millimetres.

FIG. 2 TRIPLE-POINT-OF-WATER-CELL

6.3.1.1 Comparator baths which have proved satisfactory consist of a cylindrical vessel (depth to diameter ratio of at least 6 : 1) provided with a stirrer for circulation of liquids and a thermometer cage for carrying the reference thermometers and the thermometers under calibration suspended vertically through the depth of the cylinder. The cage diameter along the thermometers is such that the thermometers remain in half to two-thirds of the space between the stirrer and the inside of the cylinder. Arrangements are provided in the cylinder for rotating the thermometer cage either manually, or otherwise, coaxially with the cylinder. The cylinder of the bath is provided with thermal insulation to a thickness of at least 8 cm on all sides except at the top. The top of the bath is covered with a flange which forms an integral part of the thermometer cage. General details of some of the recommended baths are given in Fig. 3, 4, 5 and 6.

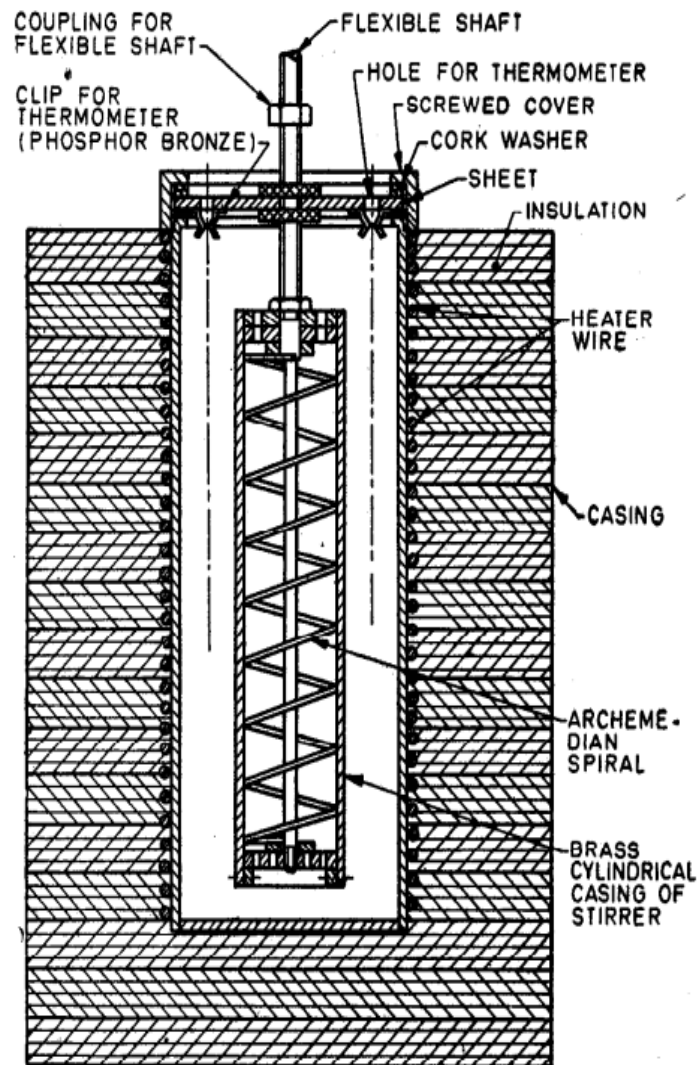

FIG. 3 COMPARATOR BATH, SCREW TYPE

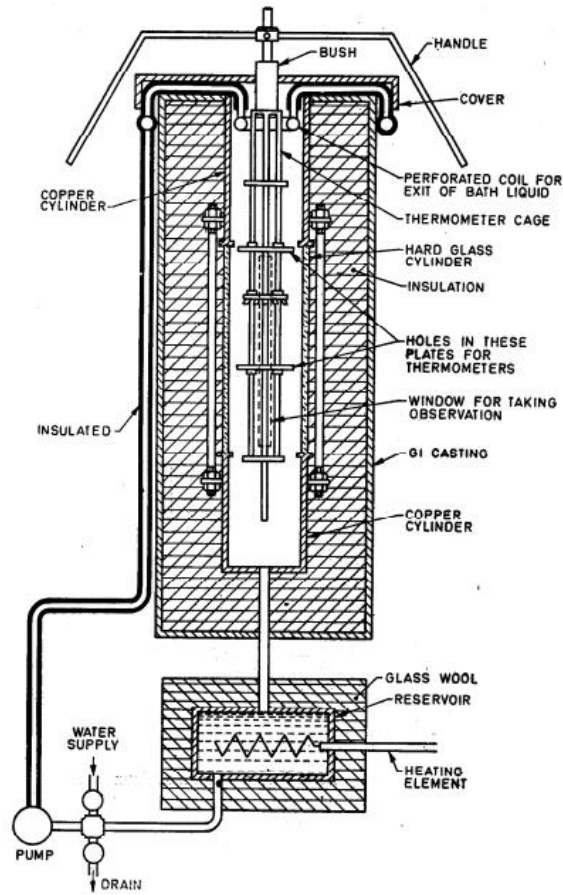

FIG. 4 COMPARATOR BATH, PUMP TYPE

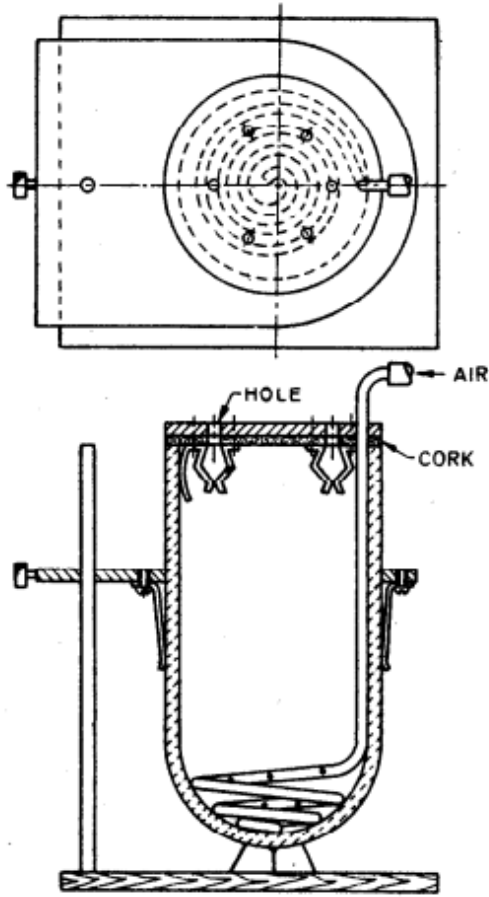

FIG. 5 COMPARATOR BATH, BUBBLER TYPE

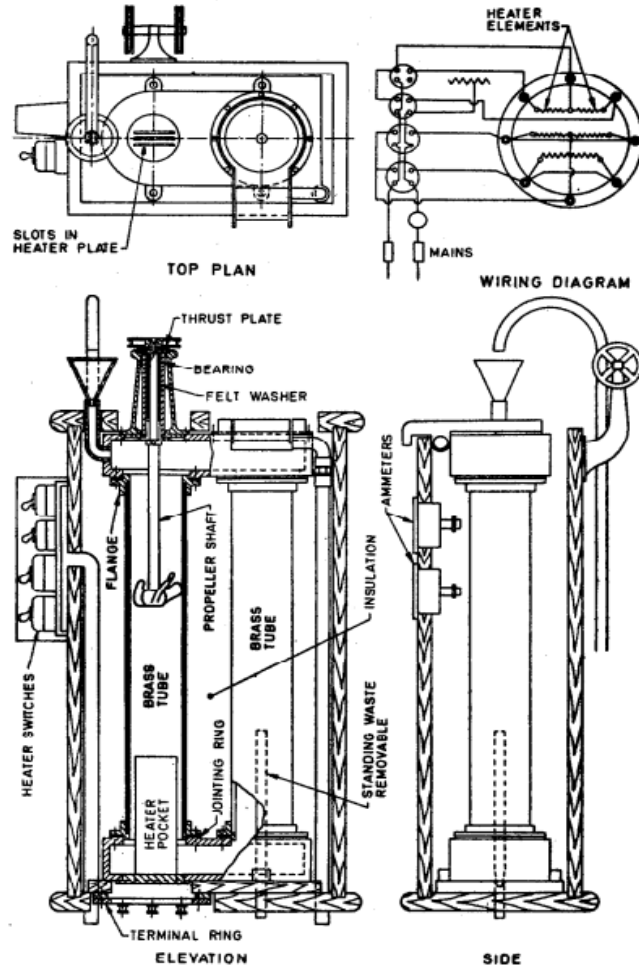

FIG. 6 COMPARATOR BATH, PROPELLER TYPE

6.3.2 Fluids for Comparator Baths

Fluids should be sufficiently mobile, relatively good thermal conductors and non-corrosive to the bath and the glass and pigments generally used for thermometers. The fluids should not produce bubbles and, as far as possible, be non-hazardous in the temperature range in which a particular fluid is used. Recommended fluids which may be used in comparator baths are given in Table 1.

TABLE 1 RECOMMENDED FLUIDS FOR COMPARATOR BATHS

(Clause 6.3.2)

SL No.	RECOMMENDED FLUID	TEMPERATURE RANGE OF USE
(1)	(2)	(3)
		°C
i)	Methyl or ethyl alcohol	- 80 to + 10
ii)	Water	5 to 95
iii)	Transformer oil	95 to 180
iv)	Cylinder oil of flash point above 290 °C	180 to 270

- v) Molten tin or a molten mixture of sodium and potassium nitrates 270 to 600

CAUTION

Molten mixture of sodium and potassium nitrates should not be allowed to fall on organic matter or highly reducing agents to avoid danger of a fire.

NOTES

1 The use of distilled or freshly boiled fluids is recommended to prevent the formation of bubbles while stirring as they hinder observation of readings.

2 The mixture of sodium and potassium nitrates may be prepared by mixing the two salts in ratios 40 : 60 to 60 : 40.

6.3.3 Circulating Systems Used in Comparator Baths

Three types of mechanical circulating systems suitable for different fluids and temperature ranges (*see* Table 1) are described below:

- a) *Screw system* — this is suitable for temperature ranges – 80 °C to + 10 °C, 5 °C to 95 °C, 95 °C to 180 °C and 180 °C to 270 °C;
- b) *Pump system* — this is suitable for all liquids and temperature ranges; and
- c) *Bubbler system* — this is suitable for temperature range – 80 °C to + 10 °C.

Manual stirring may be employed for the temperature range 270 °C to 600 °C. Any other system may also be employed, provided it is so designed that the fluid flows symmetrically with respect to the thermometer cage and the bath satisfies the test prescribed in Annex C.

NOTE

Propeller stirrers (*see* Fig. 6) may also be used as an alternative provided the finished bath satisfies the test prescribed in Annex C.

6.3.3.1 Screw system

In this system an Archimedian screw type stirrer closely fits inside a thin cylinder casing (*see* Fig. 3). This casing is well inside the thermometer cage, coaxial with it. It is positioned in such a way that it is a few centimetres above the bottom of the bath and almost equally below its top. The screw is rotated electrically in such a way that the stirred liquid enters the casing at the top and exits at its bottom. The stirring speed is so adjusted that the bath satisfies the test prescribed in Annex C.

6.3.3.2 Pump system

In this system liquid is pumped from a reservoir through an opening located below the bath and it passes out through a number of jets located at the top of the bath just below the liquid level (*see* Fig. 4). The speed of pumping is so adjusted that the bath satisfies the test prescribed in Annex C.

6.3.3.3 Bubbler system

In this system a tubular ring, provided with a number of fine holes pointing in random directions, is placed inside the bath at the bottom (*see* Fig. 5). This ring is connected to a cylinder of compressed air. The pressure of air is so regulated that the bath satisfies the test prescribed in Annex C.

6.3.4 Heating and Cooling of Comparator Baths

6.3.4.1 General

Heating by electrical means and cooling either by refrigerants or liquefied gases is recommended. The use of thermostats is not recommended as they do not give a uniform temperature in the bath. The best method of obtaining a steady state of temperature is to so adjust the rate of cooling that, with the stirrer 'on' the heat input is just balanced by the heat dissipation.

6.3.4.2 Cooling by directly mixing ice, solid carbon dioxide or other refrigerants is employed for temperatures lower than the ambient temperature. Alternatively, a refrigerant is passed through a cooling coil designed to avoid temperature gradients.

NOTE

Direct mixing of liquid oxygen or liquid air with a combustible liquid like alcohol is not recommended as this may cause an explosion.

6.3.5 Reference Thermometers for Comparator Baths

Only such thermometers as have been compared with national standards and whose deviation from the latter is fully known are to be used as reference thermometers (*see* IS 4825) in a comparator bath. The deviation shall be taken into account while computing temperatures from the readings of such reference thermometers.

6.3.5.1 Reference thermometers for this purpose shall have their smallest scale divisions, smaller than and at the most equal to those of the thermometers under calibration.

6.3.5.2 Two reference thermometers shall be used at a time as a precaution against errors in observation and for detecting any change in their own calibration factors.

7 CALIBRATION OF LIQUID-IN-GLASS THERMOMETERS

7.1 Determination of Ice-Point Correction

Measure the ice-point as prescribed in Annex B after duly conditioning the thermometers (*see* 4.2 and 4.2.1). Note the observations so taken (*see* B-1.2 and B-2.2.2) against the zero degree temperature reading. These shall be duly taken care of in computing the actual temperature from the thermometers.

NOTE

This correction does not apply if the ice (fiduciary) point (0 °C mark) is not given on a thermometer.

7.1.1 In the case of reference thermometers, let the zero reading, that is, the reading of the ice-point of the thermometer be t_2 and the reading of the same point given in a previous calibration report be t_1 [both t_1 and t_2 shall be taken with proper sign, that is, positive (+) if above the zero degree mark and negative (-) if below it]. The ice-point correction Δt shall be expressed as:

$$\Delta t = t_2 - t_1 \text{ degree Celsius}$$

7.1.2 In the case of thermometers under test, the ice-point correction shall be taken as $(- t_1)$ degree Celsius.

7.2 Determination of Calibration Correction

Mount the thermometers a, b, c,l, m, n under test along with reference thermometers s_1 and s_2 on the thermometer cage in a convenient sequence (a) or (b). Adjust the comparator bath temperature to the minimum nominal temperature of the thermometer under test; or to a temperature very near the same. Insert the loaded thermometer cage into the bath. When the system has attained the required temperature, note the readings of the thermometers as quickly as possible in the sequence (a) or (b) as follows:

- a) $s_1, a, b, c, \dots, s_2, l, m, n, \dots, s_1, a, b, c, \dots, s_2, l, m, n, \dots, s_1, a, b, c, \dots, s_2, l, m, n, \dots, s_1, a, b, c, \dots, s_2, l, m, n, \dots, s_1$;
- b) $s_1, a, b, c, \dots, s_2, c, b, a, s_1, a, b, c, \dots, s_2, c, b, a, s_1$

Four sets of readings as above, that is, four readings of each thermometer shall thus be taken.

NOTES

1 The first sequence is convenient when the thermometers are mounted in a vertical cage in the comparator bath and is desirable when the number of thermometers under test exceeds, say, 30. The second sequence of readings is recommended in cases where the thermometers are mounted vertically in the comparator bath along a straight line or along the arc of a circle; the line of arc or circle being in the horizontal plane.

2 Partial immersion thermometers shall be immersed in the comparator bath up to the immersion line or the depth of immersion specified on them, whereas, total immersion thermometers shall be immersed in the bath almost up to the level of the thermometric liquid column. If this is not observed, the gas filled thermometers are likely to get damaged.

7.2.1 Reading of Thermometers

Read the thermometers to one-tenth of the smallest scale division. Optical or other aids may be used for this purpose.

NOTES

1 The various readings of reference thermometers, taken in 4 sets of readings as in 7.2, shall not differ between themselves by more than 1 in the last digit of measurement. If they do, it is indicated that a steady thermal state has not been attained by the equipment and none of the readings shall be taken as indicating the actual temperature.

2 If the various readings of thermometers under test taken in 4 sets of readings alongwith those of reference thermometers, as in 7.2, differ by more than 2 in the last digit of measurement, while the condition as above (*see* Note 1) is satisfied, the observations shall be repeated by another observer. If the readings of the thermometers under test still differ by values more than that mentioned herein, the thermometers shall be taken as not dependable and shall be rejected.

3 In order to reduce time of taking observations to a minimum it is recommended that the readings may be noted by a second observer. If, however, there is only one observer, a tape recorder could be used with advantage.

7.2.2 Recording of Temperature

If the conditions of 7.2.1 are fulfilled and readings are recorded, take the mean of the readings of each of the reference thermometers as well as those under test. Apply correction as explained in 7.1 to the mean values of temperatures thus obtained.

7.2.3 Raise the temperature of the comparator bath gradually and repeat the procedure laid down from 7.2 to 7.2.2 at suitable intervals through the range of thermometers under test.

NOTE

It is essential that every subsequent reading of a thermometer is taken at a higher temperature than the previous one as the temperature of the comparator bath is rising.

7.2.4 Mean of the corrected temperatures of the two reference thermometers shall be taken as the actual temperature of the comparator bath.

NOTE

The corrected temperatures of the two reference thermometers shall not differ between themselves by more than 1 in the last digit of the measurement.

7.2.5 Compute the calibration correction to the readings of the thermometers under test by algebraic subtraction of the mean of their readings, as recorded in 7.2.2, from the actual bath temperatures as computed in 7.2.4. Plot these on a graph paper for each of the thermometers at the different bath temperatures. Draw a smooth curve through the points in such a way as to keep the points of observation nearest to the curve. If the curve leaves out certain points, change the adjustment of the curve till the divergence of the points from the curve is almost identical on both sides of it and at the same time as small as possible, consistent with the possibility of drawing a smooth curve.

7.2.5.1 The readings of the smooth curve shall then be written down at equal temperature intervals as the calibration correction of the thermometers under test.

NOTE

If there are some substantial points of maxima and minima or of inflexion on the curve at temperatures intermediate between those mentioned above, the calibration correction shall also be stated for these temperatures, as these may be due to faults in the bore of the capillary.

7.3 Determination of Emergent Column Correction

7.3.1 General

Total immersion thermometers are calibrated and used under total immersion conditions, that is, they should be immersed in the bath or the medium of which the temperature is to be measured, up to the level of the thermometric liquid column at the time of taking a reading. In case this condition cannot be achieved or if the length of the emergent

column up to the point of the observed temperature, is more than 2 cm, an emergent column correction has to be applied for obtaining actual temperature.

7.3.1.1 Partial immersion thermometers are immersed during calibration and use, up to the depth of immersion or the immersion line marked on them. In practice the temperature of the exposed stem of such thermometers may not be the same as that at the time of their calibration. In such cases emergent column correction has to be applied for obtaining actual temperature.

NOTE

It follows that if the prescribed conditions are obtained in use, this correction is to be treated as zero (0).

7.3.2 For the purpose of determining emergent column correction, the temperature of the exposed stem of the thermometer shall be determined in accordance with the methods prescribed in Annex D and the emergent column correction shall be determined in accordance with the method prescribed in Annex E.

7.4 Computing Actual Temperature

The actual temperature is computed as follows:

$$t = t_0 + \Delta t + t_3 + t_4$$

where,

t = the actual temperature,

t_0 = the observed temperature (*see 7.2.2*),

Δt = the ice-point correction (*see 7.1.1*),

t_3 = the calibration correction (*see 7.2.5.1*), and

t_4 = the emergent column correction (*see 7.3*).

8 LIMIT OF ACCURACY AND STABILITY OF THERMOMETERS

8.1 Limit of Accuracy of Thermometers

The maximum divergence of a point of observation from the smooth curve (*see 7.2.5 and 7.2.5.1*) is calculated. Twice the value of this divergence with a plus-minus (\pm) sign gives the limit of accuracy of the thermometers.

8.2 Stability

The stability of thermometers shall be tested by following the procedure laid down from **7.2** to **7.2.5.1**. The thermometers shall, however, be duly conditioned as prescribed in **4.2** and **4.2.1** both before and after subjecting them for at least 24 hours to a temperature close to their nominal maximum. Thermometers shall be considered as stable if the calibration correction at this temperature does not differ from that obtained in **8.1** by a value greater than the limit of accuracy prescribed for them.

8.2.1 If this condition is not satisfied, the procedure laid down from **7.2** to **7.2.5.1** shall be repeated after at least 4 weeks. If the thermometers fail again, they shall be rejected as being not stable.

NOTE

Thermometers having a range more than 150 °C may be allowed to rest for at least 4 weeks once more and rejected if they still fail.

9 TEST REPORT

The test report of a liquid-in-glass thermometer shall contain the following information:

- a) Identification number of the thermometer and the maker's name and trade-mark;
- b) Nominal range of the main scale;
- c) The value of smallest scale division (least count);
- d) Type of immersion (in case of partial immersion thermometer the depth of immersion in mm) ;

Example — TI for total vertical immersion and PI/150 for partial vertical immersion at 150 mm.

- e) Limit of accuracy of thermometer;
- f) A table showing the actual temperature and calibration correction corresponding to various readings on the thermometer. The table shall give this information for at least 5 readings on the thermometer almost equally spaced and covering the full range of the thermometer;
- g) In the case of partial immersion thermometers, the table shall also indicate the stem temperatures determined against 4 to 6 indications on the thermometer stem, for each reading of the thermometer. It is desirable to so arrange these points of stem temperature measurement that the remotest point from the bulb is round about the ambient temperature;
- h) Type of thermometer (in case it is maximum, minimum or any other type) ; and
- j) Month and year of finishing of test.

ANNEX A
(Clause 4.1.1)

PRELIMINARY CHECK OF LIQUID-IN-GLASS THERMOMETERS

A-1 GENERAL

A-1.1 Liquid-in-glass thermometers often go out of order in transit or when otherwise subjected to undue vibration. The following recommendations summarize the common defects which are likely to appear in such thermometers and possible means of curing them.

A-1.2 It is recommended that use should be made, as far as possible, of methods of adjustment based on cooling rather than heating. If in setting a fault right, it is necessary to move the thermometric liquid into the expansion chamber, particular care should be taken to check against permanent damage, that is, an appreciable zero depression. Similarly, exposure of thermometers to sudden extremes of temperatures or spot heating or cooling should be avoided and only slow and even heating or cooling should be resorted to.

A-1.2.1 Once a thermometer has been set right, it should be handled gently. When not in use, thermometers should be kept in vertical position with bulb downward. In very cold climates, suitable means should be provided to keep the tops of thermometers warm, say at about 50 °C.

A-2 ENTRAPPED GAS

A-2.1 Gas Entrapped in the Bulb

This fault is usually caused by the squareness of the shoulder of the bulb. During manufacture mercury is often drawn down into the bulb by cooling before the bore is filled with gas. When the thermometer has been filled with gas at a suitable pressure, the top & is sealed. If mercury, when cooled, recedes too far into the bulb, any careless shaking or vibration of the thermometer during the gas filling operation may cause bubbles of gas to become entrapped in the bulb, particularly if the shape of the bulb and shoulder is bad. Such a fault also appears if the thermometer has been stored in a very cold place in an orientation which is not vertical. It has been observed that if the bulb joins the capillary in a conical joint this is less likely to occur.

A-2.1.1 Sometimes bubbles of gas entrapped in the bulb are very small and can be detected only by careful examination of the reflection of a bright source of light from the bulb with the aid of a magnifying lens. Serious faults make this look like mist in the bulb.

A-2.1.2 To remove this defect, bubble(s) of entrapped gas should first be tapped into the shoulder of the bulb. The bulb is then cooled by immersion in a cold medium (if necessary solid carbon dioxide) until the whole mercury is sufficiently cooled to enable the entrapped gas to be forced above the mercury. It may be necessary to give the thermometer a slight downward jerk or a gentle tap in order to ensure this. The amount of cooling will depend on the range of the thermometer but the minimum amount of cooling should be tried at first. For instance, thermometers used for determining melting points, having a range, say, 75 °C to 85 °C or 125 °C to 135 °C, may be sufficiently cooled by immersing the bulb in ice shavings. There will, however, be some thermometers which will need cooling with solid carbon dioxide until the mercury in the bulb is practically frozen. *During this operation care must be taken to keep the thermometer with its bulb vertically downwards and to see that it receives no shaking or vibration until after the entrapped gas has been forced above the mercury and it has expanded into the bore.*

A-2.2 Gas Entrapped in the Contraction Chamber

This is seen as a bubble or mist in the contraction chamber. To cure the defect arising from the gas entrapped in the contraction chamber, the mercury can readily be cooled as in **A-2.1.2** until the gas is above the mercury. It is not usually necessary to cool the mercury down into the bulb and it is preferable not to do so.

A-3 DETACHED THERMOMETRIC LIQUID

A-3.1 Detached Mercury at the Top of Contraction Chamber

Shaking will seldom remove detached mercury from the top of the contraction chamber and it is almost always necessary to cool the bulb until the mercury comes down into the contraction chamber in the form of a thin film across it. If the side of the stem near this film is then gently tapped, the detached mercury will form into a globule clinging to the wall of the contraction chamber. The thermometer should then, be kept free from vibration and the bulb warmed either in a bath or by other gentle source of heat until the mercury is joined to the main column.

A-3.2 Detached Mercury in Expansion Chamber (Safety Chamber)

Careful examination is sometimes necessary to detect a globule of mercury in the rounded top of the expansion chamber of a gas filled thermometer, where its appearance can often simulate that of the normal reflexion from the wall of the chamber. A slight tap on the top of the stem will usually dislodge the globule so that it is readily seen. Cooling the bulb will sometimes bring the detached mercury down into the bore, contraction chamber or shoulder of the bulb, where it can be dealt with as already described. It is, however, quite easy to warm the top of the stem using a methylated spirit flame until the detached mercury distils down the bore, where it can be rejoined to the main column by warming the bulb. Care should be taken to see that the heated part of the stem does not touch anything cold so that flaws or cracks do not develop subsequently. Sometimes, these globules can be detached by inverting the thermometer, keeping the expansion chamber in a liquefied gas to solidify the globule and break it off the wall by tapping. The thermometer is then held with bulb downwards, the bulb is heated to join up the column with this globule lying just on the top of the bore. The thermometer is then slowly cooled down in the vertical position.

A-3.2.1 With calorimeter thermometers of the vacuum pattern, there is an alternative method, namely, that of flooding the expansion (safety) chamber where the detached mercury is lodged. Some mercury is warmed into the chamber and then broken off from the main column. Mercury is flooded into the chamber until the detached mercury is jointed to it, and the combined globule is then rejoined to the main column in the manner already described.

A-3.2.2 *Detached Mercury in U-shaped Capillary of Adjustable Range Thermometers (for Example, Beckmann Thermometers)*

For safety in transit the U-shaped capillary at the top of Beckmann type thermometer is frequently filled with mercury almost completely. Before use, it is necessary to rejoin most or all of this mercury to the main column in order to set the zero at the required initial temperature. Normally, this can be carried out by reversing the thermometer and bringing the mercury from the bulb into the bore until it unites with that at the top of the capillary. This method, however, fails when gas is trapped in the mercury. The top of the stem of the thermometer just below the metal cap should, in such a case, be gently warmed by using a methylated spirit flame until the mercury in the U-shaped capillary expands, driving some mercury into the bore should then syphon down into the bulb and fill the bore. All the mercury should then syphon down into the bulb and fill the bore. The trapped gas can then be cleared by the cooling method already described and the thermometer should then be functioning satisfactorily.

A-3.3 Detached Mercury in Stem

Sometimes there are several breaks in the liquid column in the stem. This is called a divided column. Sometimes, but not often, divided columns can be rejoined by shaking the thermometer with a few downward swings, but with gas-filled thermometers the less they are shaken the better. The simplest method is to employ suitable cooling as already described. Some thermometers can be warmed so that the divided column runs up into the safety chamber, when gentle tap against the top of the stem will rejoin the detached globule to the main column. In no circumstances should this method be used unless plenty of time can be allowed to elapse before the thermometer is used again, so as to make sure that it has recovered from any temporary depression of zero caused by the heating of the bulb. If the column gets divided again and again after adjustment, even during storage in vertical position, there is no alternative but to discard the thermometer.

A-3.4 Detached Alcohol in Stem

Spirit thermometers should be carefully stored so as to avoid the breaking up of the column. They should be kept vertical and it is an advantage for their tops to be kept gently warmed to make sure that all detached spirit distils out of the expansion chamber and drains down the walls of the bores and is rejoined to the main columns before the thermometers are put into use. A suitable arrangement is to fix a small electric heater above the racks in which the

thermometers stand so that for a few hours before use, the tops of the thermometers can be kept warm. A temperature of about 50 °C is usually high enough to bring the detached spirit down to the main column. Bubbles of gas trapped in the column of spirit just above the bulb of a thermometer ranging below – 80 °C can be cleared by slowly cooling the bulb in liquid oxygen until most of the spirit is below the shoulder of the bulb. A slight downward swing will bring all the spirit into the bulb and force the gas up the liquid. The spirit in the bulb should then be allowed to expand slowly up the bore.

A-4 IMPURITIES IN BORE

A-4.1 Impurities may be introduced into the bore by unclean or damp mercury or spirit. This must be regarded as a permanent defect in the thermometers.

A-4.1.1 These impurities result in a dirty meniscus or a visible trace in the bore after the liquid has once expanded and then started contracting. Their presence is a sign of poor workmanship or materials and is readily detected. Any adjustment may only affect a temporary improvement and is hardly worthwhile.

A-4.2 Sometimes the column seems to be broken by a gap. It is divided by a slight amount of dampness which has vaporized and formed into a small bubble. Such a bubble moves along the stem as the thermometer bulb is heated or cooled. If the bubble travels faster than the liquid column, it can be driven out by gradually heating the bulb. But if the bubble travels with the same speed as the liquid column, the bulb has to be gradually heated in a bath so as to drive the bubble into the expansion chamber. The chamber is then lightly tapped to join the liquid globules and the thermometer is allowed to stand vertically with bulb downward to cool slowly.

A-4.2.1 If the bubble is very small and does not completely fill the section of the bore, the mercury may be able to pass the bubble without displacing it along the bore. In such cases the fault can be usually rectified by cooling the mercury below the bubble and then vaporizing the liquid above it.

A-5 BAD SHAPE

Recommended shape of the bulb as well as the contraction and expansion chambers is given in the material specifications. Their shape frequently contributes to the causes by which a thermometer may be put out of order. A conical joint between the bulb and capillary tubing is always desirable to avoid possibilities of gas getting entrapped in the bulb.

ANNEX B

(Clauses 6.2 and 7.1)

DETERMINATION OF ICE-POINT CORRECTION

B-1 METHOD USING ICE-POINT EQUIPMENT

B-1.1 Setting Up Ice-Point Equipment

Take some ice and wash it with a liberal supply of clean water. Scrap it over a cutter and collect the shavings into a non-corrosive tray. Transfer the shavings to a clean cotton duster with the help of a brass shovel and wash again to remove any dust and foreign matter.

NOTE

The object of washing the shaved ice is to bring the temperature of every small particle of ice as close to the melting point as possible.

B-1.1.1 Pack the washed ice shavings into the ice-point equipment. Ram the space between the coaxial cylinders as tightly as possible with a poker. Then press the ice shavings in the inner cylinder. Pour water freely into the inner cylinder till the water flowing out of the equipment appears to be perfectly clean and chilled. Again ram the ice shavings in the space between the coaxial cylinders as well as in the inner perforated cylinder. The regelation due to

ramming brings the ice shavings to a temperature slightly lower than that of the pressed ice shavings. Thus, there is some tendency for ice in the inner cylinder to melt.

B-1.1.2 Add more washed ice shavings to top up the ice-point equipment and repeat the operation prescribed in **B-1.1.1** till the equipment is full. Allow the equipment to rest for about 15 to 30 minutes. Press the shaved ice again. The equipment is now ready for use.

B-1.2 Procedure

Take a plastics or glass rod of about the same diameter as the thermometer under test and press it gently, vertically downwards, into the central portion of the inner cylinder, to a depth equal to the length of the thermometer from the bottom of the bulb to the fiduciary point (0 °C mark) on its scale. In any case, however, this depth shall not be more than half the total length of the inner cylinder. Take out the rod and insert the thermometer in its place. Sprinkle a few drops of water around the thermometer. When the temperature indicated by the thermometer has become stationary, note the temperature reading (t_1). This reading (t_1), with sign reversed, shall be taken as the ice-point correction.

B-2 METHOD USING TRIPLE-POINT-OF-WATER EQUIPMENT

B-2.1 Setting Up Triple-Point-of-Water Equipment

Pour a few millilitres of alcohol into the thermometer well in the triple-point-of-water-cell (*see 6.2.2*) duly filled with double distilled, pyrogen free water and sealed. Clean the walls and the bottom of the well with a cotton swab of sterilized surgical cotton, free from loose fibres and attached to a stiff copper wire hook. Remove free alcohol, if any, from the well and plug it with sterilized surgical cotton.

B-2.1.1 Place the triple-point-of-water-cell, cleaned as above, in a vertical position in a refrigerator adjusted to maintain a temperature of 0 °C or a fraction above it, but not below. Allow the cell to remain in the refrigerator till it acquires the above temperature.

B-2.2 Procedure

Quickly transfer the chilled cell from the refrigerator to the plastics cylinder of the ice-point equipment (*see 6.2.2*) prepared as in **B-1.1** and packed with ice shavings in the space between the coaxial cylinders. Quickly pack the thermometer well with dry ice (solid carbon dioxide), a freezing mixture or a liquefied gas in order to freeze a mantle of ice 2 mm to 5 mm thick around and underneath the well. Remove the cooling agent, quickly clean the well with the cotton swab and insert a copper rod (about half the diameter of the thermometer well and long enough to permit easy manipulation). Thus a fine film of melted ice will be formed between the well tube and the ice mantle. Remove the cell from the ice-point equipment for a few seconds and give it a sharp rotatory jerk about its axis. The mantle would begin to revolve around the well tube. Fill the well to about half its height with water previously chilled to 0°C. Put the cell back into the ice-point equipment and allow thermal equilibrium to be attained. The well is now at the triple-point-of-water. Ensure this by seeing that the ice mantle revolves round the well tube on giving a sharp rotatory jerk.

B-2.2.1 Insert the thermometer to be calibrated into the well and allow the temperature to stabilize. Pull the thermometer out a little and note the temperature reading (t_1).

B-2.2.2 The ice-point correction of the thermometer shall be taken as ($t_1 - 0.01$) °C.

ANNEX C

(Clauses 6.3, 6.3.1, 6.3.3, 6.3.3.1, 6.3.3.2 and 6.3.3.3)

METHOD OF TESTING COMPARATOR BATHS

C-1 GENERAL

C-1.1 In testing a comparator bath at least 5 thermocouples (*see IS 2053*) shall be used. The maximum number may be as large as the number of liquid-in-glass thermometers that the thermometer cage carries.

C-1.2 The comparator baths shall be used under exactly the same conditions as are prescribed in **C-2.5** and **C-2.5.1**.

C-2 PROCEDURE

C-2.1 Determine the lowest and the highest positions of the centre of thermometer bulbs when thermometers are mounted on the cage at the time of calibration. Let the positions be (A) and (B) respectively. Mount the thermocouples on the thermometer cage with their temperature sensing junctions at the position (A).

C-2.1.1 Start the bath. Immerse the cage into the bath such that the temperature sensing junctions of thermocouples are at the lowest position (A). When the temperature equilibrium has been attained, record the emf of each thermocouple.

C-2.1.2 Then raise the cage so that the temperature sensing junctions of thermocouples are at the highest position (B). Record the readings of each thermocouple again.

C-2.1.3 Take observations for positions of temperature sensing junctions intermediately between (A) and (B) for conformity.

C-2.2 Heat or cool the bath, as the case may be, at temperature intervals of X °C and repeat all observations as in **C-2.1.1** to **C-2.1.3**.

C-2.3 Repeat the process of **C-2.2** in steps of X °C till the whole temperature range, for which the bath is meant to be used, is covered.

C-2.4 In each of the cases **C-2.1.1** to **C-2.3** ascertain the maximum temperature difference X °C between various combinations of thermocouples.

C-2.5 Depending upon the circulating system employed in the comparator bath, note down the speed of the stirrer or pump or pressure at which gas is being bubbled along with the level of the fluid in the bath while at room temperature.

C-2.5.1 In the case of a salt bath, this level shall be the level of frozen salt after use when it has cooled down to room temperature.

C-3 SUITABILITY OF COMPARATOR BATH

C-3.1 The comparator bath shall be considered to be suitable for calibration of liquid-in-glass thermometers with smallest scale divisions equal to $10 X$ °C or more.

ANNEX D

(Clause 7.3.2)

METHOD OF DETERMINATION OF TEMPERATURE OF EMERGENT THERMOMETER STEM

D-1 GENERAL

D-1.1 Three methods of measuring temperatures along the stem of thermometers have been described in **D-2**, **D-3** and **D-4**. Any one of these may be employed. As there is no correlation between the stem temperatures measured by the three methods, it is necessary to use the same method both while calibrating and using a thermometer. In the case of Methods A and B the ambient conditions shall also be identical both during calibration and use.

D-1.2 The emergent stem temperatures shall be read to within 1 smallest scale division.

D-2 METHOD A — MULTIPLE THERMOMETERS METHOD

D-2.1 General

This method is suitable when the room is thermostated and its volume is very large compared to the volume of the bath and when the bath diameter is large enough to obtain uniform temperatures in a horizontal plane to an extent of 30 cm to 40 cm around the bath.

D-2.2 Procedure

Suspend vertically 5 or 6 thermometers above the bath with their bulbs at different levels along the thermometers being calibrated and covering a horizontal distance of about 10 cm to 15 cm. These thermometers shall be suspended near and not in contact with the thermometers under test.

D-2.3 When a thermometer under test is read, the suspended thermometers are considered to indicate stem temperature at the levels of their bulb centres.

D-3 METHOD B — SINGLE THERMOMETER METHOD

D-3.1 General

This method is suitable when the room is not thermostated, almost unventilated and has a volume very large compared to the bath. In this method a set of thermometers with different bulb lengths is required.

D-3.2 Procedure

When a thermometer is being calibrated or used, take a thermometer having a bulb length nearly equal to that of the exposed stem and tie it to the thermometer under test, keeping the bulb of the former adjacent to the exposed stem of the latter.

D-3.3 When the thermometer under calibration or use is read, the thermometer tied to it shall also be read. The reading of the latter thermometer shall be taken as the mean temperature of the exposed stem.

D-4 METHOD C — THERMOCOUPLE METHOD

D-4.1 General

This method is suitable irrespective of whether the room is thermostated or not; large or small or ventilated or unventilated.

D-4.2 Procedure

Take the required number of calibrated copper advance thermocouples 0.2 mm to 0.3 mm in diameter and cement them suitably to the stem on the back of the thermometer. Note down the temperature indicated by the thermocouples correct to 1 smallest scale division simultaneously with that of the thermometer under calibration or use.

NOTE

The copper wires of thermocouples shall be enamelled. All the leads shall run between a fold of cellotape strip insulation. The junction shall be soldered with pure tin and made into close wound spirals of about 5 turns. The cold junction shall be kept either in an ice-point equipment or a roll of glass wool to keep them at constant temperature.

D-4.3 The temperatures of the thermocouples shall be taken as the stem temperatures at the points where the thermocouples are attached.

ANNEX E (Clause 7.3.2)

DETERMINATION OF EMERGENT COLUMN CORRECTION

E-1 GENERAL

E-1.1 When conditions prescribed in 7.3.1 and 7.3.1.1 are not adhered to the application of emergent column correction becomes necessary. The basic formula for computing this correction is:

$$t_4 = N\alpha(t_0 - t_5)$$

where,

t_4 = the emergent column correction,

N = the number of degrees on the emergent column,

α = apparent coefficient of bulk expansion of the thermometric liquid,

t_0 = the observed temperature, and

t_5 = mean temperature of the-emergent column determined as described in Annex D.

NOTE

Values of α for thermometric liquids are as follows:

a) Mercury or eutectic alloy of mercury with 8.5 percent by mass of thallium	$1.55 \times 10^{-4}/^{\circ}\text{C}$
b) Alcohol	$1.04 \times 10^{-3}/^{\circ}\text{C}$
c) Toluene	$1.03 \times 10^{-3}/^{\circ}\text{C}$
d) Pentane	$1.45 \times 10^{-3}/^{\circ}\text{C}$

E-2 EMERGENT COLUMN CORRECTION FOR TOTAL IMMERSION THERMOMETERS

E-2.1 The method of applying this correction is illustrated by the following example:

Example:

Consider a mercury-in-glass thermometer, having smallest scale division of 0.02 °C giving an observation of 99.584 °C. Let the stem temperature taken as prescribed in Annex D be as given in table 2:

TABLE 2 STEM TEMPERATURE AND GRADUATION MARK

(Clause E-2.1)

SL No. (1)	Graduation Mark, °C (2)	Stem Temperature, °C (3)
i.	95.0	24
ii.	90.0	24
iii.	88.0	27
iv.	86.0	35
v.	84.0	50
vi.	82.0	70

E-2.1.1 As a total immersion thermometer, it should have been immersed in the requisite temperature zone up to the 99.584 °C mark or so. But its 82.0 °C mark is well outside the requisite temperature zone. It can be shown by drawing a graph from the above table that the surface of fluid whose temperature (99.584 °C) is being measured is below the 82.0 °C mark by a distance equal to the stem length of about 1.5 °C, that is, at 80.5 °C. It is, therefore, concluded that the stem temperatures given in table 3 are true to the temperature zone mentioned against each:

TABLE 3 STEM TEMPERATURE AND TEMPERATURE ZONE

(Clause E-2.1.1)

SL No.	Stem Temperature, °C	Temperature Zone, °C
(1)	(2)	(3)
i.	70	81 to 83
ii.	50	83 to 85
iii.	35	85 to 87
iv.	27	87 to 89
v.	24	89 to 91

The stem temperature for 80.5 °C to 81 °C temperature zone is, therefore, midway between 70 °C and 99.6 °C, that is, 84.8 °C while that above 91 °C is at 24 °C. It is to be noted that the stem temperature at 90 °C as well as 95 °C marks is the same, that is, 24 °C so that 24 °C is the ambient temperature. Thus, the stem temperature above 95.0 °C mark is 24 °C.

E-2.1.2 Make a schedule of calculations as shown in Table 4. Columns 1, 2 and 3 are filled up from the above information. The temperature difference in col 4 is that between observed temperature 99.584 °C (or 99.6 °C) and the stem temperature in col 3. Using the value of alpha (α) and the equation given in **E-1.1** and substituting the values given in col 2 and 4 for N and ($t_0 - t_5$) respectively in it, obtain the values for col 5. Summing up the values in col 5, obtain total correction which is 0.1853°C. Adding this to the observed temperature 99.584 °C, obtain the temperature corrected for emergent column correction to the first degree of approximation, that is, 99.769 3 °C or, say, 99.8 °C.

E-2.1.3 Using 99.8°C (approximation of 99.769 3 °C) as the value for obtaining ($t_0 - t_5$) and $N \alpha (t_0 - t_5)$, as shown in col 6 and 7 in Table 4, summing col 7, the total correction obtained is 0.185 9°C. Adding this to the original observed temperature 99.584 °C, obtain the temperature corrected for emergent column correction to a second degree of approximation which comes to 99.769 9 °C or, say 99.8 °C.

E-2.1.4 Repeat this process till either the corrected temperature in two successive approximations happens to be the same or the corrected temperature in a succeeding degree of approximation happens to be less than that in the former, which is not possible and, therefore, untenable. In the example cited above, the second approximation seems to be the last and from its results the value t_4 , can be computed as shown in Table 4. In this case the emergent column correction t_4 is 0.186 °C.

NOTE

If the length of the emergent column is 2 cm to 10 cm, the first degree of approximation (the temperature 99.769 3°C in the above example) of these calculation gives the result accurately. For emergent columns longer than 10 cm or for thermometers with smallest scale division less than 0.02 °C, the above method has to be processed beyond the first degree of approximation.

E-3 EMERGENT COLUMN CORRECTION FOR PARTIAL IMMERSION THERMOMETERS

E-3.1 The method of applying this correction is illustrated by the following example:

Example:

Consider the temperature observed in a partial immersion, mercury-in-glass thermometer, used at prescribed depth of immersion as 152.346 °C. Make a schedule of stem temperature readings as shown in Table 5. The stem temperatures as observed are as given in the calibration report, as shown at SI No. (ii) and (iii) of Table 5. SI No. (iv) is computed by subtracting reported stem temperature from observed stem temperature while SI No. (v) is made up by extending the graduations of stem temperature measurement uniformly on both sides.

TABLE 4 SCHEDULE OF CALCULATIONS FOR TOTAL IMMERSION THERMOMETERS

(Clauses E-2.1.2, E-2.1.3 and E-2.1.4)

INDICATED TEMPERATURE RANGE	TEMPERATURE INTERVAL (N)	STEM TEMPERATURE (FIRST t ₅)	FIRST (t ₀ - t ₅), Where T ₀ = 99.6	COMPUTED FIRST VALUE t ₄ = N × 1.55 × 10 ⁻⁴ (t ₀ - t ₅)	SECOND (t ₀ - t ₅), Where T ₀ = 99.8	COMPUTED SECOND VALUE t ₄ = N × 1.55 × 10 ⁻⁴ (t ₀ - t ₅)	THIRD (t ₀ - t ₅), Where T ₀ = 99.8	COMPUTED THIRD VALUE t ₄ = N × 1.55 × 10 ⁻⁴ (t ₀ - t ₅)
(1)	(2)	(3)	(4)	(5)	(6)	(7)	(8)	(9)
°C	°C	°C	°C	°C	°C	°C	°C	°C
Value of observed temperature t ₀ is 99.584 °C or say 99.6 °C.								
80.5 to 81	0.5	85	14.6	0.001 1	14.8	0.001 1	14.8	0.001 1
81 to 83	2	70	29.6	0.009 2	29.8	0.009 2	29.8	0.009 2
83 to 85	2	50	49.6	0.015 4	49.8	0.015 4	49.8	0.015 4
85 to 87	2	35	64.6	0.020 0	64.8	0.020 1	64.8	0.020 1
87 to 89	2	27	72.6	0.022 5	72.8	0.022 6	72.8	0.022 6
89 to 91	2	24	75.6	0.023 4	75.8	0.023 5	75.8	0.023 5
91 to 99	8	24	75.6	0.093 7	75.8	0.094 0	75.8	0.094 0
Total correction				0.185 3		0.185 9		0.185 9
Corrected temperature, that is, 99.584 + total correction				99.769 3 °C		99.769 9		99.769 9
Reading corrected for exposed stem only (99.7699)						99.770 °C		
Reading without correction for exposed stem						99.584 °C		
Emergent column correction (t ₄)						+0.186 °C		

TABLE 5 SCHEDULE OF STEM TEMPERATURE READINGS FOR PARTIAL IMMERSION THERMOMETERS

(Clause E-3.1)

SL No.	PARTICULARS	DETAILS					
(1)	(2)	(3)	(4)	(5)	(6)	(7)	(8)
i)	Graduations at which the stem temperature are measured, °C	20	50	80	110	140	170
ii)	Stem temperature observed at the time of use (t ₀), °C	110	76	60	48	40	35
iii)	Stem temperature reported in test report (t ₅), °C	110	80	52	31	25	25

iv)	Temperature observed minus temperature reported ($t_0 - t_5$) °C	- 9	- 4	8	17	15	10
v)	Data application in the temperature range(°C)	5 to 35	35 to 65	65 to 95	95 to 125	125 to 155	155 to 185

E-3.1.1 The distance of immersion line from 20 °C mark can be measured, let this length be equivalent to 40 degree Celsius. Therefore, virtually the immersion line is at a mark corresponding to - 20 °C. It would, thus, appear that the stem temperature between -20 °C and 5 °C marks is not known. This can be computed graphically by extrapolating other temperatures of SI No. (ii) and (iii). This gives the values of ($t_0 - t_5$) as -7 °C at the mid position between immersion line and +20 °C mark and $N = 25$ °C. Moreover, no correction is desirable beyond observed reading 152.346°C (say 152.3°C) as the mercury column does not exist there.

E-3.1.2 Collecting up this data and applying the formula given in **E-1.1**, the corrections as given in Table 6 are obtained.

TABLE 6 CALCULATION OF EMERGENT COLUMN CORRECTION FOR PARTIAL IMMERSION THERMOMETER

(Clause E-3.1.2)

SL No.	AROUND GRADUATION	N	($t_0 - t_5$)	$T_4 = N.\alpha (t_0 - t_5)$
(1)	(2)	(3)	(4)	(5)
i)	0	25	-7	-0.027 1
ii)	20	30	-9	-0.041 8
iii)	50	30	-4	-0.018 6
iv)	80	30	8	+0.037 2
v)	110	30	17	+0.079 1
vi)	140	27.3	15	+0.063 5
Total emergent column correction (t_4) =				+ 0.092 3 °C