

BUREAU OF INDIAN STANDARDS

DRAFT FOR COMMENTS ONLY

(Not to be reproduced without permission of BIS or used as an Indian Standard)

भारतीय मानक मसौदा
**जूते के लिए हील-टिप और
टो-टिप की कील — विशिष्टि**
(IS 8060 का पहला पुनरीक्षण)

Draft Indian Standard

**HEEL-TIP AND TOE-TIP WITH NAILS
FOR FOOTWEAR — SPECIFICATION**

(First Revision of IS 8060)

(ICS 61.060)

Footwear Sectional Committee, CHD 19

Last Date for Comments: 06.07.2024

Footwear Sectional Committee, CHD 19

FOREWORD

(Formal clause will be added later)

Heel-tips and toe-tips are important footwear accessories. They are used in industrial and safety leather boots and other types of ankle boots for heavy duty and general purposes.

This standard was originally published in 1976. This revision has been taken up in order to bring out the standard in latest style and format of the Indian Standards. The Reference clauses has been added and the references has been updated.

For the purpose of deciding whether a particular requirement of this standard is complied with, the final value, observed or calculated, expressing the result of a test or analysis, shall be rounded off in accordance with IS 2: 2022

'Rules for rounding off numerical values (*second revision*)'. The number of significant places retained in the rounded off value should be the same as that of the specified value in this standard.

Draft Indian Standard

**HEEL-TIP AND TOE-TIP WITH NAILS
FOR FOOTWEAR — SPECIFICATION**
(First Revision)

1 SCOPE

This standard prescribes the requirements and method of sampling for heel-tip and toe-tip with nails intended for use in footwear.

2 REFERENCES

The Indian standards given below contain provisions which through reference in this text, constitute provisions of this standard. At the time of publication, the editions indicated were valid. All standards are subject to revision, and parties to agreements based on this Indian standard are encouraged to investigate the possibility of applying the most recent editions of the standards:

<i>IS No.</i>	<i>Title</i>
IS 1573 : 1986	Specification for electroplated coatings of zinc on iron and steel (<i>second revision</i>)
IS 2050 : 1991	Glossary of terms & relating to footwear (<i>first revision</i>)
IS 2633 : 1986	Method for testing uniformity of coating on zinc coated articles (<i>second revision</i>)
IS 4905 : 2015	Random sampling and randomization procedures (<i>first revision</i>)

3 TERMINOLOGY

For the purpose of this standard, definition given in IS 2050 shall apply.

4 REQUIRMENTS

4.1 Heel-tip and toe-tip shall be made of rust-proofed mild steel. The treatment for rust-proofing shall be as given in **4.1.1**.

4.1.1 After manufacture the tips shall be either electroplated with zinc to service condition No. 4 of IS 1573 or hot-tip galvanized conforming to IS 2633.

4.2 Heel-tip and toe-tip shall conform to the shape and design shown in Fig 1.

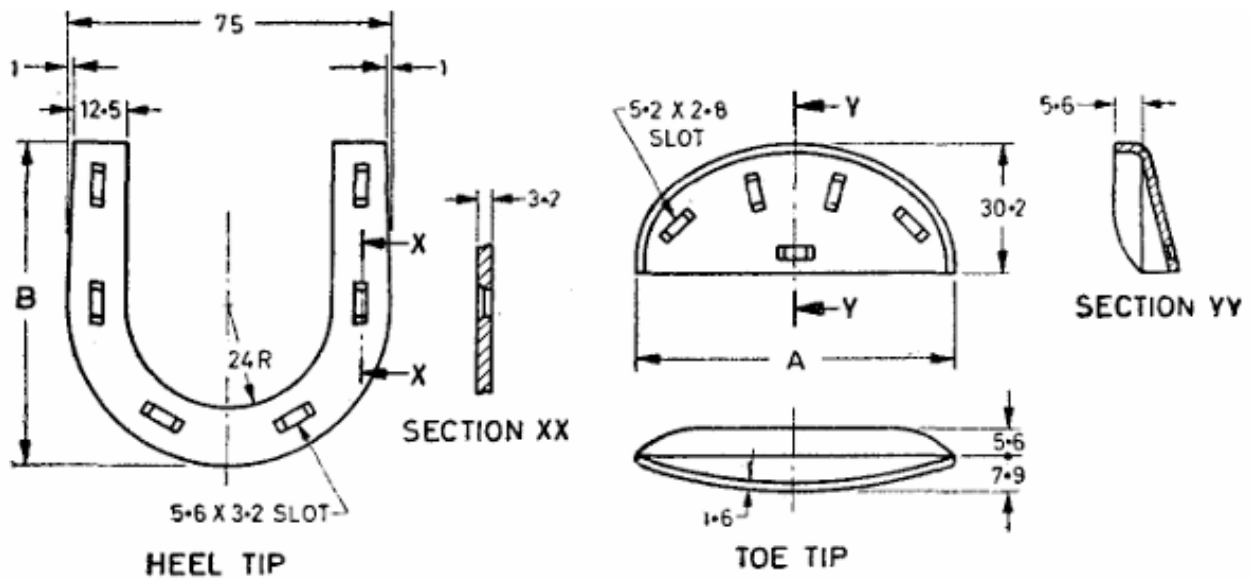

All dimensions in millimetres.

FIG. 1 HEEL-TIP AND TOE-TIP

4.3 Dimensions

4.3.1 Heel-tip and toe-tip shall conform to the dimensions given in Fig. 1 and Table 1.

TABLE 1 DIMENSION OF HEEL-TIP AND TOE-TIP

(Clause 4.3.1)

Sl. No	Boot or Shoe Size	Dimension, mm	
		B for Heel-Tip	A for Toe-Tip
(1)	(2)	(3)	(4)
i)	3 to 5	73	70 to 73
ii)	6 to 7	76	73
iii)	8 to 9	79	76
iv)	10 to 11	82.5	79
v)	12 to 14	86	82.5

4.3.3 Tolerance — A tolerance of ± 1 mm shall be allowed on the length and ± 0.25 mm on other dimensions of the heel-tip and toe-tip.

4.4 Heel-Tip Nail and Toe-Tip Nail

4.4.1 Heel-tip nail and toe-tip nail shall be made of rust-proofed mild steel. The treatments for rust-proofing shall be as given in 4.1.1.

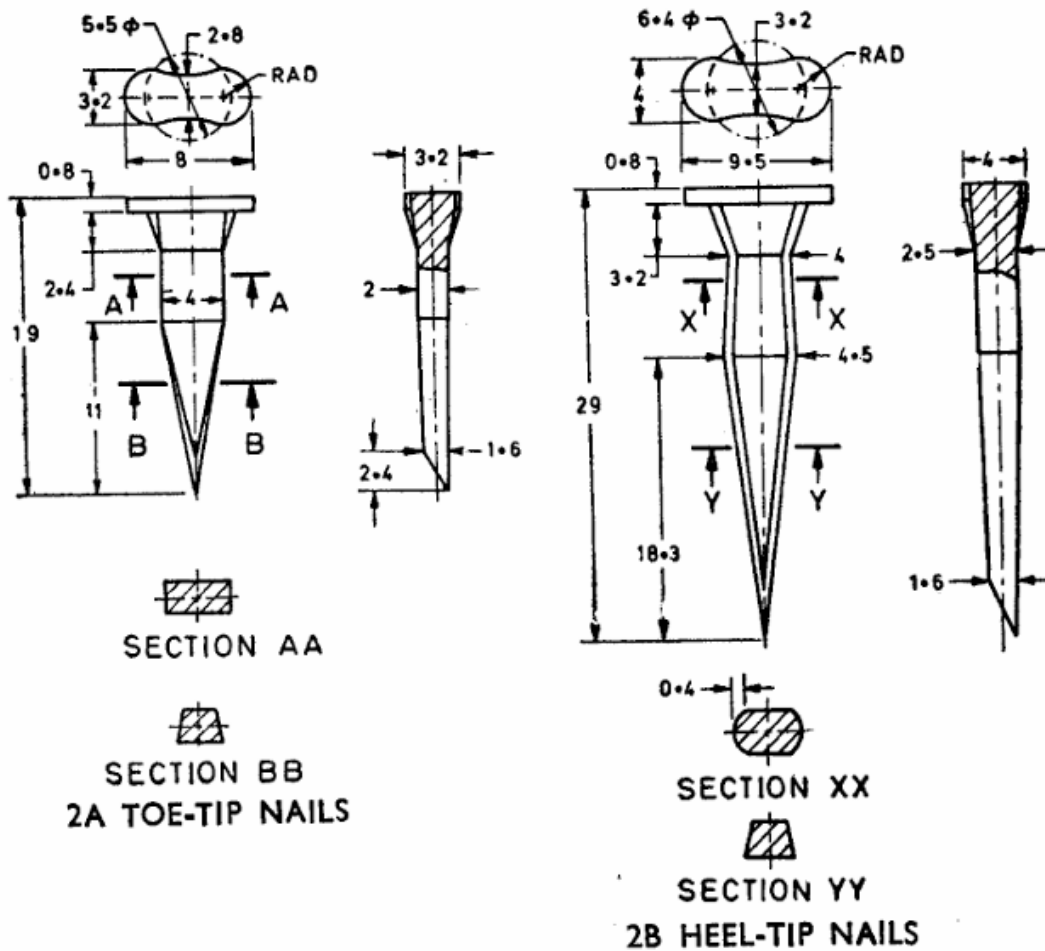

All dimension in millimetres.

FIG. 2 TOE-TIP AND HEEL-TIP NAILS

4.4.2.1 Tolerance — The following tolerance shall be allowed on the various dimensions:

Length	± 1.6 mm
other dimensions except for the tip and thickness of head	± 0.25 mm
thickness of head	± 0.1 mm

5 PACKING AND MARKING

5.1 Packing

5.1.1 Heel-tip and toe-tip shall be packed in suitable containers as agreed to between the purchaser and the supplier.

5.1.2 Heel-tip nail and toe-tip nail shall be packed in suitable containers as agreed to between the purchaser and the supplier.

5.1.3 Each container shall be marked with the following:

- a) Name of the material;
- b) Size and quality;
- c) Batch number;
- d) Manufacturer's name and recognized trade-mark, if any; and
- e) Date of manufacture.

5.2 Marking

5.2.1 BIS Certification Marking

The product(s) conforming to the requirements of this standard may be certified as per the conformity assessment schemes under the provisions of the *Bureau of Indian Standards Act, 2016* and the Rules and Regulations framed thereunder, and the products may be marked with the standard mark.

6 SAMPLING

The method of drawing representative samples and the criteria for conformity shall be as prescribed in Annex A.

ANNEX A

(Clause 6)

SAMPLING OF HEEL-TIP AND TOE-TIP WITH NAILS

A-1 SCALE OF SAMPLING

A-1.1 Lot

All tips and nails of the same size, shape, and similar dimensions in a consignment shall be grouped together to constitute a lot.

A-1.2 The conformity of tips and nails to the requirements of this specification shall be ascertained for each lot separately. The number of tips and nails to be selected from each lot shall depend on the size of the lot and shall be in accordance with col 1 and 2 of Table 2.

A-1.3 These tips and nails shall be selected at random from the lot. In order to ensure the randomness of selection, random sampling procedures given in IS 4905 may be followed. If the tips and nails are packed in a number of containers, at least 20 percent of them shall be opened and equal number of tips and nails shall be selected from each container to constitute the required sample.

TABLE 2 SCALE OF SAMPLING AND PERMISSIBLE NUMBER OF DEFECTIVE TIPS AND NAILS

(Clauses A-1.2 and A-2.1)

Sl. No	Lot Size	No. of Tips and Nails to be Selected	Permissible Number of Defectives
	N	n	
(1)	(2)	(3)	(4)
i)	Up to 1 000	5	0
ii)	1 001 to 3 000	8	0
iii)	3 001 to 5 000	13	0
iv)	5 001 to 10 000	20	1
v)	10 001 and above	32	1

A-2 NUMBER OF TESTS AND CRITERIA FOR CONFORMITY

A-2.1 All tips and nails selected under **A-1.2** shall be examined for rust-proofness of mild steel, shape, design and dimensions (**4.1**, **4.2**, **4.3** and **4.4**). A tip or a nail failing to satisfy any of these requirements shall be considered as defective. The lot shall be accepted as conforming to the requirements of this specification if the number of defective tips and nails found in the sample does not exceed the respective permissible number of defective tips and nails given in col 4 of Table 2.