



भारतीय मानक ब्यूरो BUREAU OF INDIAN STANDARDS

MANAK BHAVAN, 9 BAHADUR SHAH ZAFAR MARG, NEW DELHI 110002

व्यापक परिचालन मसौदा

13/09/2023

हमारा संदर्भ: ईटीडी 32/टी-1

तकनीकी समिति: विद्युत उपकरण अनुभागीय समिति, ईटीडी 32

प्राप्तकर्ता :

- क) विद्युत तकनीकी विभाग परिषद्, ईटीडीसी के सभी सदस्य
- ख) ईटीडी 32 के सभी सदस्य
- ग) रूचि रखने वाले अन्य निकाय

महोदय/महोदया,

निम्नलिखित भारतीय मानक का मसौदा संलग्न है:

प्रलेख संख्या	शीर्षक
ईटीडी 32 (23559)WC/ IS 4250 का पुनरीक्षण	विद्युत भोजन - मिक्सर (लिट्रिडाइज़र और ग्राइंडर) और सेंट्रीफ्यूगल जूसर के लिए विशिष्टता का भारतीय मानक मसौदा ICS: 97.040.50

कृपया इस मानक के मसौदे का अवलोकन करें और अपनी सम्मतियाँ यह बताते हुए भेजे कि यदि यह मानक के रूप में प्रकाशित हो तो इस पर अमल करने में आपके व्यवसाय अथवा कारोबार में क्या कठिनाइयाँ आ सकती हैं।

सम्मतियाँ भेजने की अंतिम तिथि : 13/11/2023

सम्मति यदि कोई हो तो कृपया अधोहस्ताक्षरी को उपरिलिखित पते पर संलग्न फॉर्मेट में भेजें या eetd@bis.gov.in पर ईमेल कर दें।

यदि कोई सम्मति प्राप्त नहीं होती है अथवा सम्मति में केवल भाषा सम्बन्धी त्रुटि हुई तो उपरोक्त प्रलेख को यथावत अंतिम रूप दिया जाएगा। यदि सम्मित तकनीकी प्रकृति की हुई विषय समिति के अध्यक्ष के परामर्श से अथवा उनकी इच्छा पर आगे की कार्यवाही के लिए विषय समिति को भेजे जाने के बाद प्रलेख को अंतिम रूप दे दिया जाएगा।

यह प्रलेख भारतीय मानक ब्यूरो की वेबसाइट www.bis.gov.in पर भी उपलब्ध है।

धन्यवाद।

भवदीय,

(प्रीति भटनागर)
प्रमुख (विद्युत तकनीकी विभाग)

संलग्नक : उपरिलिखित

**भारतीय मानक ब्यूरो**
BUREAU OF INDIAN STANDARDS

MANAK BHAVAN, 9 BAHADUR SHAH ZAFAR MARG, NEW DELHI 110002

DRAFT IN WIDE CIRCULATION

13/09/2023

Our Ref: ETD 32/T-1

TECHNICAL COMMITTEE: Electrical Appliances Sectional Committee, ETD 32

ADDRESSED TO:

- All Members of Electrotechnical Division Council, ETDC
- All Members of ETD 32
- All others interests.

Dear Sir/Madam,

Please find enclosed the following document:

Doc No.	Title
ETD 32 (23559)WC/ Revision of IS 4250	DRAFT INDIAN STANDARD OF SPECIFICATION FOR ELECTRIC FOOD – MIXERS (LIQUIDIZERS AND GRINDERS) & CENTRIFUGAL JUICERS (SECOND REVISION) ICS: 97.040.50

Kindly examine the draft standard and forward your views stating any difficulties which you are likely to experience in your business or profession if this is finally adopted as National Standard.

Last Date for Comments: **13/11/2023**

Comments if any, may please be made in the attached format and mailed to the undersigned at the above address or preferably through e-mail to eetd@bis.gov.in.

In case no comments are received or comment received are of editorial nature, you may kindly permit us to presume your approval for the above document as finalized. However, in case of comments of technical in nature are received then it may be finalized either in consultation with the Chairman, Sectional Committee or referred to the Sectional Committee for further necessary action if so desired by the Chairman, Sectional Committee.

The document is also hosted on BIS website www.bis.gov.in.

Thanking you,

Yours faithfully,

(Priti Bhatnagar)
Head (Electrtechnical Dept.)

Encl: As above

BUREAU OF INDIAN STANDARDS

DRAFT FOR COMMENTS ONLY

(Not to be reproduced without the permission of BIS or used as an Indian Standard)

Draft Indian Standard

**SPECIFICATION FOR ELECTRIC FOOD – MIXERS
(LIQUIDIZERS AND GRINDERS) & CENTRIFUGAL JUICERS**

ICS: 97.040.50

Electrical Appliances
Sectional Committee, ETD 32

Last date of Comments:
13/11/2023

FOREWORD

This Indian Standard (Second Revision) would be adopted by the Bureau of Indian Standards, on recommendation of the Electrical Appliances Sectional Committee and approval of the Electrotechnical Division Council.

This standard was originally published in 1967 and subsequently revised in 1980.

The second revision has been undertaken due to the following:

- a) To align the safety requirements with the latest version of IS 302-2-14 Safety of household and similar electrical appliances: Part 2 particular requirements: Sec 14 electric kitchen machines.
- b) New methodology for endurance test of motors is added.
- c) No limitations on the power input value.

For the purpose of deciding whether a particular requirement of this Standard is complied with the final value, observed or calculated expressing the result of a test or analysis shall be rounded off in accordance with IS 2 : 1960 'Rules for rounding of numerical values (revised)'. The number of significant places retained in the rounded off value should be the same as that of the specified value in this Standard.

*Indian Standard***SPECIFICATION FOR ELECTRIC FOOD-MIXERS
(LIQUIDIZERS AND GRINDERS) AND CENTRIFUGAL JUICERS
(Second Revision)****1. SCOPE**

This standard covers electric motor-driven food-mixers (grinders and liquidizers) and centrifugal juicers intended for household and similar use and designed for operation at voltages not exceeding 250 V.

Any other attachments agreed between the buyers and manufacturers are also covered within the scope of this standard provided it meets all the relevant requirements mentioned in the standard e.g blenders, food processor attachment etc.

Multipurpose machines that are used together with certain accessories are also covered by this standard as far as it applies.

2 REFERENCES

The standards listed below contain provisions which, through reference in this text, constitute provisions of this standard. At the time of publication, the editions indicated were valid. All standards are subject to revision, and parties to agreements based on this standard are encouraged to investigate the possibility of applying the most recent editions of these standards.

<i>IS No.</i>	<i>Title</i>
302 (Part 1):2008	Safety of household and similar electrical appliances: Part 1 General requirements
302(Part 2/Sec 14):2009	Safety of household and similar electrical appliances: Part 2 Particular requirements, Section 14 Electric kitchen machines (<i>first revision</i>)
460 (Part 1) : 2020	Test Sieves — Specification Part 1 Wire Cloth Test Sieves (Fourth Revision)
3077 : 2022	Roasted and ground coffee - Specification

3 TERMINOLOGY

3.1 For the purpose of this standard, the following definitions, in addition to those given in 3 of IS 302(Part 2/Sec 14) shall apply.

3.2 Food-mixer

Appliance intended for mixing food ingredients.

Note- A appliance that can do the functions indicated in 3.3 and 3.4.

3.3 Grinder

A portable appliance which by operation of high-speed blades or cutters is intended primarily for pulverizing or powdering dry foodstuffs either raw or roasted, such as coffee seeds, cereals, grains, etc.

3.4 Liquidizer

A portable appliance that by operation of high-speed blades or cutters is designed either for mixing liquids or for converting foods with or without the presence of water (or vegetable oils) depending on the type of food, into forms of slurry or pulps.

3.4.1 Blender

Appliance intended to pulverize solids, such as ice, vegetables, or fruit, and to combine them into a blend, or to merge liquids and solids into a blend (food blenders) or to combine liquids only (liquid blenders).

3.4.2 Food processor attachments

Attachments intended to finely chop batches of meat, cheese, and vegetables by means of cutting blades rotating in a container and meant for Wheat Flour Kneading.

Note: One or more of attachments doing functions such as chopping, kneading, grating, slicing, etc. are examples of the food processor attachments.

3.5 Centrifugal Juicer

An appliance or attachment designed to extract juice from fruits or vegetables by cutting into pieces and by centrifugal action.

3.6 Cycle of Operation

The operations of juice extraction, dismantling for removal of fluff (waste), cleaning and reassembly.

3.7 Batch Operation

The operation of a juicer where the quantity of input of the fruits or vegetables is limited by the capacity of the vessel provided for the collection of either the juice extracted or the fluff (waste) without overflowing.

3.8 Continuous Operation

The operation of a juicer where the quantity of input of the fruits or vegetables is not limited by the capacity of the vessel provided for the collection of either the juice extracted or the fluff (waste).

3.09 Rated Capacity

The rated capacity declared by the manufacturer shall be the maximum specified quantity handled by the unit for each complete cycle of operation.

3.10 Rated Input

The rated input shall be the maximum power drawn by the unit. The value shall be declared by the manufacturer.

3.11 Normal load

3.11.1 - For the food mixers - Denotes the load obtained when the appliance is operated under the load indicated in the instruction's booklet in terms of recipes (can be different for grinder and Liquidizer) or the load necessary to attain the rated input (including the tolerance) at the rated voltage in case the actual load in terms of recipes is not indicated by the manufacturer in the instruction's booklet.

NOTE— In case the input differs with various kinds of recipes indicated in the instruction's booklet, the normal load shall correspond to the highest input.

3.11.2- For the Juicers

Normal Load — The load necessary to attain rated input at rated voltage when the rated input is marked on the juicer or the load obtained when the appliance is operated under the conditions given below:

- a) For juicers for batch operation; for ten periods during each of which the juicer is supplied with 0.5 kg of carrots or fresh seasonal fruits for 2 minutes unless otherwise indicated in the manufacturer's instruction sheet with a test period of 2 minutes between each;
- b) For juicers for continuous operation; for 30 minutes, the juicer is supplied gradually with 5 kg of carrots or fresh seasonal fruits.

The pusher if any, is pressed with a force of 5 N against the carrots.

The carrots are soaked in water for approximately 24 hours before the test is started.

3.12 Nominal Capacity

The nominal capacity or capacity shall be the maximum specified quantity of the vessels. This value shall be declared by the manufacturer.

4 GENERAL REQUIREMENTS

4.1 The relevant provisions of 4 of IS 302 (Part 2/Sec 14) shall apply in addition to **4.2**.

4.2 The external finished used on metal components shall be of heat and moisture-resisting nature and shall not be adversely affected by variations in temperature occurring under normal operating conditions or during the endurance test. The external finish of the body of the food mixer shall not become stained due to spillage of foodstuff from the bowl of the food mixer.

5 GENERAL CONDITIONS FOR THE TESTS

5.1 The relevant provisions of 5 of IS 302 (Part 2/Sec 14) shall apply except as stated otherwise in individual tests.

5.2 Endurance test (9) shall be carried out after the operation test (10).

6. CLASSIFICATION

6.1 The relevant provisions of 6 of IS 302 (Part 2/Sec 14) shall apply.

7. MARKING

7.1 The relevant provisions of 7 of IS 302 (Part 2/Sec 14) shall apply in addition to those indicated in 7.2 to 7.5.

7.2 Each appliance shall be accompanied by an instruction booklet containing the following information:

- a) Precautions

- 1) While positioning of the appliance, and
 - 2) Before switching on the appliance.
- b) Warning
- 1) About the parts of the appliance which shall not be brought into contact with liquids;
 - 2) About keeping away from moving parts; and
 - 3) About running the appliance empty, if necessary.
- c) Instructions
- 1) For assembling and dismantling the bowl for cleaning and servicing;
 - 2) Type of supply to which the appliance may be connected and instructions for electrical connections;
 - 3) Don't insert finger or any other object when the machine is in operation or connected with supply mains.
 - 4) Instructions to the effect that after every use of food-mixer, pour warm water into the bowl to remove left over material, especially sticky substances, so that the cutter will rotate freely during the subsequent use; and
 - 5) The manufacturer may include instructions stating that the machine may be overhauled at least once in a year so that its useful life is increased.
- d) Directions to switch off when the motor stalls or smoke emanates from the appliance, and.
- e) Guide for operation, giving maximum quantity per loading and in the case of multi-speed appliances speed/control positions suitable for various operations.

7.3 If the appliance is delivered with alternative accessories, the rated input shall correspond to the most unfavorable accessories, and speed setting.

7.4 Marking of Control Switch – The 'on' or 'off' or both positions of the control switch shall be clearly marked. If any speed control device is provided, the various positions shall be clearly and indelibly marked.

7.5 Accessories sold separately by the appliance manufacturer shall be accompanied by an instructions sheet giving all relevant information unless it is included in the manufacturer's instructions for the appliance.

7.6 BIS Certification Marking

Electric food-mixers (liquidizers and grinders) and centrifugal juicers may also be marked with the Standard Mark.

7.6.1 The use of the standard mark is governed by the provisions of Bureau of Indian Standards Act, 2016 and the Rules and Regulations made thereunder. The details of the conditions under which the licence for use of the standard mark may be granted to manufacturers or producers may be obtained from the Bureau of Indian Standards.

8 SAFETY REQUIREMENTS

The relevant provisions of **clauses 8 to 32** of IS 302 (Part 2/Sec 14) shall apply. However, for tests of clause 8,20,22 and 24 shall be carried out in accordance with the procedure given in **Annexure B**.

9. ENDURANCE FOR MOTOR AND BASE ASSEMBLY

9.1 The Food mixer/Juicer unit (excluding jars) is operated at rated input. To obtain rated input, food mixers/juicer unit shall be operated with the generator load which can provide constant loading consistently. Detail test set up is given in **Annexure C** of this standard.

The food mixer/Juicer unit is operated for 24 ON hours at rated input at 1.06 times the rated voltage in cycles of ON and OFF periods and then for 24 ON hours at rated input at 0.94 times the rated voltage in cycles of ON and OFF periods.

- a) Food Mixers for short-time operation having rated 'ON' time less than 5 minutes as declared by the manufacturer. The operation being carried out 6 times, the period of operation is 3 min ON and 2 min OFF then adequate rest time to cool down the appliances to room temperature which is not more than 60 min.
- b) Food Mixers for short operation having rated 'ON' time more than 5 minutes as declared by manufacturer, The Operation being carried out 6 times, the period of operation is 5 min ON and 2 min OFF then adequate rest time to cool down the appliances to room temperature which is not more than 60 min.
- c) For Food Mixers for short time operation having rated 'ON' time of more than 30 min as declared by manufacturer. The Operation being carried out with number of times calculated by dividing declared rated ON time by 5 (rounded off to nearest integer). The period of operation is 5 min ON and 2 min OFF then adequate rest time to cool down the appliances to room temperature which is not more than 60 min.
- d) For Food Mixers for continuous operation, The Operation being carried out is at least 10 times or until steady conditions are established, whichever is more. The period of operation is 5 min ON and 2 min OFF then adequate rest time to cool down the appliances to room temperature which is not more than 60 min.

The addition of ON time of all cycles shall be equal to the required 48 ON hours.

NOTE 1— The adequate rest period shall be the period enough to bring the appliance to the room temperature. Forced cooling can be applied during this off period.

Note 2- The Food Mixers tested under the rated input condition, any control like Overload protection (OLP) that limits the rated input loading during the test shall be short-circuited.

Note 3- Food-mixer/juicer which can be operated at different speeds shall be operated at the highest speed setting.

Note 4- Consumable item like coupler are subjected to replace incase of breakage due to fitment in fixture hence excluded from the failure mode.

After this test, the food mixer shall withstand the electric strength test of 16.3 of IS 302-1.

10. OPERATIONAL TESTS

10.1 The food-mixers shall be subjected to such of the following operational tests for which it is declared suitable by the manufacturer with the mixer connected in a circuit with a watt-meter and supplied with maximum rated voltage. The tests with the recipes shall generally be conducted as per the method specified in the instruction's booklet supplied by the manufacturer for the corresponding recipes. However, with respect to tests of grinding coffee, whisking egg whites and idli batter, if the method for making recipes are not given in the instruction booklet tests in 10.2, 10.3 and 10.4 shall be followed. The total time of actual operation of the machine in each test shall be noted and recorded

with a stopwatch or a similar device. When the food-mixer is of intermittent operation type, each maximum period of operation during the test shall be equal to the period marked and each period of rest shall at least be equal to the rest period marked.

10.2 Grinding Coffee (for Machines Which Have a Dry Grinding Arrangement)

Freshly roasted coffee seeds corresponding to the grading 'light roast' of IS 3077 shall be used for this test. The weight of seeds in grams shall be 40 percent of the rated capacity in milliliters of the grinder bowl of the machine under test. The seeds shall be ground for an operational time of 3 min or less and the total time including periods of rest shall not exceed 5 min. If required, the material adhering to the sides and cover may be scrapped and loosened with a spoon, once during the test, when the machine is at rest. At the end of the test, the material shall be removed and weighed. The result of grinding shall be assessed by sieve as per IS 460 (Part 1) successively through the following Indian Standard Sieves: 710,500 and 355 microns

The method of sieving indicated in IS 3077 shall be used. The material retained on each of the first two sieves shall not be more than 20 percent of the weight obtained at the end of the test. The material passing through the third sieve shall not be less than 30 percent of the same weight.

NOTE — It is recommended that coffee seeds of the 'pea bury' variety supplied by the coffee board, are used for this test.

10.3 Whisking Egg Whites (for Machines that have Whisking Egg Arrangement)

Fresh eggs shall be used for this test. The whites shall be carefully separated and used at once. The weight in grams of the egg whites used in a test shall be 20 percent of the rated capacity of the liquidizer bowl in milliliters. The egg whites shall be initially at room temperature. They shall be whisked in the machine to produce a stiff froth. The actual operational time required shall not exceed 3 min, and the total time including periods of rest shall not exceed 5 min. The result shall be considered satisfactory if the bowl is inverted for 5 s and the material remains in the bowl.

10.4 IDLI Batter

The general procedure for preparing the *IDLI* batter is to take decuticled black gram (*urad dal*) and parboiled rice in the proportions 1: 2 by mass, soak them separately in the required quantity of water for 12 h and then grind them separately before mixing 'them together. The black gram is ground to a smooth and frothy consistency, and the rice is ground to fine semolina in water.

For the purpose of this test, the solid ingredients shall be taken in the weights specified below for different sizes of liquidizer bowls and soaked in the quantity of water shown against each mass of solid. The soaked solid with the unabsorbed water shall then be transferred to the bowl and ground. Excess water to the extent of 20 percent can be added as and when needed for achieving smooth grinding results during grinding.

Rated Capacity of Bowl	Black Gram		Parboiled Rice	
	Solids G	Water ml	Solids G	Water ml
0.5	100	225	100	113
1.0	200	450	200	225
1.5	300	675	300	338

NOTE — For other capacities the quantity of solid ingredients shall be fixed by interpolation.

The maximum operational time for grinding each ingredient shall be 6 min with a period of rest as recommended by the manufacturer.

NOTE — To prepare a batter with the black gram and rice in the proportions 1:2 requires two batches of rice to be ground for every batch of black gram. For the present test one batch of each will suffice as the results of grinding are assessed without completing the mixture and cooking it in the form of *IDLIS*.

The results of grinding the black gram are assessed by working the mixture between the thumb and fingers. The mixture shall be smooth and frothy and no lumps shall be detected.

The results of grinding the rice shall be assessed by diluting the ground mixture with a sufficient quantity of clean Water and sieving it successively through the following Indian Standard Sieves: 1.40 mm, 1.00 mm and 500 microns:

The ground material from the bowl is recovered as fully as possible by rinsing it with water, the same water being then used for dilution. After sieving, the water from the material retained by each sieve shall be allowed to drain away for 5 min and the material shall then be recovered and weighed.

The grinding shall be considered satisfactory if not more than 10 percent of the mass of rice originally taken is retained by the 1.40 mm sieve; not more than 15 percent by the 1 mm sieve and not more than 70 percent by the 0.5mm sieve.

10.5 Operational Tests for Juicers

10.5.1 A suitable quantity of washed and cleaned carrots or fresh seasonal fruits shall be taken and soaked in water at room temperature for 24 h. The top and tail shall be cut off. These shall be cut into smaller pieces approximately 20 mm thick and weighed.

The juicer shall be operated at the rated voltage as per the operating instructions given by the manufacturer. For juicers designed for batch operation, a quantity of about 350 g of carrots/ fresh seasonal fruits shall be used for each cycle of operation. The juicer shall be operated for 5 cycles of operation. The juicers designed for continuous operation shall be operated for 5 min or the rated operating time of the juicer whichever is less.

In either case, the juice extracted shall be filtered through a 0.25 mm sieve and the total quantity of juice weighed. The total time for juice extraction which is measured from the moments, the feeding of fruits is started till the juice stops coming out and excludes the time required for

dismantling, cleaning and reassembly is noted. In the case of juicers designed for batch operation, this time is the sum of time for juice extraction for five cycles for which the juicer is to be operated. The following results shall then be calculated:

- a) The rate of juice extraction, in g/min (B/C); and
- b) The amount of juice extracted expressed as a percentage of the carrots taken B/A

Where,

A = the total quantity of carrots taken, in g;

B = the total amount of juice extracted, in g; and

C = the total time taken for juice extraction, in minutes.

The juice pouring out of the vent provided for the purpose should have an even flow. The rate of juice extraction shall not be less than 50 percent.

10.5.2 The juicer shall be dismantled, cleaned and inspected. There shall be no spillage/leakage from the centrifugal mesh to such parts of the juicer which do not form the flow path of the extracted juice.'

11 TEMPERATURE WITHSTAND TEST FOR BOWL

Boiling water shall be poured into the bowl at room temperature rapidly to fill it to its capacity.

11.1 After the test the bowl shall be emptied and brought back to room temperature. The test shall be repeated five times. The bowl shall not show any sign of cracks and deformation and shall properly fit into the holder after the test.

NOTE — This test is not applicable in case the bowl is made of metal.

12 TEST FOR CONTROLS

12.1 Test for Switches

Controlling switches shall be capable of breaking the stalled motor current at the maximum rated voltage six times without failure. This test is carried out on d.c. unless the machine is marked 'a.c. only'. (For the purpose of these tests the rated capacity shall be taken as equivalent to the rated input of the machine.)

13 STRENGTH OF ASSEMBLY

The bowl shall be assembled and mounted on the motor housing under the following controlled conditions six times. There shall be no chipping, cracking, or visible denting on the mounting surfaces:

- a) Press fit joints using a force of 25 kgf, and
- b) Screwed on joints using a screwing couple of 25 kgf. cm.

14 SCHEDULE OF TESTS

14.1 Type Tests

The tests specified in Table 1 shall constitute the type tests and shall be carried out on one sample of food-mixer/juicer selected preferably at random from a regular production lot.

14.1.1 Criteria of Acceptance

The sample shall successfully pass all the type tests for proving conformity with the requirements of this specification. If any of the samples should fail in any of the type tests, the testing authority, at its discretion, may call for fresh samples not exceeding twice the original number and subject them to all the tests or the test(s) in which the failure(s) occurred. No failure shall be permitted in the repeat test(s).

Table 1 Type Tests
(Clause 14.1)

SI No.	Tests	Clause Reference
(1)	(2)	(3)
i.	Safety requirements	8
ii.	Endurance for motor and base assembly	9
iii.	Operational tests	10
iv.	Temperature withstand test for bowl	11
v.	Test for controls	12
vi.	Strength of assembly	13

14.2 Acceptance Test

Table 2 shall constitute acceptance tests.

Table 2 Acceptance Tests
(Clause 14.2)

SI No.	Tests	Clause Reference-
(1)	(2)	(3)
i)	Protection against access to live parts	8 of IS302-2-14
ii)	Power input and current	10 of IS302-2-14
iii)	Leakage current and electric strength at operating temperature	13 of IS302-2-14
iv)	Moisture resistance	15 of IS302-2-14
v)	Leakage current and electric strength	16 of IS302-2-14

vi)	Provision for earthing	27 of IS302-2-14
vii)	Operational tests	10
viii)	Temperature withstand test for bowl	11

14.3 Routine Tests

Table 3 shall constitute routine tests:

Table 3 Routine Tests (Clause 14.3)		
SI No.	Tests	Clause Reference
(1)	(2)	(3)
i)	Protection against access to live parts	8 of IS302-2-14
ii)	Leakage current and electric strength at operating temperature	13 of IS302-2-14
iii)	Provision for earthing	27 of IS302-2-14

NOTE — A simple running test to verify satisfactory functioning shall be conducted on every food-mixer/juicer.

ANNEXURE A – Heating Test

The test will be done by the following method:

The test procedure shall be followed by either of the method given in accordance with Figure 1 or Figure 2 of Annexure B.

The appliance shall be operated using generator load as shown in Figure 1 or Figure 2 or any other means, which can continuously provide consistent load.

Temperature rises of windings are determined by the resistance method unless the windings are non-uniform or if it is difficult to make the necessary connections, in which case the temperature rise is determined by means of thermocouples.

The temperature rise of a winding is calculated from the formula:

$$\Delta t = \frac{R_2 - R_1}{R_1} (k + t_1) - (t_2 - t_1)$$

where

Δt	temperature rise of the winding;
R_1	resistance at the beginning of the test;
R_2	resistance at the end of the test;
k	234.5 for copper windings and 225 for aluminium windings;
t_1	room temperature at the beginning of the test; and
t_2	room temperature at the end of the test.

At the beginning of the test, the windings are to be at room temperature. It is recommended that the resistance of windings at the end of the test be determined by taking resistance measurements as soon as possible after switching off and then at short intervals so that a curve of resistance against time can be plotted for ascertaining the resistance at the instant of switching off.

Follow the instructions for testing procedure.

- a) Adjust the generator load setup in accordance with the appliance (for eg. mixer grinder) model.
- b) A generator with variable resistive load is placed on the appliance.
- c) The appliance shall be operated under specified (generator) load and supplied with the most unfavorable voltage between 0.94 times and 1.06 times the rated voltage
- d) The appliance shall be operated at rated power input with the specified (generator) load or any other means, which can provide constant load consistently.

The appliance will be operated as follows:

- a) Food mixers for short-time operation, having rated 'ON' time less than 5 minutes or as declared by the manufacturer. The operation being carried out 6 times, the period of operation is 3 min ON and 2 min OFF.
- b) Food mixers for short-time operation having rated 'ON' time of more than 5 minutes but not more than 30 min or as declared by the manufacturer. The operation being carried out 6 times, the period of operation is 5 min ON and 2 min OFF.
- c) Food mixers for short-time operation having rated 'ON' time of more than 30 min or as declared by the manufacturer. The operation is carried out with a number of times calculated by dividing the declared rated ON time by 5 (rounded off to the nearest integer). The period of operation is 5 min ON and 2 min OFF.
- d) For appliances for continuous operation, The Operation being carried out until steady conditions are established, the period of operation is 5 min ON and 2 min OFF.

Appliances that can be operated at different speeds shall be operated at the highest speed.

During the test, the temperature rises are monitored continuously and shall not exceed the values shown in Table 3 in accordance with *Clause 11* of IS 302-1.

ANNEXURE – B

B.1 Heating

Test under clause 11 of IS 302-2-14 to be checked as per methodology given in **Annexure – A**

B.2 Stability and mechanical hazards:

The relevant provisions of 20 of IS 302 (Part 2/Sec 14) shall apply except that the test probe test specified at 20.2 of IS 302 (Part 2/Sec 14) is carried out with the lid placed on the bowl and the bowl placed on the pedestal.

B.3 Construction:

The relevant provisions of 22 of IS 302 (Part 2/14) shall apply in addition to those specified in **B.3.1** to **B.3.9**.

B.3.1 The machine shall be compact, self-contained, and of rigid construction.

B.3.2 All parts required to be cleaned and kept in a hygienic condition shall be readily accessible without the use of special tools.

B.3.3 All castings and other materials required to be handled shall be smooth, round-edged, and free from blow holes, pits, foreign matter, and surface imperfections.

B.3.4 Machined and formed parts shall be made to ensure complete interchangeability and parts subject to wear shall easily replaceable.

B.3.5 In the case of liquidizers, a lid shall be provided to retain food during preparation. When jars are provided with a lid, the lid shall be held firmly either by hand or other adequate means while operating. A breather incorporated in the lid shall also be provided.

Note- For the lid placement on the Jars, suitable caution is to be provided by the manufacturer on the Lid and in the instruction booklet/ manual.

B.3.6 In the case of grinder with the bowl of the open type, a lid shall be provided.

B.3.7 The design shall ensure that no accidental bodily contact is made with the cutters or blades during the normal operation of the machine.

B.3.8 The machine shall be designed to ensure that lubricants do not contaminate the food and that food is prevented from reaching the moving parts of the machine except blades and cutters.

B.3.9 The cutters and such other exposed parts of the machine in contact with food shall be of such material as to prevent fouling of foodstuffs and to resist corrosion and rusting. Stainless steel is one such material that can meet the above requirements.

B.4 Components:

The relevant provisions of **24** of IS 302 (Part 2/14) shall apply in addition to those specified in **B.4.1** to **B.4.6**

B.4.1 Body or the Motor Housing

It shall be made of cast iron, cast aluminum, sheet metal, high-impact thermosetting plastics or thermoplastics like acrylonitrile-butadiene-styrene (ABS) and polypropylene, etc. of adequate strength and shall provide stability to the machine and shall also withstand all stresses encountered during normal use. Openings for ventilation of the motor shall be properly screened to ensure that no water gets into the appliance due to spillage.

B.4.2 Mechanical Power Coupling

The coupling shall be flexible and shall be fabricated out of materials that shall not deteriorate with the extended normal use of 48 hr as indicated in **9**. It shall be able to withstand shock and vibrations of power transmission and speed changes (in the case of the multispeed machine). It shall be easily replaceable.

B.4.3 Bearings

The bearings may be of the sleeve or ball type. They shall be permanently lubricated. The bearings shall have a life of at least 48 hr as indicated in clause **9**.

B.4.4 Bowl

The container or the bowl in which food is converted into slurry, pulp, or other liquids or in which dry food is pulverized shall be made out of materials that are neutral to food acids and salts, which do not deteriorate with age, and which can withstand temperatures up to 100°C without change in their

physical, mechanical and chemical structures, and properties. Preferred materials are clear or colored milky glass, clear or colored high-impact thermosetting plastic, or stainless steel. The bowl shall be easily removable from the machine and shall be free from pits, cracks, and crevices. It shall be smooth and shall not have corners and niches, to facilitate cleaning. The fixing arrangement of the bowl shall be adequately strong to stand repeated operations. It may be fitted with handling grips.

B.4.5 Assembly

The bowl shall have arrangements for its stable and easy mounting on the motor housing without the use of any tools. Accurate guides shall be provided to ensure correct mounting. Where the bowl is detachable from the base plate, a proper gasket shall be provided, and also mechanical seal for leakproof assembly shall be provided. It shall be possible to remove the bowl with the base plate if provided separately as one assembly for the purposes of emptying the contents.

B.4.6 Blades of Cutters

The material of the blades of cutters shall be stainless steel SS 304 or higher-grade stainless-Steel material.

Annexure C – Generator load setup

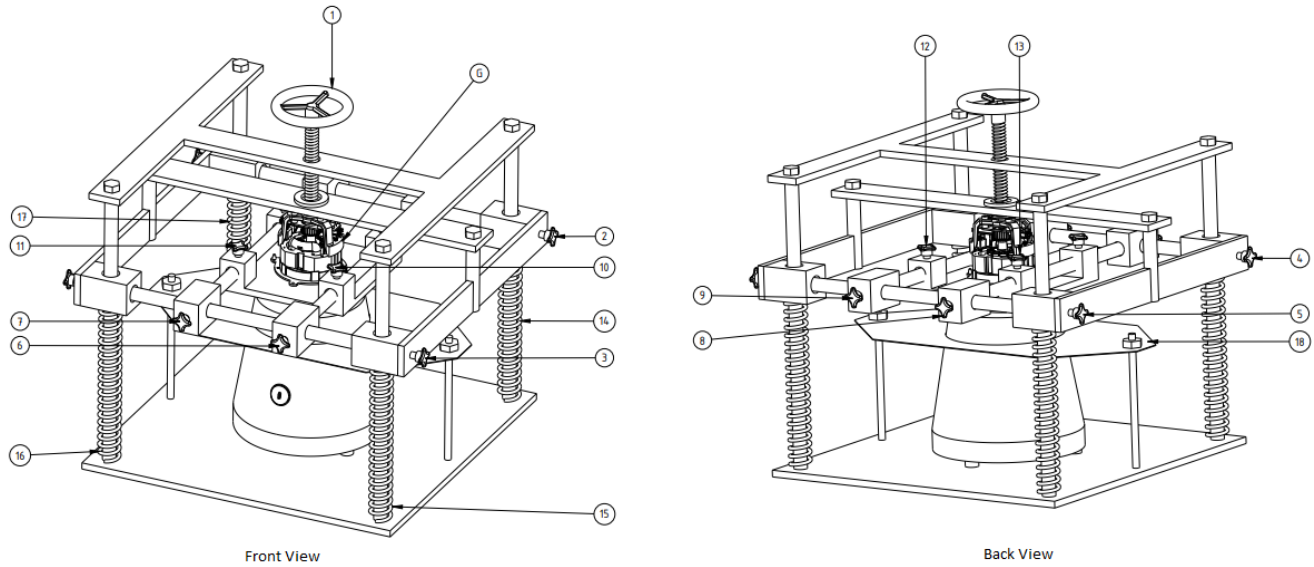

Figure-1, Motor unit with generator load with a fixture.

Note: The fixture is designed such that the variable generator load is attached on the appliance. The movement (x-axis, y-axis and z-axis) of the fixture is adjustable in accordance with the appliance. The bulbs can be used to adjust/maintain the load.

OR

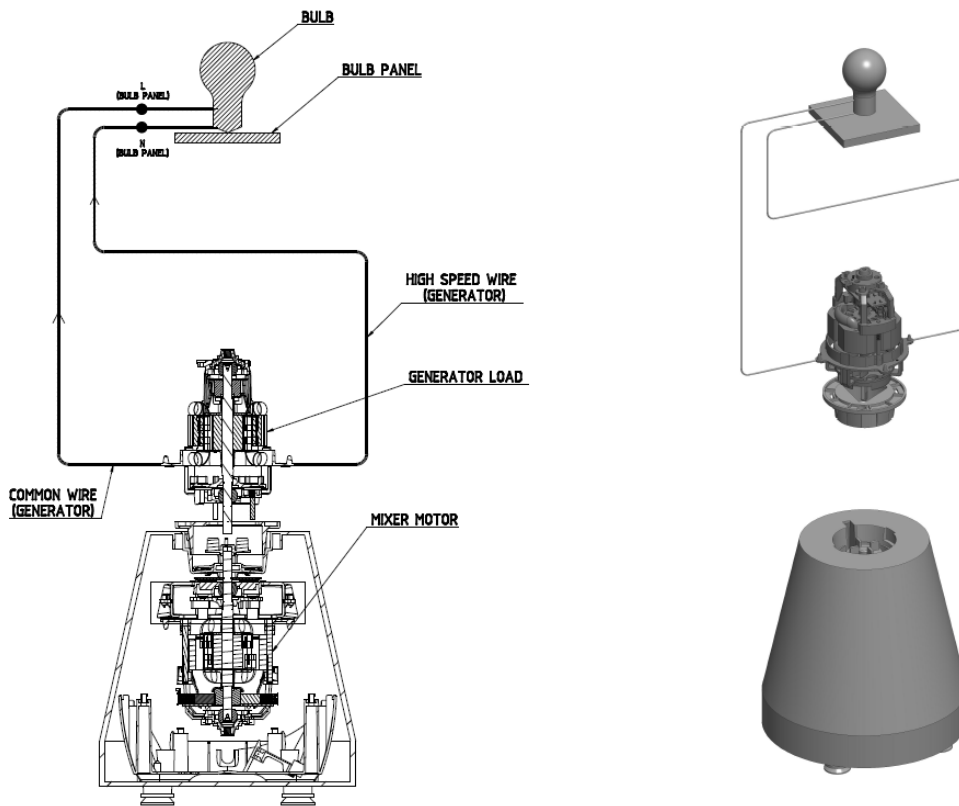

Figure-2, Motor unit with generator load without a fixture.

Note: A suitable jar collar (as per appliance model) is mounted with the mixer motor top bracket to make the generator, and lock the generator on the top of the appliance unit. The bulbs can be used to adjust/maintain the load.

Procedure of Fixing of appliances on the fixture

1. Prepare a fixture as shown in figure 1.
2. The fixture unit consist of a base of metal surface, stand consist of adjuster (1), knob adjusters (2 to 13), springs (14 to 17) and clamp (18).
3. The generator load (G) is attached at the top centre of fixture as shown in figure 1.
4. The clamp (18) is used to fix the testing appliance (eg, mixer grinder).
5. The adjuster (1) is used to adjust the height (up and down movement) of the generator load (G).
6. The knob adjusters (6, 7, 8, 9) are used to adjust the Left and Right movement of the generator load (G).
7. The knob adjusters (10, 11, 12, 13) are used to adjust the To and Fro movement of the generator load (G).
8. The load generator (G) is attached at the top of the testing appliance and fixed with coupler-to-coupler engagement (60% to 80% engagement).
9. The knob adjusters (2, 3, 4, 5) are used to stable the whole setup after all the adjustments/movements are fixed.
10. To create load, the common wire and high speed wire of generator (G) is connected with load bulbs.
11. The load bulbs are connected in parallel assembly and the load can be varied as per the requirement.

Note: The load can be created with resistive elements other than bulbs.

Procedure of Fixing of appliances without fixture

1. Prepare a setup as shown in figure 2.
2. The generator load (G) consist of a motor with replaceable collar.
3. The collar is attached to the bottom of the generator load (G) with the help of screws and bolts.
4. The spacers are used to adjust the height of the collar with respect to the appliance.
5. The generator load (G) is mounted on the appliance for testing.
6. To create load, the common wire and high-speed wire of generator (G) is connected with load bulbs.
7. The load bulbs are connected in parallel assembly and the load can be varied as per the requirement.

Note: The load can be created with resistive elements other than bulbs.