

BUREAU OF INDIAN STANDARDS**DRAFT FOR COMMENTS ONLY**

(Not to be reproduced without the permission of BIS or used as an Indian Standard)

भारतीय मानक मसौदा

कृषि ट्रैक्टरों की हाइड्रोलिक शक्ति और उठाने की क्षमता – परीक्षण विधि

[आइ एस 12224 का पहला पुनरीक्षण]

Draft Indian Standard

**HYDRAULIC POWER AND LIFTING CAPACITY OF AGRICULTURAL TRACTORS
— TEST METHOD**

(First Revision of IS 12224)

ICS 65.060.10

Agricultural Machinery and Equipment
Sectional Committee, FAD 11

Last date for Comments: **13 May 2024**

FOREWORD

(Formal clause will be added later)

The hydraulic lift of tractor is an important functional component through which the power is delivered to the three-point linkage system. This standard covering the test method for hydraulic power and lifting capacity was published in 1987 deriving assistance from the following:

- a) Procedure followed at Central Farm Machinery Training and Testing Institute (Ministry of Agriculture), Budni;
- b) ISO 789-2 : 1983 Agricultural tractor — Test procedures — Part 2: Hydraulic power and lifting capacity; and
- c) OECD standard codes for the official testing of agricultural tractors performance, 1986.

The first revision of the standard has been undertaken to incorporate the two amendments issued to the earlier version, necessary editorial corrections and to bring it in the latest style and format of Indian Standards. References to Indian Standards wherever applicable have also been updated.

In reporting the results of a test or analysis made in accordance with this standard, if the final value, observed or calculated, is to be rounded off, it shall be done in accordance with IS 2 : 2022 'Rules for rounding off numerical values (*second revision*)'.

*Draft Indian Standard***HYDRAULIC POWER AND LIFTING CAPACITY OF AGRICULTURAL TRACTORS
— TEST METHOD***(First Revision of IS 12224)***1 SCOPE**

This standard specifies test procedures for determining following hydraulic performance characteristics of agricultural tractors:

- a) The maximum static vertical force which can be exerted by the hydraulic lift at the lower hitch points and at a point 610 mm rear to lower hitch points throughout its power range;
- b) The maximum static vertical force which can be exerted by the hydraulic lift, at a point 610 mm to the rear of the hitch points on a frame attached to the three-point linkage, throughout its full range of movement;
- c) The hydraulic pump and relief valve performance; and
- d) The ability of the lifting system to maintain the load in the lifted position without hydraulic power.

2 REFERENCES

The standards given below contain provisions which through reference in this text, constitute provisions of this standard. At the time of publication, the editions indicated were valid. All standards are subject to revision and parties to agreements based on this standard are encouraged to investigate the possibility of applying the most recent editions of the standards indicated below:

<i>IS No.</i>	<i>Title</i>
IS 5994 : 2022	Agricultural tractors — Test code (<i>fourth revision</i>)
IS 17231 : 2019/ISO 730 : 2009	Agricultural wheeled tractors —Rear-mounted three-point linkage — Categories 1N, 1, 2N, 2, 3N, 3, 4N and 4
IS 9466 : 2020	Viscosity classification for industrial liquid lubricants (<i>first revision</i>)

3 TEST CONDITIONS

3.1 The tractor shall be run-in prior to the test, if specified by the manufacturer/applicant.

3.2 The type and viscosity of the hydraulic fluid shall conform to the specifications supplied by the tractor manufacturer/applicant. If it conforms to the relevant Indian Standard (*see* IS 9466), this shall be stated.

3.3 The throttle or governor control lever shall be adjusted to maintain the rated engine speed except where otherwise specified by the manufacturer/applicant.

3.4 At the start of each test, the temperature of the hydraulic fluid in the tank shall be measured and shall be 65 ± 5 °C. If this cannot be achieved, owing to the presence of an oil cooler for example, the temperature measured during the test shall be stated in the test report.

3.5 A pressure gauge shall be fitted externally in the hydraulic circuit of the tractor as specified by the manufacturer/applicant.

3.6 The test set up and method for flow versus pressure determination of pump as given in Annex A should be followed.

3.7 Other general guidelines and accuracy of measurement as given in IS 5994 shall be followed.

4 HYDRAULIC LIFT CAPACITY TEST

4.1 General

4.1.1 The unballasted tractor shall be supported and secured in horizontal position at the rear wheel axis so that the tyres are not deflected by the reactive forces of the power lift.

4.1.2 The linkage shall be adjusted as appropriate for the tests with or without the coupled frame, to achieve typical and repeatable arrangements as follows:

- a) The linkage shall be adjusted in such a way as to achieve the power range required in IS 17231 and a height of the lower hitch points, in the lowered position, of 200 mm for category 1 and 2 and 230 mm for category 3 above ground level. The height shall be obtained with the loaded radius of tyre with inflation pressure recommended for field operation. For those tractors which do not achieve the standard power range, the lifting force shall be measured at the maximum achievable power range.

NOTE — If the tractor cannot achieve the specified power range and lower hitch point height, the fact shall be stated in the test report.

- b) The upper link shall be adjusted to the length necessary to bring the mast of frame vertical when the lower links are horizontal.
- c) Where more than one upper or lower link point is available on the tractor, the points used shall be those specified by the manufacturer/applicant and shall be included in the test report.
- d) Where there is more than one-point attachment to connect the lift rod to the lower links, the connection points used shall be those specified by the manufacturer/applicant and shall be included in the test report.
- e) These initial adjustments, as far as possible, shall cause the mast to rotate through a minimum of 10° over the full range of lift. If this is not possible, the fact shall be stated in the test report.

4.2 Static Lift at Lower Hitch Points

4.2.1 An external vertical downward force shall be applied to a horizontal bar connecting the hitch points. This force, which shall be capable of being measured, shall lie in the central longitudinal plane of the tractor, and shall be maintained vertical throughout the lift range.

NOTE — Care should be taken to avoid torsional components in this force. This can affect the accuracy of measurements.

4.2.2 The lifting force available and the corresponding pressure of the hydraulic fluid shall be measured at a minimum of six points approximately equally spaced throughout the range of movement of the lift. At each point, the force shall be the maximum which can be exerted against a static load. Additionally, the range of movement shall be measured.

4.2.3 The minimum of lifting force shall be corrected to the pressure equivalent to 90 percent of the minimum of relief valve pressure setting specified by the manufacturer. The corrected value shall constitute the maximum vertical force which can be supported by the hydraulic lift throughout its full range of movement.

4.3 Static Lift on Coupled Frame

4.3.1 A frame having the following characteristics shall be attached to the three-point linkage:

- a) The mast height and the distance from the hitch points to the centre line of the tractor shall be appropriate to the linkage category of the tractor as specified in IS 17231. Where more than one category is specified, that chosen for test shall be at the manufacturer's/ applicant's discretion.
- b) The centre of gravity shall be at a point 610 mm to the rear of the hitch points on a line at right angles to the mast upper hitch point and passing through the middle of the line joining the lower hitch points.

4.3.2 An external downward vertical force, which shall be capable of being measured, shall be applied to the frame at the centre of gravity and the weight of the frame shall be added to it to obtain the lifting force.

4.3.3 The lifting force available and the corresponding pressure of the hydraulic fluid shall be measured at a minimum of six points approximately equally spaced throughout the range of the movement of the lift. At each point, the force shall be the maximum which can be exerted against a static load. Additionally, the range of movement shall be measured.

4.3.4 The minimum of lifting force shall be corrected to the pressure equivalent to 90 percent of the minimum of relief valve pressure setting specified by the manufacturer. The corrected value shall constitute the maximum vertical force which can be supported by the hydraulic lift throughout its full range of movement.

4.4 Report

The following shall be reported:

- a) The maximum corrected vertical forces at the hitch points (*see 4.2.3*) and at the centre of gravity of the frame (*see 4.3.4*);
- b) The full range of vertical movement of the respective points of application of force (*see 4.2.2* and *4.3.3*);
- c) The pressure in kPa, corresponding to 90 percent of the minimum of relief valve pressure setting specified by the manufacturer;
- d) The height in millimeters, of the lower hitch point above the ground in its lowermost position and without load;
- e) The angle through which the mast rotates over the full range of lift;
- f) The main linkage dimensions in millimeters including the mast height of the frame, as tested, relative to the centre of the rear wheels (*see Fig. 1*);
- g) The temperature of the hydraulic fluid at the start of each test in degree Celsius; and
- h) The calculated moment around the rear axle, in newton meters, resulting from the maximum corrected external lift force at the frame which can be exerted through the full range of movement.

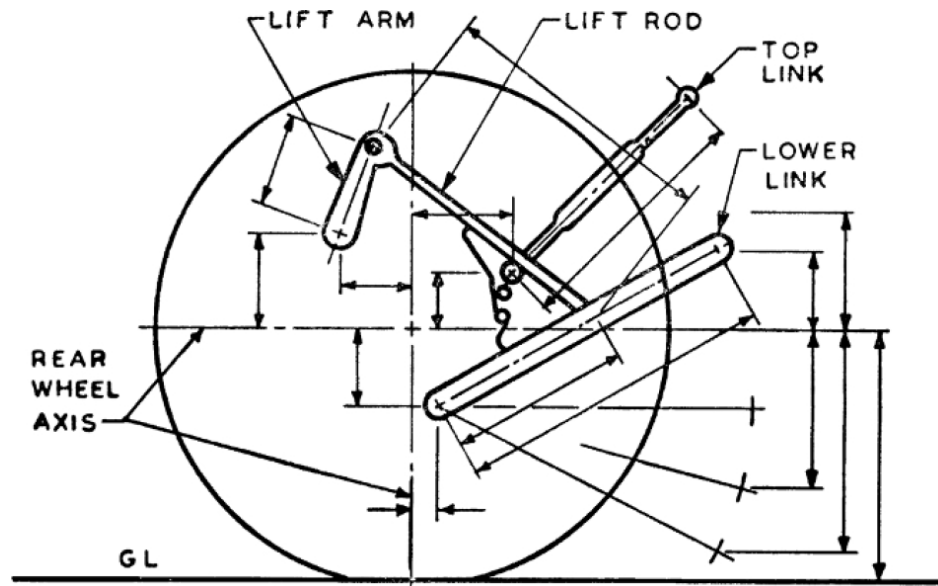

FIG. 1 A TYPICAL ILLUSTRATION OF MAIN LINKAGE DIMENSIONS

5 HYDRAULIC PUMP TEST

5.1 The following measurements shall be reported:

- a) The pressure corresponding to maximum hydraulic power;
- b) The pressure sustained by open relief valve with the pump stalled in case of a closed-centre system with pressure compensated variable delivery pump;
- c) The opening and closing pressures of the unloading valve in the case of a closed-centre system having an accumulator;
- d) The pump delivery rate, in litres per minute, using a designated auxiliary service coupling, as determined with measuring equipment causing negligible pressure drop in the external line;
- e) The maximum hydraulic power, in kilowatts, available at the designated auxiliary service coupling and the corresponding flow rate and pressure.

6 MAINTENANCE OF LIFT OF LOAD

6.1 The tractor shall be secured in accordance with **4.1**.

6.2 A downward vertical force equal to 90 percent of the maximum force as reported under **4.3.4**, which can be exerted throughout the full range of movement, shall be applied to the frame at the centre of gravity.

6.3 With the hydraulic lift in its uppermost position and the control lever in the 'raised' position, the engine shall be stopped and the 'vertical height from ground level' of the point of application of force shall be measured.

6.4 At intervals of 5 min over a period of 30 min, the vertical height shall be re-measured.

6.5 The following measurements shall be reported:

- a) Force applied to the frame,
- b) Decrease in height of the point of application of the force after each 5 min interval and shall be compared with the relevant specification provided by the manufacturer/applicant.
- c) Ambient temperature at the start of measuring, and
- d) Temperature of hydraulic fluid at the start of test.

7 TEST REPORT

A specimen test report is given in Annex B.

ANNEX A
(Clause 3.6)
METHOD FOR DETERMINATION OF FLOW/PRESSURE CHARACTERISTICS OF PUMP

A-1 TEST SET-UP

The set up may be made as per the circuit diagram shown in Fig. 2.

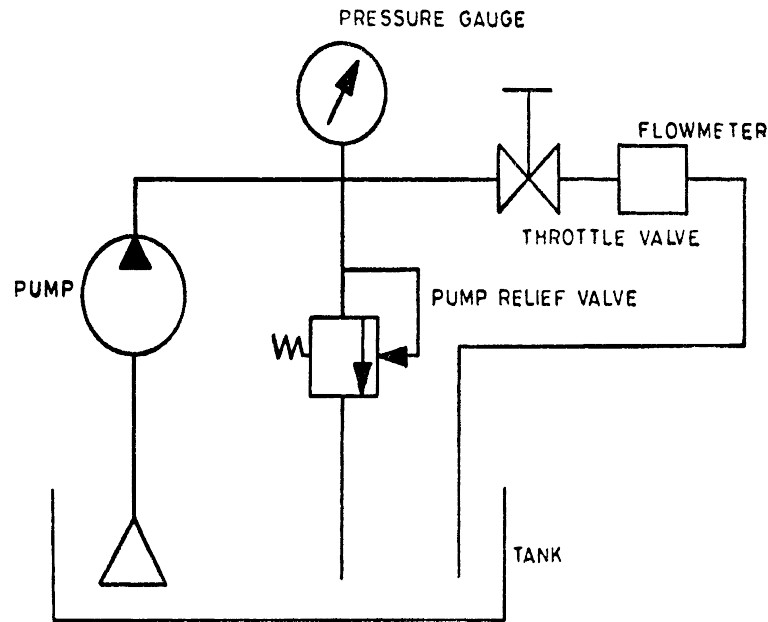

FIG. 2 TEST SET-UP

A-2 TESTS

A-2.1 The test shall be carried out to find out the flow versus pressure characteristics of pump at rated engine speed at least up to the sustained pressure specifications of the manufacturer/ applicant for an open relief valve. The relief valve shall not be in the circuit except where the same is not possible.

A-2.2 The test shall also be carried out to find out the flow versus pressure characteristics of the pump with relief valve combination, at full accelerator setting giving high idling speed in accordance with the manufacturer's specifications, up to the sustained pressure of an open relief valve.

ANNEX B
(Clause 7)
SPECIMEN TEST REPORT

B-1 GENERAL

- a) Tractor manufacturer's name and address
- b) Name of the applicant
- c) Date and location of tests

B-2 DETAILS OF TRACTOR

- a) Model
- b) Serial Number
- c) Mass with tanks full but without ballast or driver, kg
- d) Tyre size
 - i. Front
 - ii. Rear
- e) Wheel base, mm

B-3 DETAILS OF ENGINE

- a) Make
- b) Model
- c) Type
- d) Serial Number
- e) Rated engine speed, rev/min.

B-4 HYDRAULIC FLUID USED IN TESTS

- a) Type
- b) Viscosity
- c) Viscosity index
- d) Type of the hydraulic system

B-5 HYDRAULIC LIFT CAPACITY TEST

a) Test data

Characteristics	Height of lower hitch point above ground in down position, mm	Vertical movement, mm	Maximum force exerted through full range, kN	Pressure, kPa	Moment about rear axle, kN.m	Tilt angle of mast over range of lift, degrees
At Hitch Points						
On the Frame						

b) Temperature of hydraulic fluid, °C

c) Main linkage dimensions (as tested) (*see Fig. 1*)**B.6 HYDRAULIC POWER TEST**

a) Sustained pressure with relief valve open, kPa (Pump stalled — yes/no)

b) Opening pressure of the unloading valve, kPa

c) Closing pressure of the unloading valve, kPa

d) Pump delivery rate at minimum pressure and rated engine/motor speed, l/min

e) Maximum hydraulic power, kW

f) Pressure specified by the manufacturer for an external hydraulic motor, kPa

g) Tapping point

h) Pump delivery rate at stated power, l/min

j) Pressure at maximum power, kPa

k) Temperature of hydraulic fluid, °C

B-7 MAINTENANCE OF LIFT OF LOAD

a) Force applied to frame, kN

b) Ambient temperature at the start of test, °C

c) Temperature of hydraulic fluid at the start of test, °C

d) Test data

Time, min	5	10	15	20	25	30
Drop in height, mm						

e) Data obtained at (d) corresponds with the manufacturer’s specification — yes/no.