

BUREAU OF INDIAN STANDARDS
DRAFT FOR COMMENTS ONLY
(Not to be reproduced without permission of BIS or used as an Indian
Standard)

भारतीय मानक
प्लास्टिक सर्जरी उपकरण - मसनदोइ सीज़र्स
(पहला पनरीक्षण)

Indian Standard
Plastic Surgery Instruments – McIndoe Scissors
(*First Revision*)

ICS 11.040.30

FOREWORD

(Formal Clause will be added later)

This standard was first published in 1967 as 'IS 4281: 1967 Scissors, McIndoe's, for Plastic Surgery'. This first revision has been taken up to align the cross-references to the latest standards.

For the purpose of deciding whether a particular requirement of this standard is complied with, the final value, observed or calculated expressing the result of a test or analysis, shall be rounded off in accordance with IS 2: 2022 'Rules for rounding off numerical values (*Second Revision*)'. The number of significant places retained in the rounded off value should be same as that of the specified value in the standard.

1 SCOPE

This standard covers the requirements for the following McIndoe's scissors for plastic surgery:

- a) Dissecting, triangular blades, blunt points, straight, and curved on flat;
- b) Straight, fine sharp points; and
- c) Curved on flat.

2 REFERENCES

The standard(s) listed below contain provisions which, through reference in this text, constitute provisions of this standard. At the time of publication, the editions indicated were valid. All standards are subject to revision, and parties to agreements based on the standard are encouraged to investigate the possibility of applying the most recent editions of the standards indicated below:

<i>IS No.</i>	<i>Title</i>
IS/ISO 7153-1: 2016	Surgical instruments - Materials: Part 1 metals
IS 4218 (Part 1): 2001	ISO general purpose metric screw threads: Part 1 basic profile - second revision)
IS 3642 (Part 1): 1990	Surgical instruments - Specification: Part 1 non - Cutting, articulated instruments (Second Revision)
IS 7531: 1990	Surgical instruments - Corrosion resistance of stainless-steel surgical instruments - Methods of tests (First Revision)

3 MATERIAL

Scissors and Screws shall be made from stainless steel as specified in IS/ ISO 7153-1.

4 SHAPE AND DIMENSIONS

4.1 Scissors shall conform generally to the shape and dimensions as shown in Fig.1, Fig.2 and Fig. 3.

4.2 Screw

Screw used shall be slotted-cheese head pattern as shown in Fig. 4. The profile of the screw thread shall conform to IS 4218 (Part 1). The thread shall be of such length as to allow sufficient shank for proper bearing surface and to adequately secure component parts of scissors. Screw shall retain position after setting without binding or loosening during use and shall be ground flush with surface of the blades.

4.3 Finger Loop

Finger loops shall be properly shaped and the size shall conform to Size No. 2 as specified in Section 6 of IS 3642 (Part 1).

5 WORKMANSHIP AND FINISH

5.1 Scissors shall be symmetrical and well-balanced.

5.2 The blades along their length and the tips shall coincide and shall not override, when the scissors are fully closed.

5.3 The blades shall open and close without stiffness and shall have a slight cross-over action to give a continuous pinch, and shall have no play at the joint.

5.4 Scissors shall be free from cracks, seams, burrs, flaws and other defects. The surfaces of the scissors shall be finished smooth, passivated and polished bright. The edges shall be even and rounded except for the cutting edge which shall be sharp. The cutting edge shall not have any feather.

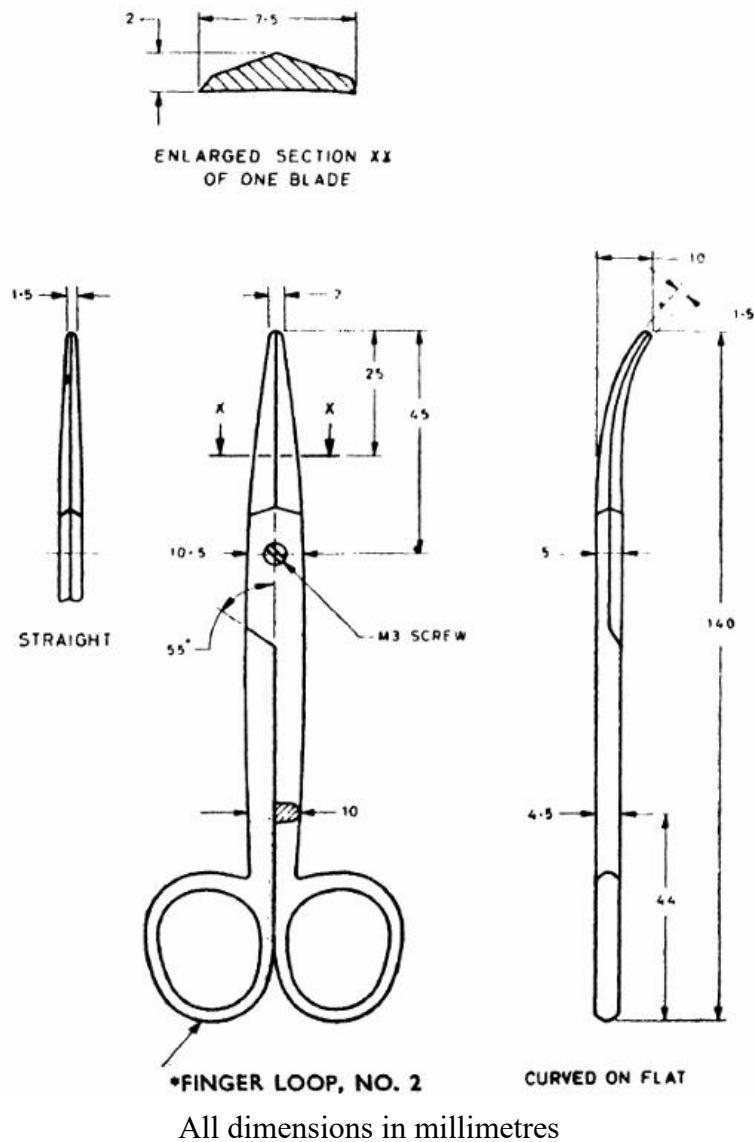
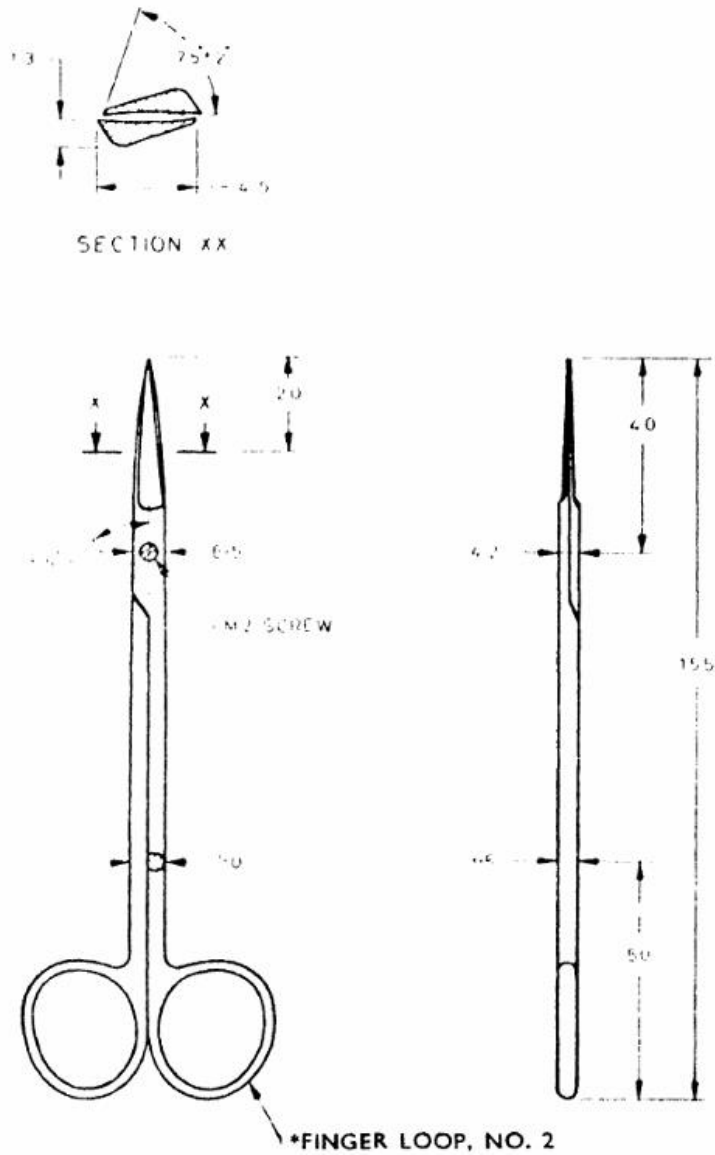
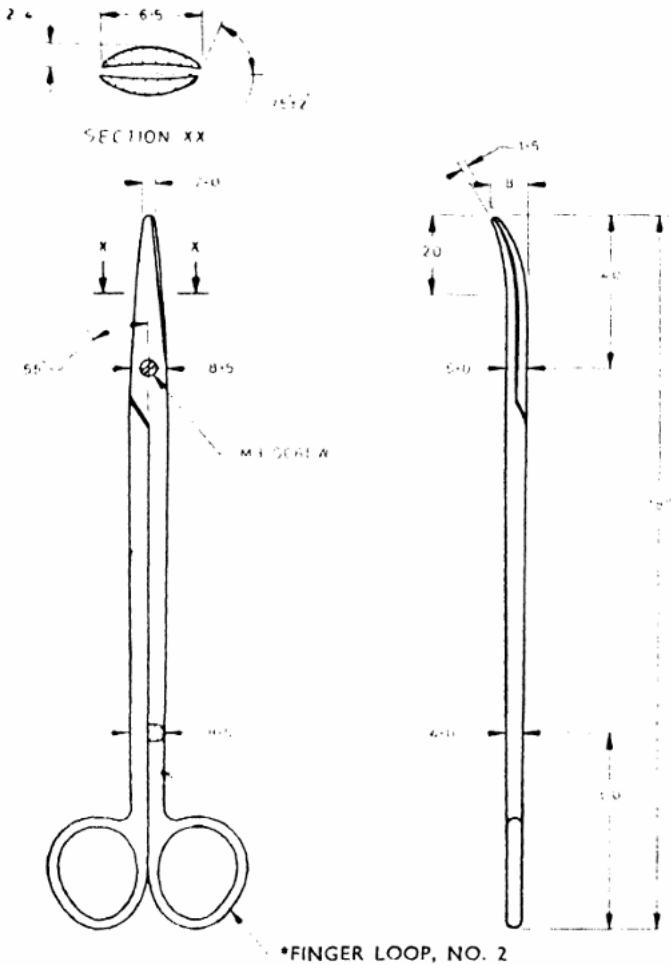

FIG. 1 DISSECTING SCISSORS, BLUNT POINT, TRIANGULAR BLADE, STRAIGHT AND CURVED ON FLAT, McINDOE'S PATTERN



All dimensions in millimetres.

FIG. 2 SCISSORS, FINE SHARP POINT, STRAIGHT, McINDOE'S PATTERN



All dimensions in millimetres.

FIG. 3 SCISSORS, CURVED ON FLAT, McINDOE'S PATTERN

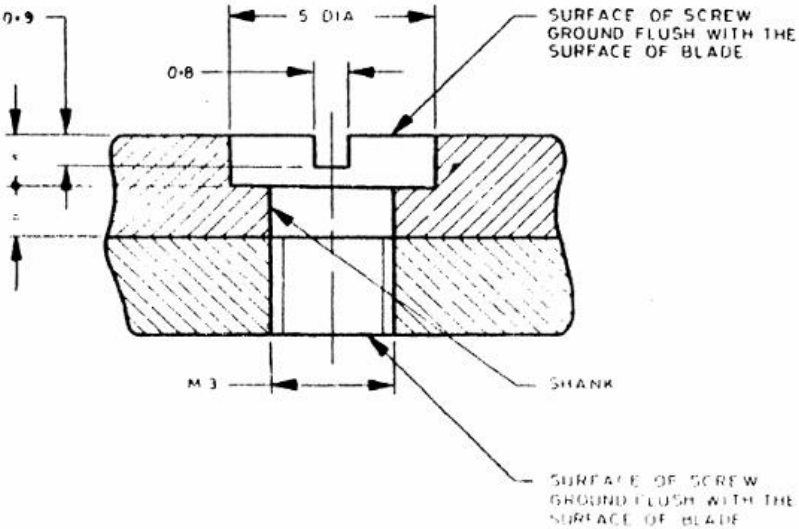

All dimensions in millimetres.

FIG. 4 DETILS OF SCREW ASSEMBLY

6 HARDNESS

Scissors shall be evenly hardened and tempered to 550 to 600 *HV*.

7 TESTS

7.1 Performance

The scissors shall cut wet tissue paper, teased-out cotton wool, fine hairs and frayed lint accurately and cleanly from pinch to tip.

7.2 Hardness

When tested on a hardness testing machine, the scissors shall have a Vicker's diamond pyramid hardness number as specified in Clause 6.

7.3 Flexibility

The flexibility shall be tested as given in 7.3.1 and 7.3.2.

7.3.1 The finger ring of one arm of the scissors shall be fixed at its equator in a vice, with the shank and the blade projecting above the vice. By the application of force at a point 75 mm above the vice, the shank shall be deflected at right angles to the plane of the linger loop to a distance of 10 mm as measured at the tip of the blade. On release of the force, no permanent set shall be observed.

7.3.2 The test shall be repeated on the same arm with the arm fixed in the vice near the joint so that 75 mm of the shank (as measured from the upper surface of the vice jaws to the upper pole of the linger loop) protrudes above the vice. The deflecting force shall be applied at the upper pole of the finger loop and shall act in a plane at right angles to the plane of the linger loop. The shank shall be deflected by 5 mm as measured at the upper pole of the linger loop. On release of force, no permanent set shall be observed.

7.4 Corrosion Resistance

The instrument shall show no sign of corrosion when put to boiling and autoclaving test in accordance with IS 7531.

8 MARKING

8.1 The scissors shall be clearly and indelibly marked with the following:

- a) Manufacturer's name, initials or recognized trade-mark;
- b) The words 'Stainless Steel' or 'SS', and
- c) Batch Number

8.2 BIS Certification Marking

The product(s) conforming to the requirements of this standard may be certified as per the conformity assessment schemes under the provisions of the *Bureau of Indian Standards Act, 2016* and the Rules and Regulations framed thereunder, and the products may be marked with the Standard Mark.

9 PACKING

Each pair of scissors shall be wrapped in moisture-proof polyethylene bag and packed in cartons in a manner that coming into contact with one another is avoided or as agreed to between the purchaser and supplier.