

BUREAU OF INDIAN STANDARDS

DRAFT FOR COMMENTS ONLY

(Not to be reproduced without permission of BIS or used as an Indian Standard)

भारतीय मानक मसौदा
ओस्टियोटोम्स, स्टीले पैटर्न, ओर्थोपेडीक के लिए विशिष्टि
(IS 5583 का पहला पुनरीक्षण)

Draft Indian Standard
Specification for Osteotomes, Stille Pattern, Orthopaedic
(First Revision of IS 5583)

[ICS 11.040.40]

Orthopaedic Instruments, Implants and
Accessories Sectional Committee, MHD 02

Last date for comments: **12 September 2023**

FOREWORD

(Formal clause will be added later)

This standard was originally published in 1970. The first revision of this standard has been brought out to align it with the recent developments and to bring the standard in line with the latest style and format of Indian Standards.

For the purpose of deciding whether a particular requirement of this standard is complied with the final value, observed or calculated, expressing the result of a test or analysis shall be rounded off in accordance with IS 2: 2022 'Rules for rounding off numerical values (*second revision*)'. The number of significant places retained in the rounded off value should be same as that of the specified value in this standard.

1 SCOPE

This standard covers requirement for Stille pattern osteotomes used in orthopaedic surgery.

2 REFERENCES

The standards given below contain provisions which, through reference in this text, constitute provisions of this standard. At the time of publication, the editions indicated were valid. All standards are subject to revision, and parties to agreements based on this standard are encouraged to investigate the possibility of applying the most recent editions of these standards.

<i>IS No.</i>	<i>Title</i>
IS 1570 (Part 5): 1985	Schedules for wrought steels: Part 5 Stainless and heat-resisting steels (<i>second revision</i>)
IS 7531 : 1990	Surgical Instruments – Corrosion resistance of stainless-steel surgical instruments – Methods of tests (<i>first revision</i>)

3 MATERIAL

The material shall be stainless steel conforming to Designation X30Cr13 of IS 1570 (Part 5) or stainless steel of the following composition:

Constituent (1)	Percent (2)
Carbon	0.35 to 0.45
Silicon	0.60 max.
Manganese	0.60 max.
Chromium	12 to 14
Nickel	0.60 max.
Sulphur	0.03 max.
Phosphorus	0.03 max.

4 SHAPE AND DIMENSIONS

4.1 The dimensions shall be as per Fig. 1.

4.2 A deviation of ± 2.5 percent shall be allowed on all dimensions.

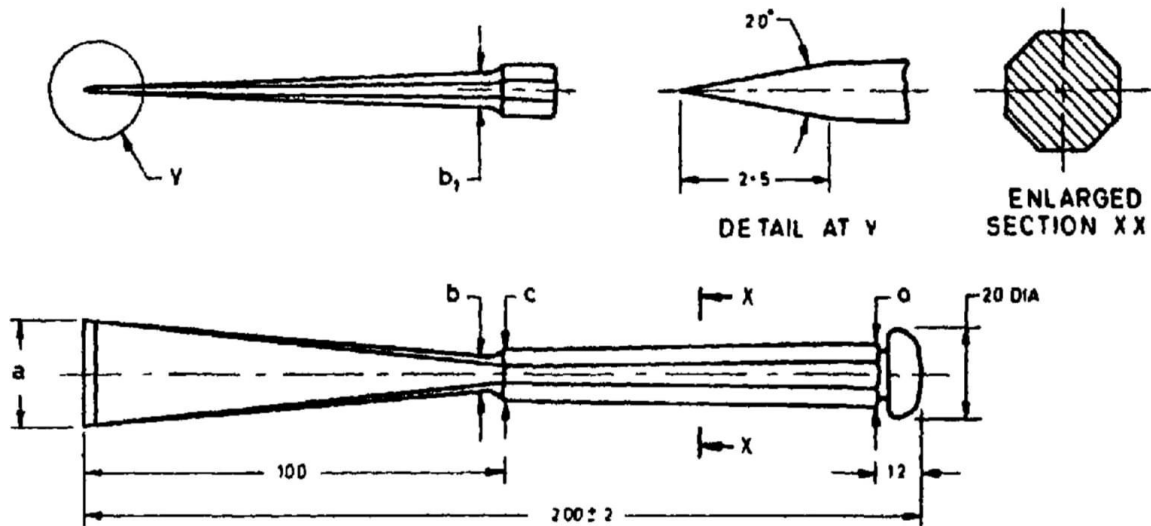

<i>a</i>	<i>b</i>	<i>b₁</i>	<i>c</i>	<i>d</i>
6	5.0	5.0	8	10
10	6.0	6.0	8	12
15	7.0	6.0	10	12
20	8.0	7.0	10	13
25	9.0	7.0	12	13
30	10.0	8.0	12	14

All dimensions in millimetres

FIG 1. OSTEOTOME, STILLE PATTERN

5 REQUIREMENTS

5.1 Workmanship

All the surfaces of osteotomes shall be free from pits, burrs, cracks, and other surface defects. The cutting edge of the instrument shall be properly sharpened and shall be free from burrs, feathers, nicks and waviness. All the other edges shall be even.

5.2 Finish

The instrument shall be suitably passivated and finished smooth and bright.

5.3 Hardness

Evenly hardened and tempered to 500 to 550 *HV*.

5.4 Performance

The osteotomes held firmly and vertically with the cutting edge downward on a piece of hard and dry sheep bone of 10 mm thickness shall be given 20 full blows on the head with a 500-g hammer. On completion of test, head shall not become mushroom shaped. The cutting edge shall not show any sign of damage or loss of cutting efficiency and the shank shall not show any deformation.

5.5 Corrosion Resistance Test

The product shall satisfy the requirements when tested in accordance with IS 7531.

6 MARKING

6.1 The product shall be legibly and indelibly marked with the identification of the source of manufacture; designation of the instrument and letters 'SS' to indicate that the instruments are made of stainless steel.

6.2 BIS Certification Marking

The product(s) conforming to the requirements of this standard may be certified as per the conformity assessment schemes under the provisions of the *Bureau of Indian Standards Act, 2016* and the Rules and Regulations framed thereunder, and the product(s) may be marked with the Standard Mark.

7 PACKING

The packing shall be as agreed to between the purchaser and the supplier.