

BUREAU OF INDIAN STANDARDS

DRAFT FOR COMMENTS ONLY

(Not to be reproduced without permission of BIS or used as an Indian Standard)

भारतीय मानक मसौदा

गर्भाशय साउंड – विशिष्टि

(IS 5829: 1982 का दूसरा पुनरीक्षण)

Draft Indian Standard

UTERINE SOUND – SPECIFICATION

(Second Revision of IS 5829: 1982)

ICS 11.040.30

Obstetric and Gynaecological Instruments
and Appliances Sectional Committee, MHD 03

Last date for comments: 01 May, 2024

FOREWORD

(Formal clause will be added later)

The first revision was published in 1982. The second revision of this standard has been brought out to align the standard with the latest style and format of Indian Standards.

For the purpose of deciding whether a particular requirement of this standard is complied with the final value, observed or calculated, expressing the result of a test or analysis shall be rounded off in accordance with IS 2: 2022 ‘Rules for Rounding Off Numerical Values (*second revision*)’. The number of significant places retained in the rounded off value should be same as that of the specified value in this standard.

1 SCOPE

This standard specifies general requirements for Uterine Sound.

2 REFERENCES

The standards given below contain provisions which, through reference in this text, constitute provisions of this standard. At the time of publication, the editions indicated were valid. All standards are subject to revision, and parties to agreements based on this standard are encouraged to investigate the possibility of applying the most recent editions of these standards.

IS No.	Title
IS 6603: 2001	Stainless steel bars and flats – Specification (<i>first revision</i>)
IS 7531: 1990	Surgical instruments – Corrosion resistance of stainless steel surgical instruments – Methods of tests (<i>first revision</i>)

3 MATERIAL

The material shall be stainless steel conforming to designation X20Cr13 or X30Cr13 of IS 6603.

4 SHAPE AND DIMENSIONS

4.1 The shape & dimensions shall be as shown in Fig. 1 and 2.

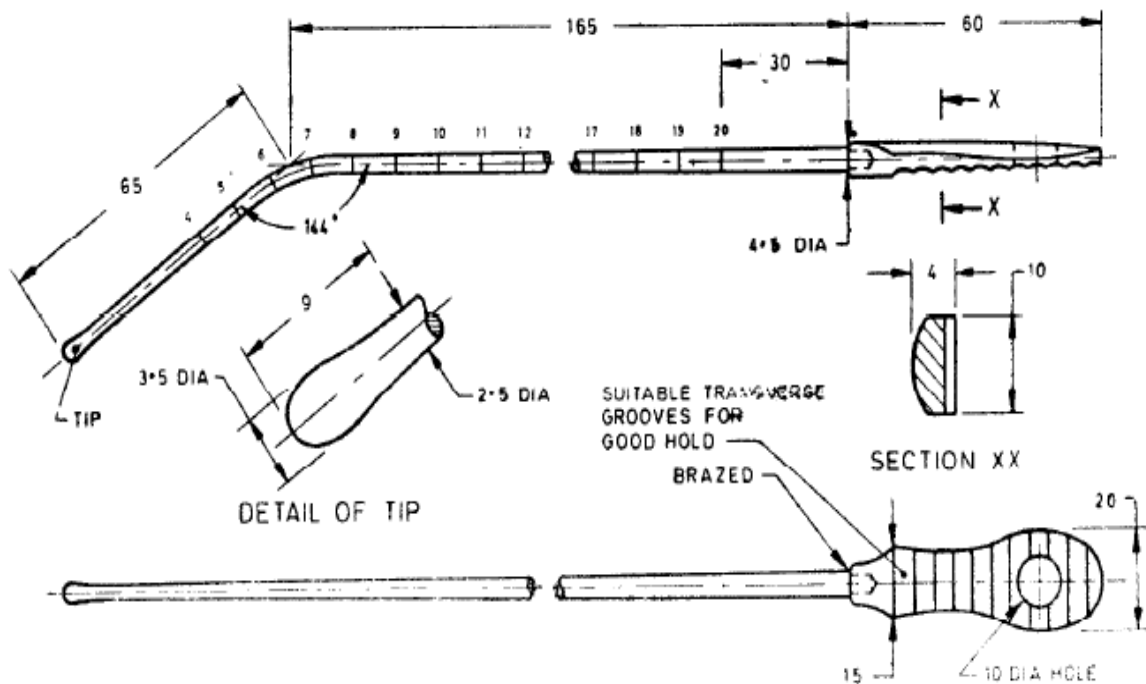

All dimensions in millimetres.
FIG. 1 SOUND, UTERINE

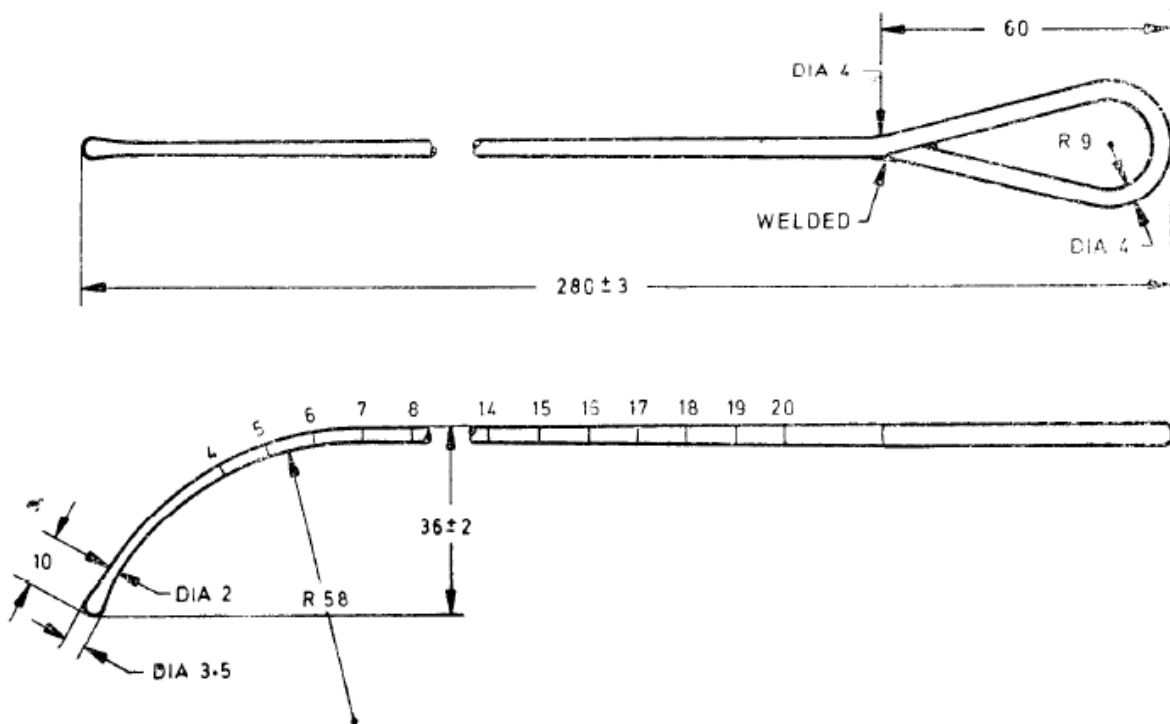

All dimensions in millimetres.

FIG. 2 SOUND, UTERINE

4.2 A deviation of ± 2.5 percent shall be allowed on all dimensions.

5 WORKMANSHIP AND FINISH

5.1 All the surfaces shall be free from burrs, pits, cracks and other defects.

5.2 The tip and the shaft shall be smoothly rounded and shall not be stiff.

5.3 The graduations on the shaft shall be permanently marked at intervals of one centimetre as shown in the figure. These shall not be sharp.

5.4 The instruments shall be polished bright and treated by a suitable passivation process, in 10 percent (v/v) nitric acid solution for not less than 30 min at a temperature of not less than 10°C and not exceeding 60°C . The instruments shall then be rinsed in water and dried in hot air.

5.5 The sound shall be uniformly hardened and tempered to give a hardness of 380 to 420 HV.

6 TESTS (FOR SOLID HANDLE TYPE)

6.1 Grip the shaft firmly in a vice close to its joint to the handle with the handle protruding out. Try to rotate the handle by gripping it between the index finger and the thumb of one hand. Handle shall not move or show damage.

6.2 Grip the shaft firmly in a vice close to angle so that rest of the shaft above angle protrudes out and tip faces upwards. Suspend a weight from the tip gradually increasing to 20 N and allow it to act for two minutes. Release the load. No permanent set shall be observed.

6.3 Corrosion Resistance Test

The Sound shall be tested in accordance with IS 7531. It shall show no sign of corrosion after the test. There shall be no red stains or spots on the sound after the test, but dulling of the polished surface may be permitted.

7 MARKING

7.1 The product shall be legibly and indelibly marked with the following:

- a) Manufacturer's name, initials or registered trade-mark;
- b) Country of manufacture; and
- c) The words 'Stainless Steel' or the letters 'SS'

7.2 BIS Certification Marking

The product(s) conforming to the requirements of this standard may be certified as per the conformity assessment schemes under the provisions of the *Bureau of Indian Standards Act, 2016* and the Rules and Regulations framed there under, and the product(s) may be marked with the Standard Mark.

8 PACKING

The instruments shall be wrapped in moisture-proof paper or packed in polyethylene bags avoiding contact with one-another.