

BUREAU OF INDIAN STANDARDS

DRAFT FOR COMMENTS ONLY

(Not to be reproduced without permission of BIS or used as an Indian Standard)

भारतीय मानक मसौदा
कुस्को पैटर्न का योनिक वीक्षणयंत्र – विशिष्टि
(IS 5906: 1970 का पहला पुनरीक्षण)

Draft Indian Standard
**VAGINAL SPECULUM, CUSCO'S PATTERN –
SPECIFICATION**
(First Revision of IS 5906: 1970)

ICS 11.040.30

Obstetric and Gynaecological Instruments
and Appliances Sectional Committee, MHD 03

Last date for comments: 01 May, 2024

FOREWORD

(Formal clause will be added later)

This standard was originally published in 1970. The first revision of this standard has been brought out to align the standard with the latest style and format of Indian Standards.

For the purpose of deciding whether a particular requirement of this standard is complied with the final value, observed or calculated, expressing the result of a test or analysis shall be rounded off in accordance with IS 2: 2022 'Rules for Rounding Off Numerical Values (*second revision*)'. The number of significant places retained in the rounded off value should be same as that of the specified value in this standard.

1 SCOPE

This standard specifies the requirements for vaginal speculum (Cusco's pattern).

2 REFERENCES

The standards given below contain provisions which, through reference in this text, constitute provisions of this standard. At the time of publication, the editions indicated were valid. All standards are subject to revision, and parties to agreements based on this standard are encouraged to investigate the possibility of applying the most recent editions of these standards.

IS No.	Title
IS 6911: 2017	Stainless steel plate, sheet and strip - Specification (<i>second revision</i>)
IS 7531: 1990	Surgical instruments - Corrosion resistance of stainless steel surgical instruments - Methods of tests (<i>first revision</i>)

3 MATERIAL

The material shall be stainless steel conforming to designation X04Cr19Ni9 or X07Cr19Ni9 of IS 6911.

4 SHAPE AND DIMENSIONS

The shape & dimensions shall be as shown in Fig. 1.

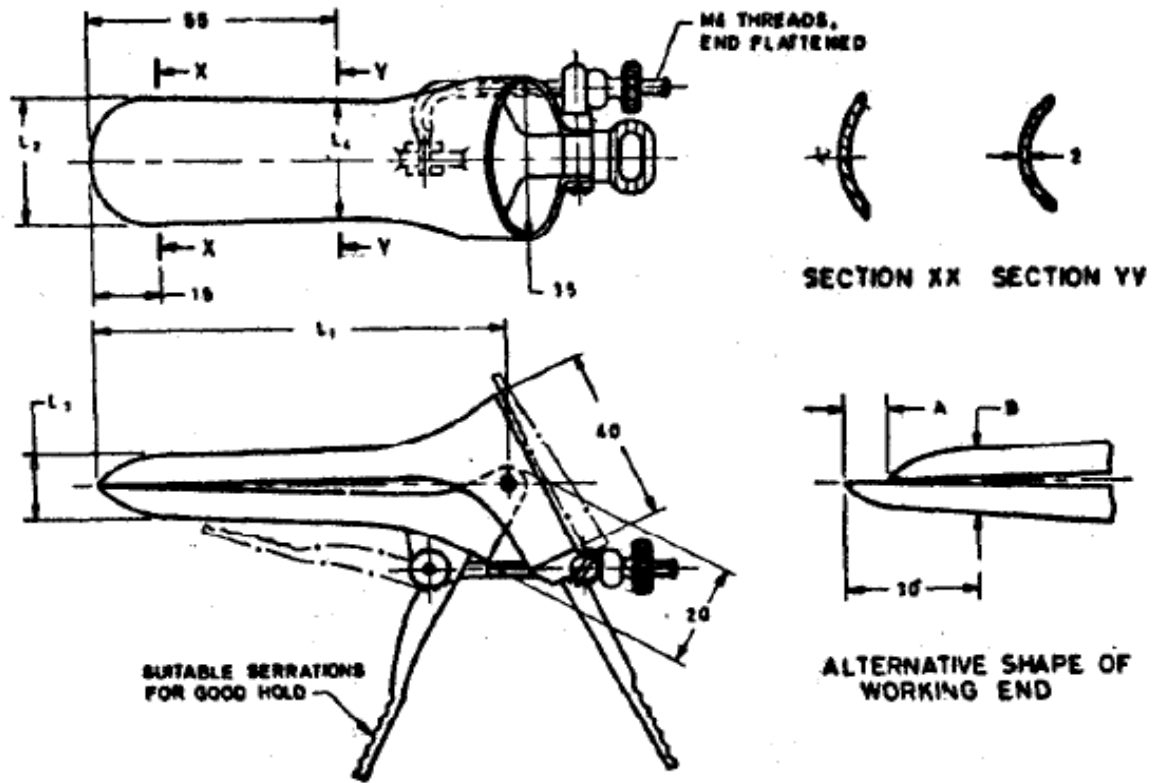

Sizes	L_1	L_a	L_a	L_a	A	B	Maximum Opening of Blades
Extra Small	75	15	10	14	5	12	45
Small	85	20	12	19	8	14	
Medium	95	30	13	28	10	15	
Large	110	35	15	32	12	17	

All dimensions in millimetres.

FIG. 1 SPECULUM, VAGINAL (CUSCO'S PATTERN)

5 WORKMANSHIP AND FINISH

- 5.1 All the surfaces of the speculum shall be free from burrs, pits, cracks and other defects.
- 5.2 The edges of the blades shall be smoothly-rounded and shall not be sharp.
- 5.3 The blades shall move smoothly and freely on the hinge.
- 5.4 Movement of the folding handles and the self-retaining screws shall be smooth.
- 5.5 The speculum shall be passivated and polished bright.

6 TESTS

6.1 Fix the positioning screw for different openings of the blades and press the blades with a force of 50N. The screw shall not slip in any case and no deformation in blades shall be observed after the test.

6.2 Corrosion Resistance Test

Test the sample in accordance with IS 7531. It shall show no sign of corrosion after the test. No red stains or spots on the instrument shall be allowed but dulling of the polished surface may be permitted.

7 MARKING

7.1 The product shall be legibly and indelibly marked with the following:

- a) Manufacturer's name, initials or registered trade-mark;
- b) Country of manufacture; and
- c) The words 'Stainless Steel' or the letters 'SS'

7.2 BIS Certification Marking

The product(s) conforming to the requirements of this standard may be certified as per the conformity assessment schemes under the provisions of the *Bureau of Indian Standards Act, 2016* and the Rules and Regulations framed there under, and the product(s) may be marked with the Standard Mark.

8 PACKING

The speculums shall be wrapped in moisture-proof or packed in polyethylene bags avoiding contact with one another.