

BUREAU OF INDIAN STANDARDS

DRAFT FOR COMMENTS ONLY

(Not to be reproduced without permission of BIS or used as an Indian Standard)

भारतीय मानक मसौदा
सिम्स पैटर्न का डबल-एंडेड शार्प गर्भाशय क्यूरेट – विशिष्टि
(IS 6499: 1971 का पहला पुनरीक्षण)

Draft Indian Standard
**SIM'S PATTERN DOUBLE-ENDED SHARP, UTERINE
CURETTE – SPECIFICATION**
(First Revision of IS 6499:1971)

ICS 11.040.30

Obstetric and Gynaecological Instruments
and Appliances Sectional Committee, MHD 03

Last date for comments: 11 May, 2024

FOREWORD

(Formal clause will be added later)

This standard was originally published in 1971. The first revision of this standard has been brought out to align the standard with the latest style and format of Indian Standards. This revision incorporates Amendment No.1 issued in 1981.

For the purpose of deciding whether a particular requirement of this standard is complied with the final value, observed or calculated, expressing the result of a test or analysis shall be rounded off in accordance with IS 2: 2022 'Rules for Rounding Off Numerical Values (*second revision*)'. The number of significant places retained in the rounded off value should be same as that of the specified value in this standard.

1 SCOPE

This standard provides requirements for double-ended uterine curette, Sim's pattern with both ends sharp.

2 REFERENCES

The standards given below contain provisions which, through reference in this text, constitute provisions of this standard. At the time of publication, the editions indicated were valid. All standards are subject to revision, and parties to agreements based on this standard are encouraged to investigate the possibility of applying the most recent editions of these standards.

<i>IS No.</i>	<i>Title</i>
IS 1570 (Part 5): 1985	Schedules for wrought steels Part 5 Stainless and heat-resisting steels (<i>second revision</i>)
IS 7531: 1990	Surgical instruments – Corrosion resistance of stainless steel surgical instruments – Methods of tests (<i>first revision</i>)

3 MATERIAL

The material shall be of stainless steel conforming to designation X22Cr13 or X30Cr13 as per IS 1570 (Part 5).

4 SHAPE AND DIMENSIONS

The shape & dimensions shall be as shown in Fig. 1.

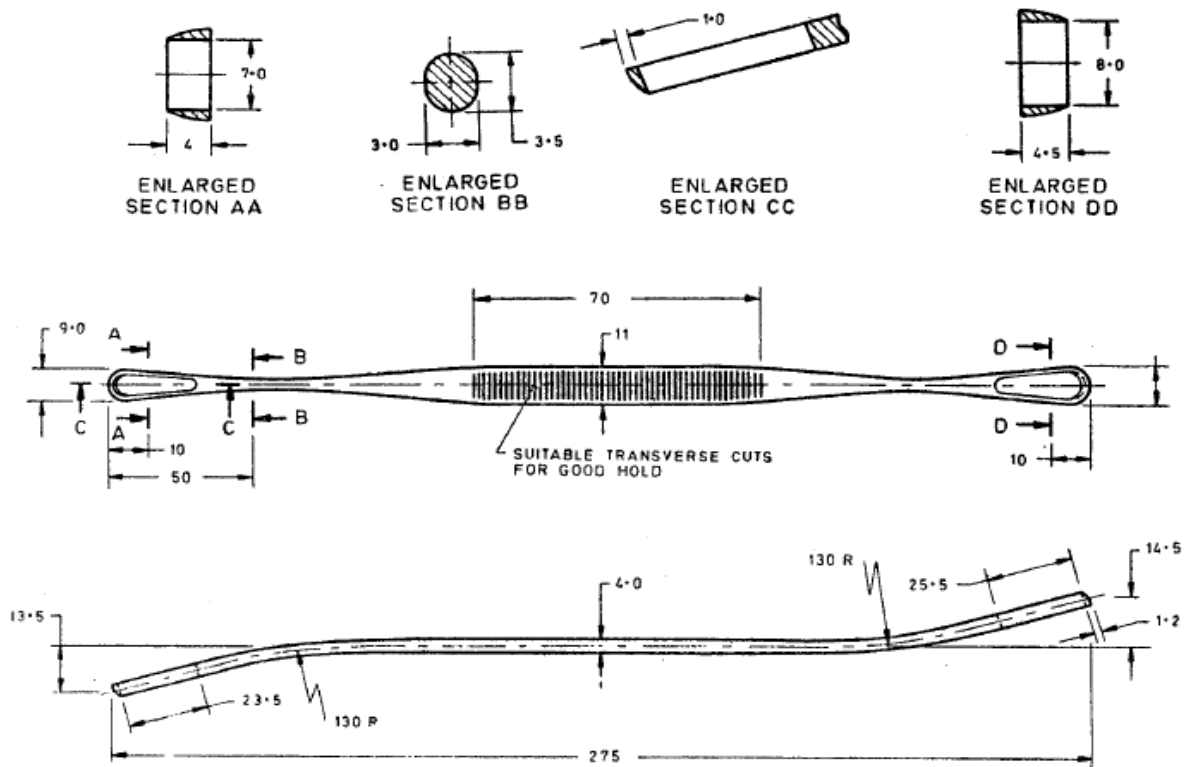

All dimensions in millimetres.

FIG. 1 CURETTE, UTERINE, DOUBLE-ENDED, SHARP, SIM'S PATTERN

5 WORKMANSHIP AND FINISH

- 5.1 The surfaces of the curette shall be free from pits, dents, burrs, scales and other defects.
- 5.2 All the edges shall be even. The edges shall be rounded except the working ends, which shall be semi-sharp.
- 5.3 The curette shall be passivated and polished bright.

6 HEAT TREATMENT

The instrument shall be hardened and tempered to 400 to 450 *HV* measured as near to the working ends as possible.

7 TESTS

- 7.1 Clamp the curette in a vice at the middle of the handle to its long axis. Suspend a load of 30 N gradually on one working end at a distance of 15 mm from the tip. Similarly carry out the test on the other working end. On completion of the test the curette shall show no sign of damage.

7.2 Scrape with one working end of the curette a piece of 6-mm hard millboard quickly and vigorously to and fro 20 times with moderate degree of force. Similarly carry out the test with the other working end. The surface of the millboard shall be scraped easily and cleanly with both the ends, and on completion of the test the curette shall not show any sign of damage or distortion.

7.3 Corrosion Resistance Test

Test the curette in accordance with IS 7531. The curette shall show no sign of corrosion after the test.

8 MARKING

8.1 The product shall be legibly and indelibly marked with the following:

- a) Manufacturer's name, initials or registered trade-mark;
- b) Country of manufacture; and
- c) The words 'Stainless Steel' or the letters 'SS'

8.2 BIS Certification Marking

The product(s) conforming to the requirements of this standard may be certified as per the conformity assessment schemes under the provisions of the *Bureau of Indian Standards Act, 2016* and the Rules and Regulations framed there under, and the product(s) may be marked with the Standard Mark.

9 PACKING

The currettes shall be wrapped in moisture-proof paper or packed in polyethylene bags avoiding contact with one another.