

BUREAU OF INDIAN STANDARDS

DRAFT FOR COMMENTS ONLY

(Not to be reproduced without permission of BIS or used as an Indian Standard)

**भारतीय मानक मसौदा
क्रेनियल रॉंगूर — डाहलग्रेन पैटर्न
(पहला पुनरीक्षण)**

***Draft Indian Standard*
Cranial Rongeur — Dahlgren's Pattern
(First Revision)
[ICS 11.040.30]**

Neurosurgery Instruments, Implants and
Accessories Sectional Committee, MHD-07

Last date for comments: **15 January 2023**

FOREWORD

(Formal clause will be added later)

This standard was originally published in 1977. This revision includes minor changes in references to incorporate the updated designation of steel and the currently used methods of test for hardness and corrosion resistance.

For the purpose of deciding whether a particular requirement of this standard is complied with the final value, observed or calculated, expressing the result of a test or analysis shall be rounded off in accordance with IS 2: 2022 'Rules for Rounding Off Numerical Values (*Second Revision*)'. The number of significant places retained in the rounded off value should be same as that of the specified value in this standard.

1 SCOPE

This standard covers dimensional and other requirement for Dahlgren's pattern cranial rongeur used in neurosurgery.

2 REFERENCES

The standard given below contain provisions which, through reference in this text, constitute provisions of this standard. At the time of publication, the editions indicated were valid. All standards are subject to revision, and parties to agreements based on this standard are encouraged to investigate the possibility of applying the most recent editions of these standards.

<i>IS No.</i>	<i>Title</i>
IS 6603: 2001	Stainless steel bars and flats – Specification (<i>first revision</i>)
IS 7531: 1990	Methods for testing of corrosion resistance of stainless steel surgical instruments (<i>first revision</i>)

3 MATERIAL

Various components of the rongeur shall be made from stainless steel details of which are given below:

<i>S. No.</i>	<i>Components</i>	<i>Material</i>	<i>Conforming to</i>
<i>(1)</i>	<i>(2)</i>	<i>(3)</i>	<i>(4)</i>
I)	Arms and springs	Stainless steel	Designation X30Cr13 of IS 6603:2001
II)	Blade	Stainless steel	Designation X40Cr13 of IS 6603:2001
III)	Screws	Stainless steel	Designation X20Cr13 of IS 6603:2001

4 SHAPE AND DIMENSIONS

Shall be as shown in Fig. 1 and 2.

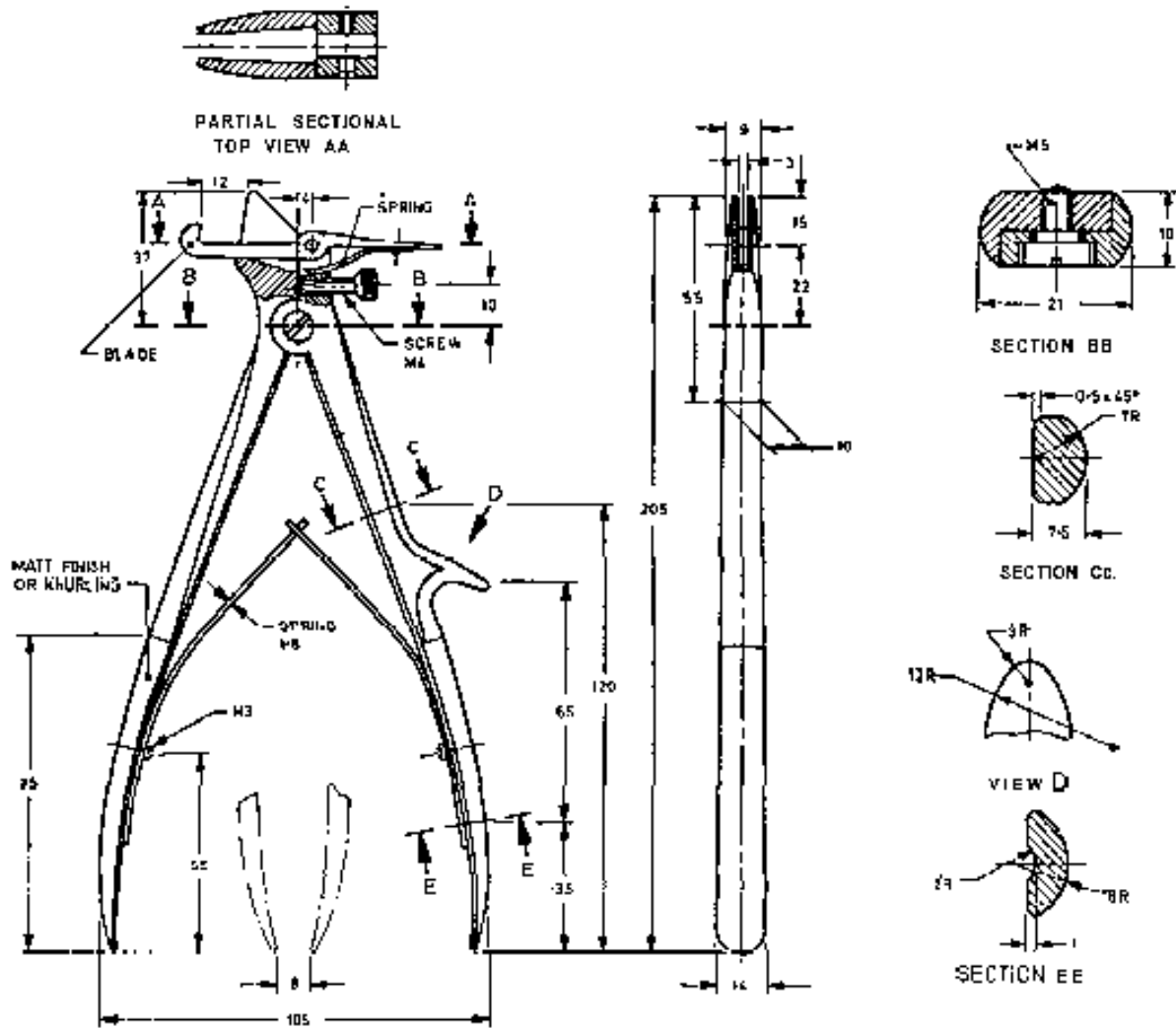

All dimensions in millimetres
 FIG. 1 CRANIAL RONGEUR, DAHLGREN'S PATTERN

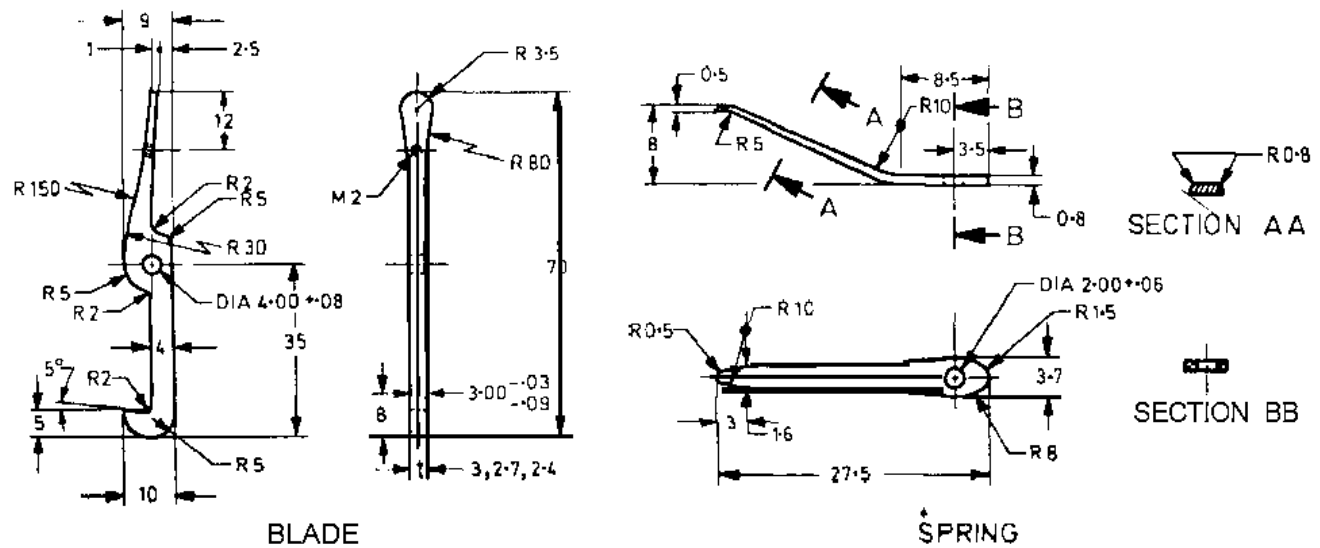

All dimensions in millimetres.
FIG. 2 DETAILS OF BLADE AND SPRING

A deviation of ± 2.5 percent shall be allowed on all dimensions except where specified.

5 MANUFACTURE, WORKMANSHIP AND FINISH

5.1 The rongeur shall be free from pits, burrs, scales, sharp edges, cracks and other surface defects on its external as well as internal surfaces.

5.2 The rongeur shall be provided with three blades (Fig. 2) having thickness of working edges as 3 mm, 2.7 mm and 2.4 mm respectively. The blade shall slide between the guides without any stiffness or undue play during use. The working edge of the blade shall be smooth and free from nicks and other defects.

5.3 The front face of the blade guide (see Fig. 1) shall be knurled to prevent slipping during operation.

5.4 The joints shall have no undue play, and shall work smoothly.

5.5 The screws shall be well formed and shall have regular threads.

5.6 The spring action shall be smooth. It shall be neither too hard nor too slack,

5.7 The rongeur shall be polished bright and passivated. The gripping portion of arms shall be matt finished.

6 HEAT TREATMENT

Various components of rongeur shall be suitably hardened and tempered to give hardness as indicated below:

- a) 510 to 595 HV for blades,
- b) 410 to 470 HV for arms and springs, and
- c) 290 to 320 HV for screws.

7 TESTS

7.1 Performance Test – Each rongeur shall be made to nibble the skull bone or teakwood of 3/4 cm thickness five times with each blade. On completion of the test, the blades as well as the rongeur shall show no sign of damage.

7.2 Rigidity Test – A compressive force of 110 N shall be applied to the rongeur arms at a distance of 75 mm from free ends in such a manner that it tends to press the arms together. The maximum force shall be attained gradually and shall act for two minutes. On completion of the test, the rongeur shall show no sign of damage.

7.3 Corrosion Resistance Test - The rongeur shall conform to the requirements of IS 7531: 1990.

8 BIS CERTIFICATION MARKING

The product(s) conforming to the requirements of this standard may be certified as per the conformity assessment schemes under the provisions of the Bureau of Indian Standards Act, 2016 and the Rules and Regulations framed thereunder, and the product(s) may be marked with the Standard Mark.

9 PACKING

Each instrument shall be packed as agreed to between the purchaser and the manufacturer or in accordance with the current trade practices.