

BUREAU OF INDIAN STANDARDS

DRAFT FOR COMMENTS ONLY

(Not to be reproduced without permission of BIS or used as an Indian Standard)

भारतीय मानक मसौदा
खून दाता का सोफ़ा

Draft Indian Standard
Blood Donor Couch

ICS 11.040.01

Hospital Equipment and Surgical Disposable
Products Sectional Committee, MHD 12

Last date for comments: 25 Sep 2023

FOREWORD

(Formal clause will be added later)

The blood donor couch is designed to make blood withdrawals easier, safe and provide a comfortable seating position to the donor during blood donation process. It has various features including adjustment of height, arm, and position. Donor's position can be easily adjusted to form either a comfortable easy chair or a bed.

The clauses 4.2.2, 4.3, 4.7, 4.8, 4.10, 4.11, 4.12, 4.13, 4.14, 4.18 c and 10 of this standard is depends upon the mutual agreement between supplier/manufacture and purchaser.

The Standard guidelines for a user/service manual shall be in accordance with IEC/IEEE 82079-1:2019, Preparation of information for use (instructions for use) of products - Part 1 Principles and general requirements and EN 1041 standard – information supplied by the manufacturer of medical device.

For the purpose of deciding whether a particular requirement of this standard is complied with the final value, observed or calculated, expressing the result of a test or analysis shall be rounded off in accordance with IS 2: 2022 'Rules for rounding off numerical values (*Second Revision*)'. The number of significant places retained in the rounded off value should be same as that of the specified value in this standard.

1. SCOPE

This standard covers the requirements of blood donor couch used in blood bank for blood donation and apheresis procedure during blood donation.

2. REFERENCES

The standards listed below contain provisions which, through reference in this text, constitute provisions of this standard. At the time of publication, the editions indicated were valid. All standards are subject to revision, and parties to agreements based on this standard are encouraged to investigate the possibility of applying the most recent editions of the standards listed below.

<i>IS No.</i>	<i>Title</i>
IS 577 : 1986	Upholstery leather (<i>first revision</i>)
IS 1068 : 1993	Electroplated coatings of nickel plus chromium and copper plus nickel plus chromium (<i>third revision</i>)
IS 2039 : 1991	Steel tubes for bicycle and cycle rickshaws - Specification (<i>second revision</i>)
IS 4033 : 1968	General requirements for hospital furniture
IS 4034 : 1979	Castors for hospital equipment (<i>first revision</i>)
IS 5528 : 1985	Method of testing corrosion resistance of electroplated and anodized aluminum coating by copper accelerated acetic acid salt spray (CASS) test (<i>first revision</i>)
IS 6911 : 2017	Stainless steel plate, sheet and strip - Specification (<i>second revision</i>)
IS 8255 : 1976	Flexible load rearing polyurethane foam components for vehicles
IS 12467 (Part 1) : 2006	Textiles - Assessment of the ignitability of upholstered furniture Part 1 - Ignition source: Shouldering cigarette (<i>first revision</i>)
IS 12467 (Part 2) : 2006	Textiles - Assessment of the ignitability of upholstered furniture Part 2 - Ignition source: Match flame equivalent (<i>first revision</i>)
IS 13450 (Part 1): 2018/IEC 60601-1 : 2012	Medical electrical equipment - Part 1 General requirements for basic safety and essential performance (<i>second revision</i>)
IS 13450 (Part 1/Sec 2): 2018/IEC 60601-1-2 : 2014	Medical electrical equipment - Part 1 General requirements for the basic safety and essential performance - Section 2 : Collateral standard : Electromagnetic disturbances - Requirements and tests (<i>first revision</i>)

3. COMPONENTS

3.1 The frame body material shall be made of electric resistance butt-welded steel tube (ERW) conforming to IS 2039, shall be rust-free and shall be shall be plated chromium over nickel in accordance with Service Grade No. 3 of IS 1068 or powder coated to prevent rusting. Mild steel sheets strip as specified in IS 6911 shall be used for base of the frame. The body fabricated shall

be in compliance with IS 4033. The frame shall be provided with four non-skid lockable castors conforming to IS 4034 for easy movement of the blood donor couch.

NOTE: Other suitable material as agreed between manufacturer and purchaser is also acceptable, subject to compliance to other requirements of this Standard.

3.2 Interwoven high grade leatherette as specified in IS 577 shall be used as upholstery for the blood donor couch.

3.3 Non-deformable soft Polyurethane (PU) foam as per IS 8255 shall be used in the blood donor couch to provide cushioned comfort to the patient.

4. CONSTRUCTIONAL REQUIREMENTS

4.1 The blood donor couch outer body shall have comfortable sitting for patient which should allow change in posture through smooth motorized movement in height, leg section and back section.

4.2.1 The operator shall be able to tilt the blood donor couch manually or through simple control. The blood donor couch shall achieve flatbed position, sitting posture, Trendelenburg position, High head-low feet position and Head low-high feet position (with angle of minimum 8°-10° angle). The recommended possible adjustments are as follows:

- a) Back rest tilt - 0° to 70°
- b) Seat rest tilt - 0° to 20°
- c) Leg rest tilt - 0° to 30°

4.2.2 For single motor donor couch/van couch can have desired dimensions and multiple movement as per the agreement between purchaser and the supplier.

4.3 The seat cushion of the blood donor couch may be removable. Both the broad arm rest of the blood donor couch shall be adjustable for height, vertical and horizontal position for achieving right hand position during blood donation or apheresis.

4.4 The blood donor couch shall be able to quickly achieve head-low position in case of vasovagal attack to donor or other emergency with single touch button.

4.5 The blood donor couch shall have non-deformable foam of thickness between 60-100 mm for comfortable sitting for long time.

4.6 The blood donor couch shall have antimicrobial treated washable upholstery for maintaining hygiene. The upholstery shall be resistant to liquid adsorption. The upholstery and padding of the blood donor couch shall be flame resistant. The Testing for Cleaning and disinfection of blood donor couch shall be carried out in accordance with ISO 17664:2017.

4.7 The blood donor couch, if required by the purchaser, may have adjustable multi tray IV stand for keeping all the blood donation related accessories.

4.8 The blood donor couch, if required by the purchaser, shall have PU non-skid lockable castors for stable position of patient allowing easy transfer of patient.

4.9 The blood donor couch shall be suitable for weight carrying capacity of upto 150 kg.

4.10 The blood donor couch may be provided with a belt (optional) to support the donor during emergency shifting.

4.11 The blood donor couch may have provision to accommodate the portable food table.

4.12 The unit may have storage drawers for storing consumables and blood collection monitors.

4.13 A paper roll holder may be integrated in the couches to hold the paper to keep the seat hygienic in case of any spillage.

4.14 Melodious musical headphone, reading lamp may be integrated for patient relaxation while blood donation is in progress.

4.15 All exterior parts of the blood donor couch shall be capable of being cleaned and disinfected, using agents recommended by the manufacturer, without deteriorating the couch surface and markings.

4.16 Environmental factor: The blood donor couch shall be capable of operating continuously in ambient temperature of 10-40 °C and relative humidity of 15-90%. The unit shall be capable of being stored continuously in ambient temperature of 0-40 °C and relative humidity of 15-90%.

4.17 Electrical Safety and EMC Requirements (only for electrically operated couches) : The electrically operated blood donor couch shall meet the specifications of IS 13450 (Part 1)/ IEC 60601-1 and IS 13450 (Part 1/ Sec 2) / IEC 60601-1-2.

4.18 Power Supply (only for electrically operated couches):

- a) Power input: 220-240V/ 50 Hz AC Single phase fitted with appropriate plugs and sockets shall be provided.
- b) Suitable Servo controlled stabilizer may be provided.
- c) Fuse/resettable over current circuit breaker shall be fitted for protection during power surge.

4.19 All electrical actuators and mechanisms should be housed inside couch making it safer (only for electrically operated couches).

5. WORKMANSHIP AND FINISH

5.1 The outer body of the blood donor couch shall be rust proof with long lasting performance.

5.2 The blood donor couch shall have round corner frame design and free from welding defects, sharp corners or any other protrusion/projections which may cause injury.

5.3 The upholstery should be resistant to water and conducive to the comfort of the patient seated for extended periods, and over periods in which temperature and humidity may change.

5.4 Controls, if provided for the adjustment of the seat and backrest, should be arranged and located so as to render their accidental actuation unlikely.

5.7 Moving parts that may constitute a hazard under normal working conditions should be protected or guarded to minimize the risk of injury to the operator or donor or any other personnel.

6. SHAPE AND DIMENSION

6.1 The typical shape may be as given in **Figure 1**.

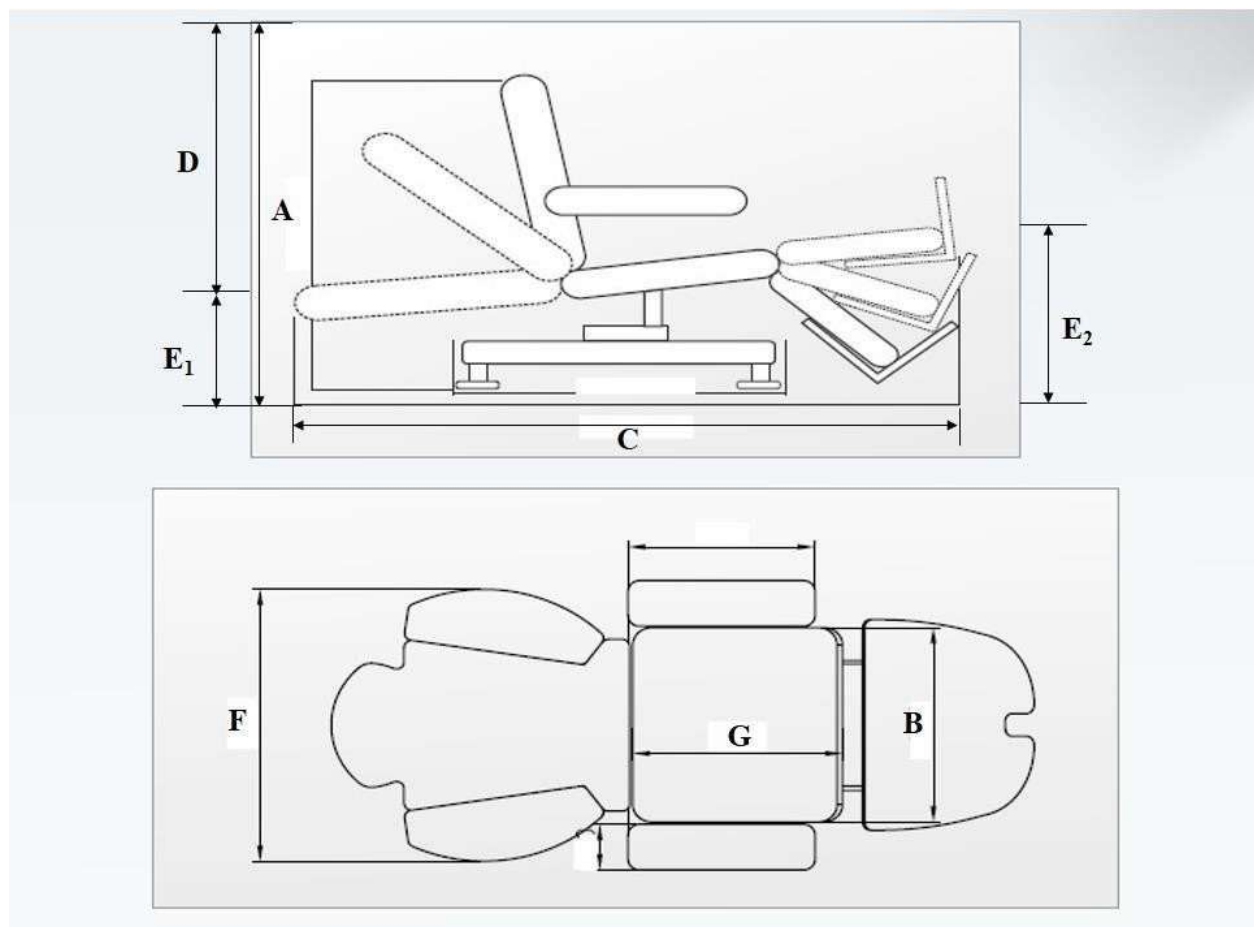

Figure 1: Illustrative diagram for a blood donation couch

NOTE: The diagram shown above in **Figure 1** is only for representation purpose, design of the chair shown here is for illustrative purpose only.

6.2 Recommended dimensions of various basic parts of the blood donation couch shall be as follows:

- 6.2.1 Back seat height should be between 1300 mm to 1500 mm (dimension **A** of Fig. 1).
- 6.2.2 Cushion width should be approximately 600 mm (dimension **B** of Fig. 1).
- 6.2.3 Reclining total length should be between 1800 mm to 1900 mm (dimension **C** of Fig. 1).
- 6.2.4 Back cushion length should be approximately 500 mm (dimension **D** of Fig. 1).
- 6.2.5 Reclined height at each end should be 650 mm (dimensions **E₁** of Fig. 1) and 800 mm (dimensions **E₂** of Fig. 1).
- 6.2.6 Headrest should be 400 mm (height) × 500 mm (width).
- 6.2.7 Full chair width should be 900 mm (dimension **F** of Fig. 1).
- 6.2.8 Seat cushion length should be 500 mm (dimension **G** of Fig. 1).
- 6.2.9 Cushioned arm rest should be of 500 mm (length) × 200 mm (width).
- 6.2.10 Couch should be rigidly mounted on base platform measuring 1000 mm (length) × 750 mm (width).
- 6.2.11 Leg support should be of 400 mm (height) × 500 mm (width)/ 250 mm (bottom).

NOTE: The above dimensions are only for guidance. Other dimensions as agreed between manufacturer and purchaser are also permitted, subject to compliance to other requirements of this Standard.

6.3 Tolerances on dimensions shall be ± 10% on declared values.

7. TESTS

7.1 The blood donor couch shall be subjected to tests in accordance with the requirements of relevant specifications.

7.2 Visual inspection shall be performed at normal visual acuity without magnification. There should be no visible surface defects, constructional defects or other deformities.

7.3 Adhesion Test: For the painted portion of the blood donor couch, adhesion test is carried out. A square measuring (12 to 15 mm) shall be marked over conveniently selected spot on the painted portion and cross lines, at a distance of 1 to 1.5 mm apart and inclined at 120°, shall be inscribed over the marked portion with a pointed instrument. Thereafter, cello-tape shall be rubbed down over this portion and left for two minutes; after which it shall be jerked free from the painted surface. If more than 5 percent of the squares had ripped away from the painted surface and are adhering to the cello-tape, the portion shall be repainted and again subjected to this test now at two conveniently selected spots and the item considered passing only if it satisfies in both the cases.

7.4 Corrosion resistance Test: The coated/electro-plated components shall be sufficiently corrosion-resistant and pore-free to pass the appropriate test specified in IS 1068 or IS 5528 for the particular service condition number.

7.5 Performance Test: When the blood donor couch is pushed over a level and even surface with load (load to be as laid down in relevant specifications), it shall not wobble or rattle. It shall also move freely when pulled in circular motion and the castors shall face in the same direction without normal force. The blood donor couch shall be operated at moderate speed and shall turn and steer without difficulty of operation, structural or component failure.

7.7 Stability Test: The blood donor couch shall be tested for static load test in reclined position as well as in vertical seating position. It shall be loaded with sand bags weights totaling up to 300 kg load. It shall be subjected for this load for not less than 15 minutes. There shall be no damage or permanent set after the test. The blood donor couch shall operate normally after removal of the load.

7.8 Flammability: Testing for flammability of upholstery shall be carried out in accordance with IS 12467 (Part 1) and IS 12467 (Part 2).

8. MANUFACTURER'S INSTRUCTIONS FOR USE

8.1 The manufacturer shall supply instructions for the safe operation and use of the blood donor couch. The instructions shall include step-by-step procedures for operating and maintaining the blood donor couch, with illustrations showing the location of the controls, together with explanations of their use.

8.2 The instructions for use shall also include the following information:

- a) Range of adjustment of seat height;
- b) Seat depth;
- c) Seat width;
- d) Range of backrest adjustment;
- e) List of equipment available for providing calibration and routine maintenance support as per manufacturer documentation in service / technical manual;
- f) Recommendations for cleaning and disinfecting agents, together with instructions for their use;
- g) Precautions regarding safe use of blood donor couch.

9. MARKING

9.1 The body of blood donor couch shall be indelibly and clearly marked with:

- a) Manufacturer's name or trademark;
- b) Model;
- c) Unique device identification number
- d) 'Read instructions before use'.

9.2 The packages shall also be marked with make or manufacture's trade-mark.

9.3 BIS Certification Marking

The product(s) conforming to the requirements of this standard may be certified as per the conformity assessment schemes under the provisions of the *Bureau of Indian Standards Act*,

2016 and the Rules and Regulations framed thereunder, and the product(s) may be marked with the Standard Mark.

10. PACKAGING

The blood donor couch shall be packaged for transportation in such a way that no damage can occur during anticipated transport conditions. The packaging shall be marked with 'Handling instructions' on the package to facilitate handling of blood collection monitor. Assembly/installation details need to be in the instruction for use.