

**BUREAU OF INDIAN STANDARDS**

**DRAFT FOR COMMENTS ONLY**

*(Not to be reproduced without permission of BIS or used as an Indian  
Standard)*

भारतीय मानक मसौदा

**डायलिसिस चेयर**

*Draft Indian Standard*

**Dialysis Chair**

**[ICS 11.040.01]**

Hospital Equipment and Surgical Disposable  
Products Sectional Committee, MHD 12

Last date for comments: 18 Oct 2023

**FOREWORD**

*(Formal clause will be added later)*

Dialysis chairs are designed to assist and facilitate the work of physicians and medical staff in dialysis centers. It provides comfort to the patients during treatment. This chair can also be adjusted electrically to form a comfortable easy chair or a bed like couch. It requires less space than a conventional hospital bed.

The clauses 4.6 and 10 of this standard is depend upon the mutual agreement between supplier/manufacturer and purchaser.

For the purpose of deciding whether a particular requirement of this standard is complied with the final value, observed or calculated, expressing the result of a test or analysis shall be rounded off in accordance with IS 2: 2022 'Rules for Rounding Off Numerical Values (*Second Revision*)'. The number of significant places retained in the rounded off value should be same as that of the specified value in this standard.

## 1. SCOPE

- 1.1** This standard describes the requirements of dialysis chair used in dialysis centers and nephrology departments of hospitals for conducting dialysis procedure on patients.
- 1.2** The dialysis chair can be manually/Electrically operated.

## 2. REFERENCES

The standards listed below contain provisions which, through reference in this text, constitute provisions of this standard. At the time of publication, the editions indicated were valid. All standards are subject to revision, and parties to agreements based on this standard are encouraged to investigate the possibility of applying the most recent editions of the standards listed below.

<i>IS No.</i>	<i>Title</i>
IS 577 : 1986	Upholstery leather ( <i>first revision</i> )
IS 1068 : 1993	Electroplated coatings of nickel plus chromium and copper plus nickel plus chromium ( <i>third revision</i> )
IS 2039 : 1991	Steel tubes for bicycle and cycle rickshaws - Specification ( <i>second revision</i> )
IS 4033 : 1968	General requirements for hospital furniture
IS 4034 : 1979	Castors for hospital equipment ( <i>first revision</i> )
IS 5528 : 1985	Method of testing corrosion resistance of electroplated and anodized aluminum coating by copper accelerated acetic acid salt spray (CASS) test ( <i>first revision</i> )
IS 6009 : 1970	Method for evaluation of results of accelerated corrosion tests
IS 8255 : 1976	Flexible load rearing polyurethane foam components for vehicles
IS 12467 (Part 1) : 2006	Textiles - Assessment of the ignitability of upholstered furniture Part 1 - Ignition source: Shouldering cigarette ( <i>first revision</i> )
IS 12467 (Part 2) : 2006	Textiles - Assessment of the ignitability of upholstered furniture Part 2 - Ignition source: Match flame equivalent ( <i>first revision</i> )
IS 13450 (Part 1) : 2018 / IEC 60601-1 : 2012 (Ed 3.1)	Medical electrical equipment - Part 1 General requirements for basic safety and essential performance ( <i>second revision</i> )
IS 13450 (Part 1/Sec 2) : 2018 / IEC 60601-1-2 : 2014	Medical electrical equipment - Part 1 : General requirements for the basic safety and essential performance - Section 2 : Collateral standard : Electromagnetic disturbances -

Requirements and tests (*first revision*)

IS/ISO 16142 - 1:2016	Medical Devices — Recognized Essential Principles of Safety and Performance of Medical Devices Part 1 General Essential Principles and Additional Specific Essential Principles for all Non-IVD Medical Devices and Guidance on the Selection of Standards
IS/ISO 17664:2017	Processing of Health Care Products — Information to be provided by the Medical Device Manufacturer for the Processing of Medical Devices
IS 13450 (Part 1) : 2018/IEC 60601-1:2012	Medical electrical equipment: Part 1 general requirements for basic safety and essential performance (Second Revision)

### **3. COMPONENTS**

**3.1** The frame body material shall be made of powder coated mild steel to prevent rusting. The frame shall be provided with four non-skid lockable castors for easy movement of the dialysis chair.

**3.2** Interwoven high grade leatherette as specified in **IS 577** shall be used as upholstery for the dialysis chair.

**3.3** Non-deformable soft Polyurethane (PU) foam as per **IS 8255** shall be used in the dialysis chair to provide cushion and comfort to the patient.

### **4. CONSTRUCTIONAL REQUIREMENTS**

**4.1** The dialysis chair outer body shall have comfortable sitting for patient which should allow change in posture through smooth motorized movement in height, leg section and back section.

**4.2** The dialysis chair shall have slide out lockable foot stool which allows the patient to step down from the chair safely.

**4.3** The dialysis chair shall achieve flatbed position, sitting posture, Trendelenburg position and Head-low position (with angle of minimum 10°-12° angle). The recommended possible adjustments are as follows:

- a) Back rest tilt - 12° to 80°
- b) Seat rest tilt – Same as specified
- c) Leg rest tilt - 80° to 12°; Leg position is essential for position during cramps of dialysis.

**4.4** The dialysis chair shall have cleaning and disinfection facility for maintaining hygiene in accordance with IS/ISO 17664. It shall be resistant to liquid adsorption.

**4.5** The seat cushion of the dialysis chair shall be removable. Both the broad arm rest of the chair shall be adjustable for height, vertical and horizontal position for achieving right hand position during dialysis.

**4.6** Round Handle: The dialysis chair shall have a round handle for nurses to move the dialysis chair. The dialysis chair shall have 40 mm x125 mm swivel castor with central brake.

**4.7** The dialysis chair shall be able to quickly achieve head-low position in case of emergency with single touch button.

**4.8** IV pole: For the convenience of nurses, the dialysis chair shall have an area to place the IV pole either at the front or the rear.

**4.9** The dialysis chair shall have fold out tray arms for patients to place their belongings or rest

their arms.

**4.10** CPR legs: The dialysis chair shall have provision for CPR legs to support the CPR position.

**4.11** The dialysis chair, if required by the purchaser, shall have PU non-skid lockable castors for stable position of patient allowing easy transfer of patient.

**4.12** The dialysis chair shall have non-deformable foam of thickness between 60-100 mm for comfortable sitting for long time.

**4.13** The dialysis chair, if required by the purchaser, shall have adjustable multi tray IV stand for keeping all dialysis related accessories.

**4.14** The dialysis chair shall be suitable for a weight carrying capacity of upto 150 kg.

**4.15** The dialysis chair shall be provided with a belt to support the patient during shifting.

**4.16** The dialysis chair shall have provision to accommodate the portable food table.

**4.17** The electrically operated dialysis chair shall have weight monitoring capability upto 200 kg.

**4.18** The battery backup inside the electrically operated chair shall be as per IS 13450 (Part 1)

**4.19** Hand Control: The electrically operated chair shall have two hand controls. One nurse operated hand control and one patient operated hand control. The patient individual hand control allows operation of the seat/footrest and backrest position for comfortable position during the procedure. The nursing staff should have control of Hi/Lo function only and this should be at the rear of the chair.

**4.20** All exterior parts of the dialysis chair shall be capable of being cleaned and disinfected, using agents recommended by the manufacturer, without deteriorating the chair's surface and markings.

**4.21** The upholstery and padding of the dialysis chair shall be flame resistant.

## **5 Environmental factor**

The dialysis chair shall be designed to withstand and capable of operating continuously in ambient temperature of 10-40 °C and relative humidity of 15-90%.

## **6 Electrical Safety and EMC Requirements (only for electrically operated couches)**

The electrically operated dialysis chair shall meet the specifications of IS 13450 (Part 1)/ IEC 60601- 1 and IS 13450 (Part 1/ Sec 2) / IEC 60601-1-2.

6.1 The dialysis chair may have the provision for weight monitoring facility for immobilized patient.

## **7.WORKMANSHIP AND FINISH**

7.1 The outer body of the dialysis chair shall be rust proof with long lasting performance.

7.2The dialysis chair shall have round corner frame design and free from welding defects, sharp corners or any other protrusion/projections which may cause injury.

7.3The upholstery should be resistant to water and conducive to the comfort of the patient seated for extended periods, and over periods in which temperature and humidity may change.

7.4Controls, if provided for the adjustment of the seat and backrest, should be arranged and located so as to render their accidental actuation unlikely.

7.5Moving parts that may constitute a hazard under normal working conditions should be protected or guarded to minimize the risk of injury to the operator or other personnel and occupant of the chair.

## **8.SHAPE AND DIMENSION**

8.1The typical shape may be as given in Figure 1.

8.2 Recommended dimensions of various basic parts of the chair shall be as follows:

8.2.1 Back seat height should be between 1300 mm to 1500 mm.

8.2.2 Cushion should be approximately 600 mm × 500 mm in size.

8.2.3 Reclining total length should be between 1880 mm to 1900 mm.

8.2.4 Back cushion length should be approximately 500 mm.

8.2.5 Reclined heights at each end should be 650 and 800 mm.

8.2.6 Headrest should be 400 mm (height) × 400 mm (top)/ 500 bottom width approximately.

8.2.7 Full chair width should be 900 mm approximately.

8.2.8 Cushioned arm rest should be of 500 mm (length) × 200 mm (width).

8.2.9 Reclined base to floor height should range from 500 mm and up to 700 mm.

8.2.10 Overall dimension of frame shall not exceed 1000 mm (length) × 750 mm (width).

8.2.11 Leg support should be of 400 mm (height) × 500 mm (width)/ 250 mm (bottom).

**NOTE:** The above dimensions are only for guidance. Other dimensions as agreed between manufacturer and purchaser are also permitted, subject to compliance to other requirements of this Standard.

8.3 Tolerances on dimensions shall be ± 10% on declared values.

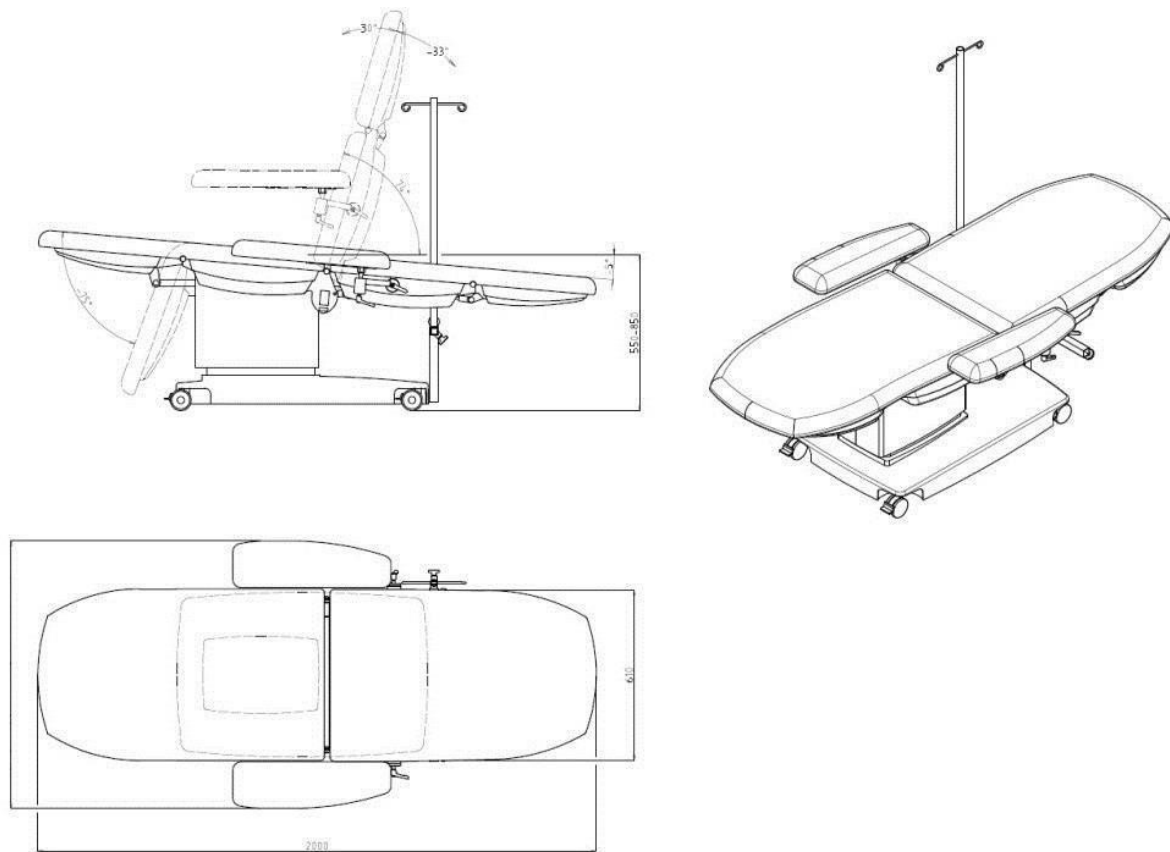

**Figure 1** : Generalized diagram for a typical dialysis chair

**NOTE:** The diagram shown above in **Figure 1** is only for representation purpose, design of the chair shown here is for illustrative purpose only.

## 9. TESTS

9.1 The dialysis chair shall be subjected to tests in accordance with the requirements of relevant specifications.

9.2 Visual inspection shall be performed at normal visual.

9.3 **Adhesion Test:** For the painted portion of the dialysis chair, adhesion test is carried out. A square measuring (12 to 15 mm) shall be marked over conveniently selected spot on the painted portion and cross lines, at a distance of 1 to 1.5 mm apart and inclined at  $120^\circ$ , shall be inscribed over the marked portion with a pointed instrument. Thereafter, cello-tape shall be rubbed down over this portion and left for two minutes; after which it shall be jerked free from the painted surface. If more than 5 percent of the squares had ripped away from the painted surface and are adhering to the cello-tape, the portion shall be repainted and again subjected to this test now at two conveniently selected spots and the item considered passing only if it satisfies in both the cases.

9.4 **Corrosion resistance Test:** The coated/plated components shall be sufficiently corrosion-resistant and pore-free to pass the appropriate test specified in IS 1068 or IS 5528 for the

particular service condition number. The performance rating shall be determined in accordance with IS 6009 to each tested article representing the relative freedom from defects at which coating is penetrated, with resulting the corrosion of the basis metal.

**9.5 Performance Test:** When the chair is pushed over a level and even surface with load (load to be as laid down in relevant specifications), it shall not wobble or rattle. It shall also move freely when pulled in circular motion and the castors shall face in the same direction without normal force.

**9.6 Maneuverability Test:** The chair shall be operated at moderate speed and shall turn and steer without difficulty of operation, structural or component failure.

**9.7 Stability Test:** The chair shall be tested for static load test in reclined position as well as in vertical seating position. It shall be loaded with sand bags weights totaling up to 300 kg load. It shall be subjected for this load for not less than 15 minutes. There shall be no damage or permanent set after the test. The chair shall operate normally after removal of the load.

**9.8 Flammability:** Testing for shall be carried out in accordance with IS 12467 (Part 1) and IS 12467 (Part 2).

**9.9 Cleaning and Disinfection Mechanism** The dialysis chair shall have cleaning and disinfection facility for maintaining hygiene in accordance with IS/ISO 17664.

9.10 The Essential principles of safety and performance of medical devices to be complied as per IS/ISO 16142 - 1.

## 10. MANUFACTURER'S INSTRUCTIONS FOR USE

10.1 The manufacturer shall supply instructions for the safe operation and use of the dialysis chair. The instructions shall include step-by-step procedures for operating and maintaining the chair, with illustrations showing the location of the controls, together with explanations of their use.

10.2 The instructions for use shall also include the following information:

- a) Range of adjustment of seat height;
- b) Seat depth;
- c) Seat width;
- d) Range of backrest adjustment;
- e) Recommendations for cleaning and disinfecting agents, together with instructions for their use;
- f) Precautions regarding safe use of chair;
- g) Programming instructions in the electrically operated chair with a maximum of three positions programmed into the memory; and
- h) Recalibration: if there is loss of feedback from the actuators, a position lost beep sounds and recalibration can be done via the Nurse's control.

## 11. MARKING

11.1 The body of dialysis chair shall be indelibly and clearly marked with:

- a) Manufacturer's name or trademark;
- b) Model;



- c) Unique device identification number
- d) Read instructions before use

**11.2** The packages shall also be marked with make or manufacture's trade-mark.

### **11.3 BIS Certificate Marking**

The product(s) conforming to the requirements of this standard may be certified as per the conformity assessment schemes under the provisions of the *Bureau of Indian Standards Act, 2016* and the Rules and Regulations framed thereunder, and the product(s) may be marked with the Standard Mark.

## **12. PACKAGING**

The dialysis chair shall be packaged for transportation in such a way that no damage can occur during anticipated transport conditions. The packaging shall be marked with 'Handling Instructions' on the outside of the package to facilitate handling/assembly and installation of the chair. The packaging shall be as agreed to between the purchaser and the manufacturer/supplier.