

BUREAU OF INDIAN STANDARDS

DRAFT FOR COMMENTS ONLY

(Not to be reproduced without permission of BIS or used as an Indian Standard)

भारतीयमानकमसौदा

पुनर्वासउपकरण— पहिये वाली कुर्सियां, फोल्डिंग,

छोटा साईज — व शष्टि

[IS 8086 का दूसरा पुनरीक्षण]

Draft Indian Standard

**Rehabilitation Equipment —
Wheelchairs, Folding, Junior Size —
Specification**

[Second Revision of IS 8086]

ICS 11.180.10

Artificial Limbs, Rehabilitation Appliances and
Equipment for the Person with Disability Sectional
Committee, MHD 09

Last date for comments:
12 January 2023

FOREWORD

(Formal clause will be added later)

This standard was first published in 1976 and was revised in 1991. The significant changes in this revision ensure that the chair is built in such a manner as to adopt various commonly used accessories. This standard permits the use of high strength, low weight steel tubing, shouldering action and an inclined seat.

For the purpose of deciding whether a particular requirement of this standard is complied with the final value, observed or calculated, expressing the result of a test or analysis shall be rounded off in accordance with IS 2: 2022 'Rules for rounding off numerical values (*second revision*)'. The number of significant places retained in the rounded off value should be same as that of the specified value in this standard.

1 SCOPE

1.1 This standard specifies the requirements for folding wheelchairs used by invalid children.

1.2 This standard covers only the requirements of Type 1 and Type 2 wheelchairs (*see 4.1*). Types 3, 4, 5, 6, 7, 8, 9, and Type 0 wheelchairs (*see 4.1*) are not covered in this standard.

2 REFERENCES

The standards given below contain provisions which, through reference in this text, constitute provisions of this standard. At the time of publication, the editions indicated were valid. All standards are subject to revision, and parties to agreements based on this standard are encouraged to investigate the possibility of applying the most recent editions of these standards.

<i>IS No.</i>	<i>Title</i>
IS 1586 (Part 1)	Metallic materials - Rockwell hardness test: Part 1 test method (<i>Fifth Revision</i>)
IS 1068 : 1993	Electroplated coatings of nickel plus chromium and copper plus nickel plus chromium - Specification (<i>Third Revision</i>)
IS 1868 : 1996	Anodic coatings on aluminum and its alloys - Specification (<i>Third Revision</i>)

3 TERMINOLOGY

The terminology for the wheelchairs is indicated in Fig. 1.

4 TYPES

The type classification of the wheelchairs according to the means of propulsion/steering shall be as follows:

- Type 1 Attendant controlled — non-powered
- Type 2 Non-powered direct drive on rearwheels, bimanual
- Type 3 Non-powered direct drive on frontwheels, bimanual
- Type 4 Non-powered lever drive, bimanual
- Type 5 Non-powered single-sided drive
- Type 6 Non-powered foot propulsion
- Type 7 Attendant controlled — powered
- Type 8 Electromotor for drive, manual steering
- Type 9 Electromotor for drive, power steering
- Type 0 Others

5 SHAPE AND DIMENSIONS

The typical shape of wheelchair is shown in Fig. 1. The overall dimensions shall be a given in Table 1.

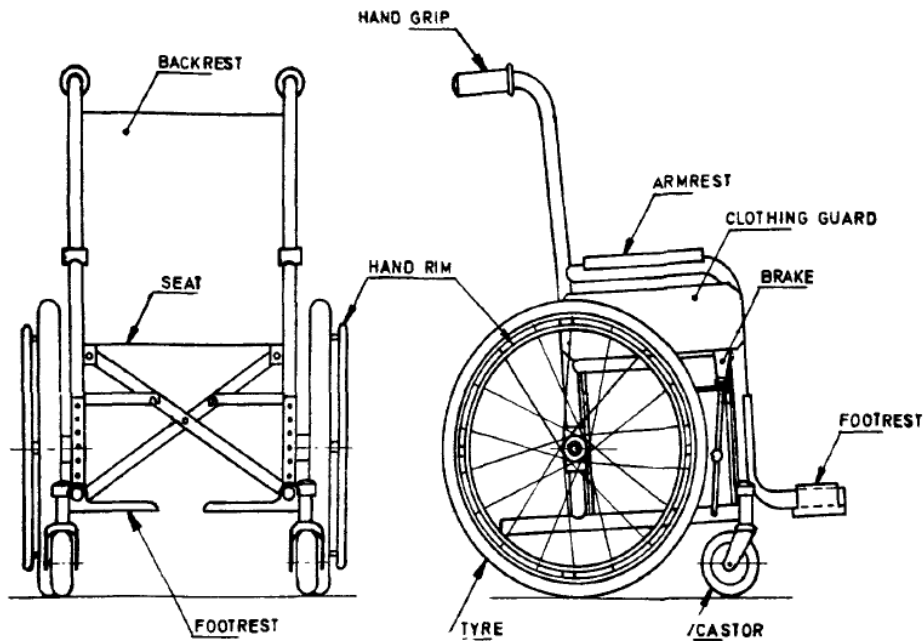

FIG. 1 WHEELCHAIR, FOLDING, JUNIOR SIZE

Table 1 Overall Dimensions of Wheelchairs

Dimension	Size, mm
(1)	(2)
Overall length	750-800
Overall width, open	580-610
Overall width, folded	300-330
Overall height	860-900
Seat height from floor at the front	420-450
Slope of the seat	1 – 3°
Armrest height from seat	180-190
Seat width	360-370
Seat depth	320-340
Distance between seat and footrest	280, <i>Max</i>
Clearance of frame from floor	90, <i>Min</i>
Clearance of foot rest from floor	130, <i>Min</i>
Wheel diameter	451(20")
Weight of the wheelchair (basic model)	20 kg, <i>Max</i>

6 MATERIALS

6.0 General

The following materials shall be used in the manufacture of wheelchairs. Alternate materials which are equivalent in performance may also be used.

6.1 Frame

The frame shall be made of tubing of ERW/ CEW quality conforming to IS:3074 or IS:2039.

6.2 Clothing Guards

The clothing guards shall be of aluminium alloy or mild steel sheets, each of thickness 1.00 mm, Grade CR1 conforming to IS:513 . Alternatively, suitable grade of rigid plastic of minimum 3 mm thickness may be used.

6.3 Seat and Backrest

6.3.1 The seat and backrest shall be fabricated from cotton duck of suitable variety.

6.3.2 A suitable Vinyl Coated or Polyester fabric shall be used for covering the Seat and Backrest, The fabric should be non-toxic, non-allergic.

6.4 Armrests

6.4.1 The armrests shall be of timber (seasoned heartwood) with foam padding or integral polyurethane with Metal insert. The quality and treatment of timber shall be in accordance with the relevant Indian Standards.

6.5 Footrests

The footrests may be of die cast aluminium or of plastic with corrugated surface, mild steel sheet Grade CR1 conforming to IS:513 or tubular structure not less than 125 mm across the feet, as desired by the purchaser. If specially required for paraplegics, footrest may be supplied to suit the length of the foot of the patient ensuring that the foot does not project out.

6.6 Castors

The solid tyres used in castors shall be made of non-marking resilient rubber . or Ethylene Vinyl Acetate (EVA) or Thermoplastic Polyurethane (TPU) with minimum hardness of 60 Shore 'A' .

6.7 Rear Wheels

6.7.1 The rear wheels shall be of 451 (20") size and shall have rims, tyres, tubes, nipples, spokes and washers conforming to the relevant Indian Standard. The solid tyres shall be made of non-marking resilient rubber or Ethylene Vinyl Acetate (EVA) or Thermoplastic Polyurethane (TPU) with a minimum hardness of 60 shore 'A' .

NOTE – In Type 1 wheelchairs, the rear wheels could be as small as the front wheels.

6.7.2 The wheels shall be firmly secured to the frame with the help of low carbon steel axles of minimum 11.5 mm diameter, heat treated to 30 HRC, Minimum. The hardness shall be tested in accordance with IS 1586 (Part 1).

6.7.3 The hub shall have two cups/cones or ball bearings for smooth and silent operation.

6.8 Hand Rims

6.8.1 The hand rims shall be fabricated from steel/aluminium tubing with minimum outside diameter 17 mm.

NOTE – Hand rims are not required for Type 1 wheelchairs.

6.9 Folding Mechanism

The folding mechanism shall be of suitable tubular or mild steel flat structure.

7 REQUIREMENTS

7.1 Backrest and Seat

7.1.1 The backrest shall be firmly secured to the vertical side members and shall be removable. The seat shall be firmly secured to each side of the frame. The backrest shall start just above the seat top.

7.1.2 The construction of the seat and the backrest shall be of non-rigid type and such that the cotton duck takes the load instead of the cover. The attachment shall be at a minimum of five places on each side through the steel strip inserts.

7.2 Frame

The wheelchair frame shall be of welded construction. The various members by themselves shall each be of single piece without any joint. The rear vertical members shall be bent and sealed at the top to accommodate plastic handgrips for pushing the chair by an attendant. All open ends of tubular construction must be sealed with end plugs (metallic or plastic).

7.3 Footrests and Supports

7.3.1 The surface of the footrest shall be non-slip.

7.3.2 The footrest shall be capable of swinging about its own axis so that when a patient enters or leaves the chair, the footrest shall clear the way without causing any obstruction in this raised position, the footrest shall be at an angle of 90° to 120° to its normal horizontal position.

7.3.3 The footrest swing shall be controlled with a spring and it shall stay in the raised position.

7.3.4 The swinging detachable type of footrest shall be free from sticking of the pin in the spring lock.

7.3.5 The footrest shall be detachable by the user himself but shall be incapable of coming out inadvertently

7.3.6 In case of adjustable footrest, the distance between the footrest and the seat shall be capable of adjustment (namely, telescopic adjustment) through not less than 40 mm in minimum four steps. The locking mechanism for each step shall be such that once locked, it will not permit the footrest being pushed down under the weight of the patient.

7.3.7 A belt of minimum 50 mm width shall be provided at leg rest level to restrict the leg from falling backward while in use, It shall be firmly secured to the wheelchair such that the fastening does not fail with the weight of the legs.

7.3.8 The footrest supports shall be of robust construction and shall be capable of swinging clear of the entrance passage of the patient.

7.3.9 Footrest for different categories of patients are as given below:

- a) Fixed platform type;
- b) Platform type with height adjustment;
- c) Swinging without height adjustment; and
- d) Swinging with height adjustment.

7.4 Armrests

Armrest shall be tilted to each side of the chair and shall be of such a height and shape as to provide adequate security and prevent the patient from falling sideways out of the chair in case of detachable armrest, it shall be detachable by the user himself but shall be incapable of coming out inadvertently. The fitting of the armrest to the frame shall be rigid and non-shaky to avoid any accident

7.5 Hand Rims

The ends of the tubings shall be joined by welding. The fixation of hand rim to wheel rim (minimum four places) shall be such that it does not obstruct/injure the fingers while driving. The surface of hand rims shall be smooth in all respects.

7.6 Brakes

Two individual parking brakes (push/pull type), one on each wheel, shall be provided on wheelchairs. The brakes shall be capable of being locked in final position and shall be easy and compatible in operation. They shall not be loose to result into accidental locking in use.

7.7 Castors

7.7.1The wheelchair shall have two castors which shall be able to swivel through 360° in both directions, firmly secured to the frame in the front with either of the following combinations of bearings for smooth and silent performance:

- a) Two ball/thrust bearings, or
- b) One ball/thrust bearing and a pair of swivelling bush bearings.

7.7.1.1 The stem shall be of minimum 75 mm length

7.7.2 The hub of wheel shall have either self-contained ball bearings or needle bearings or sintered bronze/brass bushes or nylon bushes.

7.7.3 The tyre shall be not less than 125 mm in diameter with wheel tread of minimum 20 mm. The tyre shall be Snap-on type. It shall not roll on the wheel under a load of 50 kg.

7.7.4 The castor shall have a load rating of 25 kg, *Min.*

7.8 Wheels

The wheels shall be fixed to the frame in such a manner that the fitting shall be rugged enough to withstand the shocks during normal use. The wheels shall not rotate in more than one plane when the chair loaded with 50 kg is propelled. The wheels shall be removable from the chair without disturbing the bearing assembly.

7.9 Clothing Guards

Clothing guards shall be securely attached in between the front and the rear vertical members of the chair (*see* Fig. 1). The clothing guards shall have single or double hemmed/beaded edges for mild steel guards and single hemmed/ beaded edges for aluminium guards to eliminate possibility of sharp projections which might catch and tear the clothing. The guards shall be sufficiently rigid and shall have a smooth surface

7.10 Folding Mechanism

The folding mechanism shall not in any way affect the rigidity of the chair in the unfolded condition. The folding mechanism shall be flexible enough to keep all the four wheels on ground with ± 20 mm variation under one wheel. It shall permit folding of the chair with ease and without any jamming of the various cross pieces.

7.11 Lubrication

Suitable provision shall be made to lubricate the various moving parts of the chair. The manufacturer shall provide complete information for the type of lubricant to be used and instructions for proper lubrication of the moving parts of the chair.

8 FINISH

8.1 Materials and finishes shall be non-toxic.

8.2 All exposed metallic parts shall be stove enamelled (after primary coat) or powder coated or plated as agreed to between the purchaser and the supplier. The resulting finish shall be hard and shall not readily chip or flake.

8.2.1 When plated, the plating on the mild steel components shall conform to Service Grade No. 2 of IS 1068.

8.2.2 All aluminium components shall be anodized or buffed clean in case of die casted components. The anodizing of aluminium components shall conform to Grade AC 10 of IS 1868.

8.3 Welding shall fully penetrate and shall be sound in every respect. It shall be finished smooth and there shall be no exposed sharp edges in the framework or other unsealed formations which may harbour dust. All exterior surfaces shall be free from defects and protrusions to avoid hurting the patient or tearing his clothing.

9 TESTS

9.1 Test for Wheeling

The chair shall be subjected to a load of 50 kg. The chair shall be wheeled around on an even floor. The chair shall move smoothly and straight without any wobbling, rocking or rattling.

9.2 Hazard Running Test

9.2.1 The effect of this test is to subject the framework of the wheelchair to simulated conditions similar to the worst conditions ever likely to be met in use.

9.2.2 A uniformly distributed test load of 75 kg shall be applied on the frame members which normally carry the seat. Under this load, the wheelchair shall negotiate at least once in every metre of travel at 1.6 km/h, a hazard having a vertical drop of 10 mm.

9.2.3 This test of three hours uninterrupted duration shall not result in any deleterious effect on the chair, such as, failure of joints or welds, breaking or flaking of enamel, wobbling and rattling.

9.2.4 Measurements of the height above floor level of the top of the seat support members and the width between the arms, taken above the centre of the seat, shall be recorded both before and after the test. No change in dimensions shall be permitted. The change in height dimensions of the seat support members shall be adjusted to account for tyre wear resulting from the test which shall be computed from actual measurements of the wheel diameter taken before and after the test.

9.2.5 For the purpose of the above test, the chair may be mobile and mechanically pushed at points on the handle corresponding roughly to the position at which an attendant's hands would be placed while wheeling the chair. Alternatively, the chair may be anchored to a stationary pillar at these points on the handle and the wheels made to contact an oscillating platform (running on rails) or a rotating drum to which the hazards are fixed.

9.3 Load Test

A load of 50 kg shall be applied gradually at the middle of the armrest while preventing the chair from toppling over. The load shall be maintained for 5 minutes. The wheelchair shall not be damaged after the test. The test shall be repeated on the other armrest also.

9.4 Test for Folding

The wheelchair shall be folded and unfolded 250 times consecutively on a smooth floor. The chair shall open and close without undue exertion and it shall not suffer any damage during the test. The chair shall roll easily in the folded position. Prior to test, parts requiring lubrication shall be properly lubricated.

10 ATTACHMENTS AND ACCESSORIES

Various accessories are required to cater to the needs of different categories of patients. All the attachments incorporating such accessories shall be provided with the basic model and shall in no way become obstruction for its coverage under the Indian Standard. These accessories are optional and include the following:

- a) Heel loops,
- b) Toe straps,
- c) Calf pads,
- d) Crutch holder,
- e) Desk type armrest tray,
- f) Pegs on hand rims, and
- g) Drip set attachments

11 MARKING

11.1 BIS Certification Marking

The product(s) conforming to the requirements of this standard may be certified as per the conformity assessment schemes under the provisions of the Bureau of Indian Standards Act, 2016 and the Rules and Regulations framed there under, and the product(s) may be marked with the Standard Mark.

11.2 Each wheelchair shall have a label suitably marked with the indication of the source of manufacture and the type of chair (*see* 4.1).

11.3 Each wheelchair shall be marked with a clearly visible sign shown in Fig. 2 to caution others on the road.



FIG. 2 SIGN OF CAUTION

12 PACKING

Packing of junior size folding wheelchair shall be done as agreed to between the purchaser and the supplier.