

**BUREAU OF INDIAN STANDARDS**  
**DRAFT FOR COMMENTS ONLY**  
*(Not to be reproduced without permission of BIS  
or used as an Indian Standard)*

*भारतीय मानक मसौदा*  
*ठोस जैव ईंधन – नमूनाकरण*

*Draft Indian Standard*  
**SOLID BIOFUELS — SAMPLING**  
(ICS 27.190; 75.160.40)

---

Solid Mineral Fuels and Solid Biofuels Sectional  
Committee, PCD 07

Last date for Comments:  
**9 June 2024**

---

**FOREWORD**

*(Formal clauses will be added later)*

Solid Biofuels is one of the emerging sustainable energy source. Solid biofuels may contribute significantly to mitigating greenhouse gas emissions and reducing dependence on solid mineral fuels. Thus, standardization in the area of solid biofuels is essential for the production, trade and utilization of solid biofuels.

This standard prescribes the principles for sampling solid biofuels. It also aims to serve as a tool to enable efficient trading of biofuels and a good understanding between seller and buyer, as well as a tool for communication with equipment manufacturers.

While preparing this standard, considerable assistance has been derived from ISO 18135. Since biomass available in India is of different variety, therefore few examples stated in the standard have been modified and reference of BioNorm project has been deleted when compared with ISO 18135. All other content is same as mentioned in ISO 18135.

Data referred in Annex D of this standard have been obtained by validation investigation, that is taking into consideration of BioNorm projects. For reference of the data stated, Annex F of ISO 18135 may be referred.

In reporting the result of a test or analysis made in accordance with this standard, if the final value, observed or calculated, is to be rounded off, it shall be done in accordance with IS 2 : 2022 'Rules for rounding off numerical values (*second revision*)'.

## **1 Scope**

**1.1** This standard prescribes methods for preparing, sampling plans and certificates, as well as taking samples of solid biofuels, for example, from the place where the raw materials grow, from production plant, from deliveries for example lorry loads or from stock. It includes both manual and mechanical methods and is applicable to solid biofuels that are either:

- a) fine (particle sizes up to about 10 mm) and regularly shaped particulate materials that can be sampled using a scoop or pipe, for example, sawdust, olive stones, wood pellets and threshing machine or thresher waste fine (particle size up to about 10 mm);
- b) coarse or irregularly shaped particulate materials (particle sizes up to about 200 mm) that can be sampled using a fork or shovel, for example, wood chips and nut shells, forest residue chips, straw, stalk, agro residues and post-harvest waste;
- c) baled materials, for example, baled straw, grass, stalks or leaves;
- d) large pieces (particle sizes above 200 mm) that are either picked manually or automatically;
- e) vegetable waste, fibrous waste from virgin pulp production and from production of paper from pulp that has been dewatered;
- f) thermally treated and densified biomass materials; and
- g) roundwood, sawmill or lumber mill waste, wood strips and wood pieces.

**1.2** This standard is not applicable to airborne dust from solid biofuels. It may be possible to use this standard for other solid biofuels.

**1.3** The methods described in this standard may be used, for example, when the samples are to be tested for moisture content, ash content, calorific value, bulk density, durability, particle size distribution, ash melting behavior and chemical composition.

## **2 REFERENCES**

The standards listed below contain provisions which through reference in this text, constitute provisions of the standard. At the time of publication, the editions indicated were valid. All standards are subject to revision, and parties to agreements based on these standards are encouraged to investigate the possibility of applying the most recent editions of the standards listed below.

| <i>IS No./ Other Publication</i>                 | <i>Title</i>  |
|--|---|
| IS 16143 (Part 2) : 2021 /<br>ISO 13909-2 : 2016 | Hard Coal and Coke - Mechanical Sampling : Part 2 Coal Sampling from Moving Streams ( <i>first revision</i> ) |
| IS 16143 (Part 8) : 2021 /<br>ISO 13909-8 : 2016 | Hard coal and coke — Mechanical sampling Part 8 Methods of testing for bias ( <i>first revision</i> )         |
| ISO 21398 : 2019                                 | Hard coal and coke — Guidance to the inspection of mechanical sampling systems                                |
| PCD/07/20276                                     | Solid biofuels — Sample preparation   |
| PCD/07/19505                                     | Solid biofuels — Vocabulary   |

## **3 TERMINOLOGY**

For the purpose of this standard, definitions given in PCD/07/19505 and the following shall apply.

**3.1 Bias** — Systematic error that leads to the average value of a series of results being persistently higher or persistently lower than those that are obtained using a reference sampling method.

**3.2 Large Stockpile** — Stockpile with a capacity greater than 40 tonne.

**3.3 Nominal Top Size** — aperture size of the sieve through which at least 95 percent by mass of the material passes.

NOTE — For pellets the diameter is used to determine the nominal top size.

**3.4 Overall Precision** — closeness of agreement between independent test results obtained under stipulated conditions; including sample preparation and sample analysis.

NOTE — A determination might be made with great precision and the standard deviation of a number of determinations on the same sub-lot might, therefore, be low; but such results are accurate only if they are free from bias.

## **4 PRINCIPLE**

The main principle of correct sampling is to obtain a representative sample (samples) from the whole lot concerned. Every particle in the lot or sub-lot to be represented by the sample should have an equal probability of being included in the sample. In order to do so, a sampling plan is needed. Fig. 1 shows the actions needed for the development of a sampling plan. When sampling is to be carried out according to the same plan repeatedly or continuously (for example, daily), a full sampling plan shall be prepared according to **5.2** (it is necessary to do this only once). A brief sampling plan shall be prepared for routine use according to **5.3** (same type of sampling object or situation occasionally). In the case of a new material or supplier, the existing plan shall be checked and updated or a new full sampling plan shall be developed.

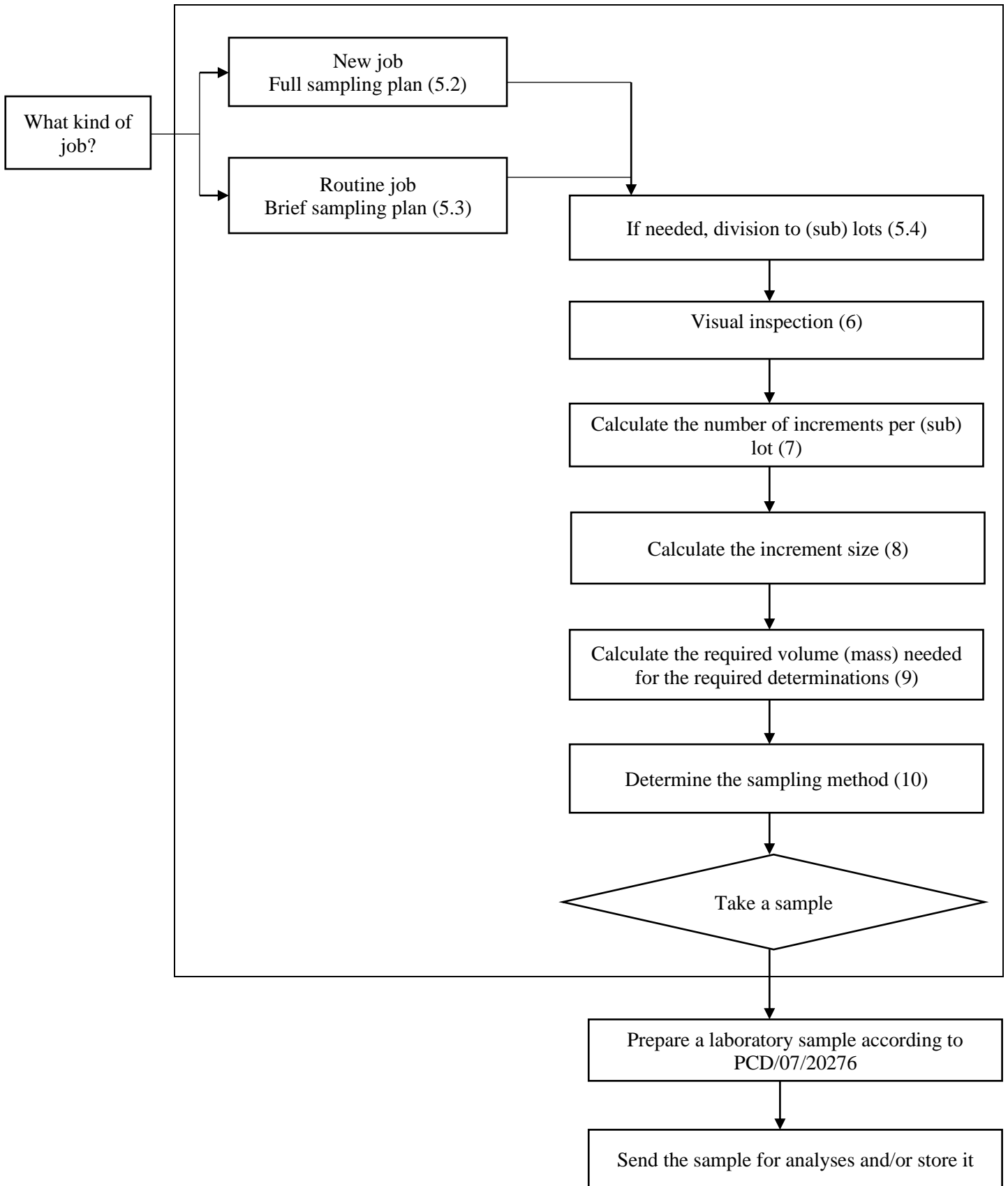

FIG. 1 PROCEDURE FOR SAMPLING

## **5 ESTABLISHING A SAMPLING SCHEME (SAMPLING PLAN)**

### **5.1 Principle**

The sampler shall prepare a full sampling plan either by copying the forms presented in Annex A or by preparing his own forms or documents containing the appropriate items selected from those shown in Annex A. Each sampling plan shall be given a unique reference number or a code/name.

### **5.2 Full Sampling Plan**

A model sampling plan is presented in Annex A as forms that are to be completed by the sampler. Once completed, these forms become sampling certificates.

### **5.3 Brief Sampling Plan**

The sampling plan shall include the following key elements:

- a) Reference to the full sampling plan (Annex A);
- b) Unique identification number of the sample;
- c) Date and time of sampling;
- d) Identity of the biofuel supplier;
- e) Identification number of the lot or the sub-lot;
- f) Type of biofuel (wood pellet, briquette, chips, etc.).

Also consider including the following items:

- g) Name of the sampler;
- h) Mass or volume of the sub-lot or the lot;
- i) Identity of the carrier (transport company);
- j) Storage information of the lot (like weather conditions, storage inside or outside);
- k) Sampling technique (for example, shoveling, cross stream cutter, hammer sampler, probe, stopped belt, etc.);
- l) Any other details that change from sample to sample;
- m) Source (pile, silo, cargo hold, train car, truck/lorry, etc.) and location (centre, bottom, etc.) where the sample was obtained.

### **5.4 Division of Lots**

The lot may be sampled as a whole, resulting in one sample or divided into a number of sub-lots resulting in a possible sample from each. In the case of manual sampling a lot may be sampled as a whole only when it has a maximum of 2500 tonne or as a series of sub-lots each to a maximum of 2500 tonne. For example, fuel dispatched or delivered over a period of time, a ship load, a train load, a wagon load, or fuel produced during a certain period for example, a shift.

Such division into a number of sub-lots can be necessary to

- a) Achieve the required precision (calculated by the procedure in **7.2**);
- b) Maintain the integrity of the sample by enclosing in an airtight plastic bag or container, for example, avoiding bias that can result from the loss of moisture due to standing or

changing of calorific value caused by biological activity;

- c) Create convenience when sampling lots over a long period, for example, on a shift basis;
- d) Keep sample masses manageable, taking into account the maximum lifting capacity;
- e) Distinguish different components of a mixture of fuels, for example different biofuel types within one lot; and
- f) Be consistent in sampling from several specified locations of the lot to avoid bias from particle segregation during loading.

In the case of mechanical sampling, for example from large shipments, the maximum sub-lot size should be decided by the parties involved. For example, a maximum 5000 tonne sub-lot is advisable.

#### *Example*

- a) Consider a power station that receives 140 lorry-loads of wood chips a month totaling 3 500 tonne. In this example, four sub-lots can be manually sampled where a sub-lot could be the quantity of fuel delivered in a week (about 35 lorry-loads).
- b) Consider a single shipment of 46 000 tonne of wood pellets. In this example, 10 sub-lots of 4 600 tonne each can be mechanically sampled or 19 sub-lot samples, each representing 2 421 tonne, would need to be taken manually.

## **6 VISUAL INSPECTION**

Visual inspection shall be used for the choice or verification of the classification of the solid biofuels. Based on the sampling plan, verification or selection of the sampling equipment and the sampling method shall also be made by visual inspection. If the biofuel consists of a mixture of substantially different materials, or if it contains impurities (such as soil or pieces of metal, sand, construction debris, stones and plastic), this shall be reported in the sampling certificate. If the biofuel type or its quality is diverging strongly from the one expected, the sampler shall report without any delay to the appropriate party for further instructions.

NOTE — Photographs of deviation noted during visual inspection can assist with documentation.

## **7 NUMBER OF INCREMENTS**

### **7.1 General**

In all methods of sampling, sampling preparation and analysis, errors are incurred, and the experimental results obtained from such methods for any given parameter deviate from the true value of that parameter. As the true value cannot be known exactly, it is not possible to assess the accuracy of the experimental results that is the closeness with which they agree with the true value. However, it is possible to make an estimate of the precision of the experimental results that is the closeness with which the results of a series of experiments made on the same fuel, agree among themselves.

It is possible to design a sampling scheme that, in principle, can achieve a desired level of precision with a material determined lower limit.

Precision is the closeness of agreement between the results obtained by applying the experimental procedure several times under prescribed conditions and is a characteristic of the sampling scheme used and the variability of the biofuel being sampled. The smaller the random errors of the scheme, the more precise the scheme is. A commonly accepted index of

precision is two times the sample estimate of the population standard deviation, and this index of precision is used throughout this document.

If a large number of replicate samples are taken from a sub-lot of biofuel, prepared and analyzed separately, the precision of a single observation,  $P$ , is calculated as:

$$P = 2s = 2\sqrt{V_{SPT}} \quad \text{----- (1)}$$

where

$s$  = the sample estimate of the population standard deviation;

$V_{SPT}$  = the total variance of the results for replicate samples.

$V_{SPT}$  is calculated as:

$$V_{SPT} = \frac{V_i}{n \times N_{SL}} + \frac{V_{PT}}{N_{SL}} \quad \text{----- (2)}$$

The final overall precision,  $P_L$ , for the total quantity of biofuel is calculated as:

$$P_L = 2\sqrt{\frac{V_i}{n \times N_{SL}} + \frac{V_{PT}}{N_{SL}}} \quad \text{----- (3)}$$

where

$P_L$  = the overall precision for the sampling, sample preparation and testing for the whole biofuel lot at 95 percent confidence level;

$V_i$  = the primary increment variance;

$n$  = the number of increments per (sub-) lot;

$N_{SL}$  = the number of sub-lots in the lot; and

$V_{PT}$  = the sample preparation and testing variance.

In the case where the total quantity of biofuel is divided into sub-lots, all sub-lots shall be sampled. The number of sub-lots can be 1.

## 7.2 Primary Increment Variance ( $V_i$ )

The primary increment variance,  $V_i$ , depends upon the type and nominal top size of the fuel, the degree of pre-treatment and mixing, the absolute value of the parameter to be determined and the mass of increment taken. In general, the increment variance ( $V_i$ ) is different for the different parameters (in the same material) in practice. The calculation of the minimum number of increments should be based on different numbers of  $V_i$ ,  $V_{PT}$  and  $P_L$  for each of the required parameters and the highest minimum number of increments should be selected (*see also 7.5* for the calculation of minimum number of increments).

The value of the primary increment variance,  $V_i$ , required for the calculation of the minimum number of increments using equation (1) or precision using equation (3) can be obtained by one of the following methods:

- a) Determining it directly on the biofuel to be sampled by taking at least 30

increments spread over an entire lot of the same type of fuel and analyzing each increment separately on the required parameters, preferably ash (dry basis) and total moisture.

$$V_i = \frac{1}{n-1} \left[ \sum x_i^2 - \frac{(\sum x_i)^2}{n} \right] - V_{PT} \text{ ----- (4)}$$

where

$x_i$  = the value of the analyzed parameter.

See E-3 for an example in determining the  $V_i$ .

b) Assuming values of  $V_i$  from similar materials or from previous characterization experience with similar fuel handling and sample preparation. The assumptions should preferably be verified afterwards if possible.

c) Assuming values of  $V_i$  as listed in Annex D for the same type of materials. The assumptions should preferably be verified afterwards if possible.

### 7.3 Preparation and Testing Variance ( $V_{PT}$ )

The value of the sample preparation and testing variance,  $V_{PT}$ , required for the calculation of the minimum number of increments using equation (6) or precision using equation (3) can be obtained by one of the following:

a) Determining it directly on the fuel to be sampled by constituting at least 20 sub-samples spread over the entire lot of the same type of fuel. Each sub-sample is divided into two parts (constituting a pair) and prepared so that split portions of each sub-sample are taken at the first division stage. Each portion shall be prepared and tested for the parameters of interest, preferably ash (dry basis) and total moisture. The same analytical methods are applied as are used in routine operations. The difference between the two results shall be calculated for each pair and the preparation and testing variance,  $V_{PT}$ , can be calculated as follows:

$$V_{PT} = \frac{\sum d_i^2}{2n_p} \text{ ----- (5)}$$

where

$d_i$  = difference between individual pair members; and

$n_p$  = number of pairs.

b) Assuming values of  $V_{PT}$  from similar materials or from previous characterization experience with similar fuel handling and sample preparation. The assumptions should preferably be verified afterwards if possible.

c) Assuming values of  $V_{PT}$  listed in Annex D for the same type of materials. The assumptions should preferably be verified afterwards if possible.

### 7.4 Overall Precision ( $P_L$ )

The required overall precision for each relevant parameter on a lot should be agreed upon between parties concerned. In the absence of such an agreement, the values given in Table 3



to Table 12 may be assumed. By keeping track of the results of the analyses, changes in the composition over time can be identified, which could be an indication to re-evaluate  $V_i$  and  $V_{PT}$ . This is to be done using **7.2** and **7.3**.

### 7.5 Calculation of Number of Increments Per (Sub-) Lot

Determine the number of sub-lots required for practical reasons and then estimate the number of increments for a desired overall precision by transposing equation 6 (rounded up):

$$n_{min} = \frac{4V_i}{N_{SL}P_L^2 - 4V_{PT}} \text{ ----- (6)}$$

where

$N_{SL}$  = number of sub-lots in the lot; when the lot is not divided,  $N_{SL} = 1$ ;

$n_{min}$  = number of increments (minimum) per sub-lot, or per lot if the lot is not divided into sub-lots; ( $N = 1$ ) if calculated, if  $n_{min}$  is less than 10, it shall be set to  $n_{min} = 10$  unless agreed upon otherwise;

$V_i$  = primary increment variance;

$P_L$  = overall precision for the sampling, sample preparation and testing for the whole biofuel lot at 95 percent confidence level;

$V_{PT}$  = preparation and testing variance.

NOTE — Equation (3) is rewritten to yield equation (6).

Parties can agree on a different minimum number of increments; this can also be below 10. Parties should be aware of the possibility that extracting increments of extreme content will influence the final measured value. This is especially possible for materials that segregate where fines concentrate at certain regions of the bulk such as the center.

Examples utilizing this formula are given in **E-3**.

A calculated value of  $n_{min}$  of infinity or a negative number indicates that the errors of preparation and testing are such that the required precision cannot be achieved with this number of sub-lots. In such cases, or if  $n_{min}$  is impracticably large, reduce the errors of sample preparation and testing, by agreeing on a higher overall precision, or increase the number of sub-lots by one of the following means.

- a) Choose a new number of sub-lots corresponding to a convenient sub-lot mass, recalculate  $n_{min}$  from equation (6) and repeat this process until  $n_{min}$  is a practicable number.
- b) Decide on the maximum practicable number of increments per sub-lot,  $n_{mp}$ , and calculate  $N_{SL}$  according to equation (7):

$$N_{SL} = \frac{4(V_i + n_{mp}V_{PT})}{n_{mp}P_L^2} \text{ ----- (7)}$$

Adjust  $N_{SL}$  upwards if necessary to a convenient number and recalculate  $n_{min}$ . A calculation example is found in **E-3**.

As described in **7.1** to **7.3**, the tables in Annex D show reference or default values for  $V_i$  and

$V_{PT}$  when no other information is available. Table 3 to Table 12 show reference values for  $V_i$  and  $V_{PT}$  when no other information is available. It is recommended to measure the  $V_i$  and  $V_{PT}$  per type, group and/or supplier of biofuel.

The required overall precision on a lot should be agreed between the parties concerned. In the absence of such agreement, the values given in Table 3 to Table 12 may be assumed. By keeping track of the results of the analyses, changes in the composition over time can be identified, which could be an indication to (re-)evaluate  $V_i$  and  $V_{PT}$ .

For small storages in cellars, silos or bunkers which are difficult to enter and to take samples the number of increment is reduced (Annex D is not applicable for small storages). The variance for the different parameters shall be calculated according to **7.2** and individually stated.

## **8 CALCULATION OF THE SIZE OF INCREMENT**

The minimum volume of the increment shall be:

$$V_{\text{incr}} = 0.5 \quad \text{for } d_{95} < 10 \quad \text{----- (8)}$$

$$V_{\text{incr}} = 0.05 \times d_{95} \quad \text{for } d_{95} \geq 10 \quad \text{----- (9)}$$

where

$V_{\text{incr}}$  = minimum volume of the increment, in l;

$d_{95}$  = nominal top size, in mm.

The sampler shall estimate and record the appropriate sampling tool. Ensure that samples are large enough for analyses.

## **9 COMBINED SAMPLE — CALCULATION OF THE VOLUME OF THE COMBINED SAMPLE**

The sampler shall refer to **7.5** for the minimum number of increments,  $n_{\text{min}}$ , and the minimum volume of the individual increments,  $V_{\text{incr}}$ , according to **8** for the circumstances covered by the sampling plan.

The sampler shall consider the tests which have to be done and calculate the required volume (mass) needed for the required determinations ( $V_{\text{req}}$ ). In particular, the calculation shall take into account the need in some test methods for duplicate test portions, and for extra material to be available in case dubious results are obtained.

The calculated volume of the combined sample shall be of such a size that sufficient material is provided for all the tests to be performed, that is  $V_{\text{Combined Sample}}$  greater than  $V_{\text{req}}$ . Therefore, the minimum sample volume should be estimated from the sampling plan. If the calculated volume is too small, the size or the number of increments shall be increased. When the increments are reduced in volume before they are added to the combined sample, the volume,  $V_{\text{incr}}$  used in this calculation shall be the volume obtained after the reduction. The minimum

increment volumes of **8** should be used.

The sampler shall calculate the volume,  $V_{\text{Combined Sample}}$  for the combined sample:

$$V_{\text{Combined Sample}} = n_{\text{min}} \times V_{\text{incr}} \text{ ----- (10)}$$

where

|                              |  |
|------------------------------|--|
| $V_{\text{Combined Sample}}$ | = volume for the combined sample, in l;              |
| $n_{\text{min}}$             | = minimum number of increments;                      |
| $V_{\text{incr}}$            | = minimum volume of the individual increments, in l. |

Table 1 can be used to record the results of the calculation. Annex C gives typical bulk densities of biofuels.

## **10 SAMPLING EQUIPMENT**

### **10.1 General**

The equipment shall enable the sampler to take unbiased increments to provide a representative sample.

The opening of the sampling device should be at least 2.5 times the nominal top size and should be large enough for normal oversized material particles to enter the sampling device. The volume of the sampling device shall comply with the minimum required increment volume,  $V_{\text{incr}}$ , as described in **8**. The pellet diameter shall be considered as nominal top size for sampling and sample preparation and the opening of the equipment shall be large enough for the longest pellets to enter.

Sampling tools shall be robust, and be able to withstand physical force, wear and prolonged use without compromising functionality.

All moving parts should be accessible to inspection and maintenance.

It is recommended that mechanical sampling equipment and manual sampling procedures should be tested for bias after implementation, and this should be repeated with a frequency that reflects the consequences of a possible bias. Bias testing of mechanical sampling equipment can be done according to IS 16143 (Part 8), and manual sampling procedures according to the same principles.

The choice of sampling tool shall enable the sampler to extract the biofuel safely.

### **10.2 Equipment for Manual Sampling**

#### **10.2.1 *Sampling Box for Falling-stream***

The sampling box shall have a square or rectangular opening at the top. The opening  $W$  of the top of the sampling box shall be at least 2.5 times the nominal top size and should be large enough for normal oversized material particles to enter the sampling device. The dimensions of the top opening of the sampling box shall be large enough so that the box

cuts the whole of the stream to be sampled. The height of the sampling box shall be large enough to ensure that the box does not become full during sampling of the increment. The sampling box shall be provided with a handle or some other means of support (for instance mounted on rails) that enables the sampler to pass the box safely through the whole cross section of the falling stream of the biofuel to be sampled. Fig. 2 shows an example of a sampling box.

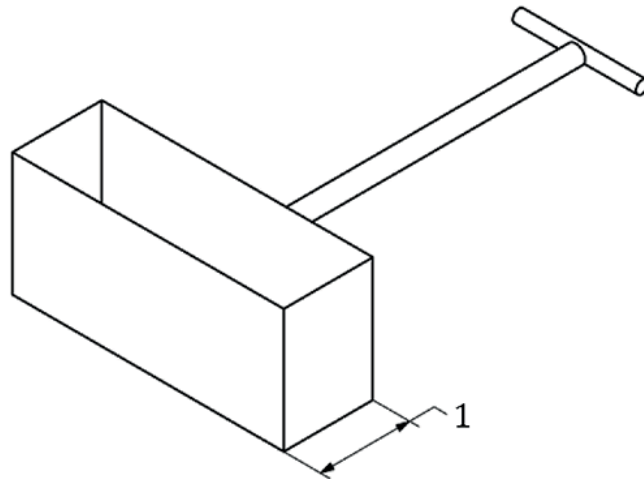

FIG 2. EXAMPLE OF A SAMPLING BOX

where

1 = width of the sampling box

For biofuel with large particle size, or high material flows, sampling boxes might become too big and heavy for manual sampling and mechanical sampling is recommended.

### 10.2.2 Scoops

A scoop can be designed as illustrated in Fig. 3, complying with the general requirements for equipment design.

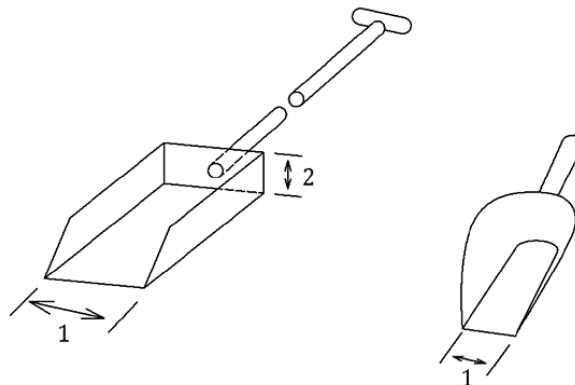

FIG. 3 EXAMPLES OF SCOOPS

where

1 = width  
2 = height

The width and the height of the scoop should be greater than 2.5 times nominal top size and should be wide enough for normal oversized material particles to enter the sampling device.

NOTE — A scoop is best for sampling from a stationary pile.

### 10.2.3 Shovels

A shovel can be designed as illustrated in Fig. 4, complying with the general requirements for equipment design.

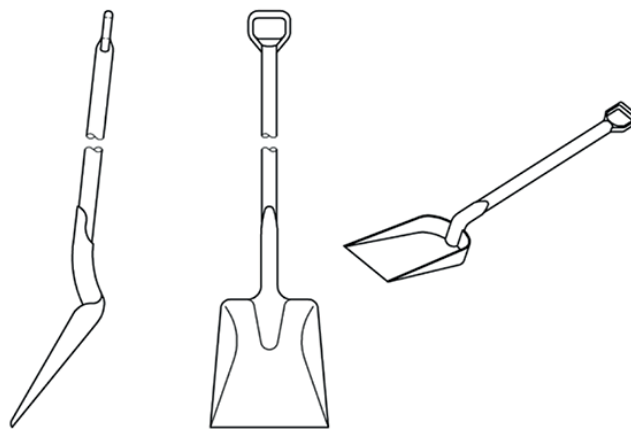

FIG. 4 EXAMPLE OF A SHOVEL

NOTE — A shovel is best for sampling from a stationary pile with coarse biomass ejected from a truck.

### 10.2.4 Forks

When using a fork (*see* Fig. 5), the smaller particles of the material being sampled will fall between the tines of the fork. The sampler shall check that the fork to be used for sampling a material has tines sufficiently close together to minimize the amount of particles falling between them. Any material losses will affect the quality of the sample and may lead to a biased result.



FIG. 5 EXAMPLE OF A FORK

NOTE — A fork is best for sampling straw.

### 10.2.5 Grabs

Both an open-type grab and a closed-type grab may be used. Fig. 6 contains drawings of examples of a grab.

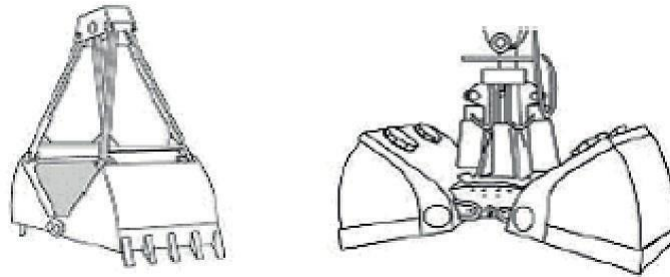

FIG. 6 EXAMPLES OF GRABS (OPEN AND CLOSED TYPE)

### 10.2.6 Probes (thieves)

An example of a probe is shown in Fig. 7. The probe shall be designed so that it can be opened at an arbitrary depth inside the material to be sampled and afterwards extracted without loss or gain of material. The opening of the probe when the inner cone is lifted shall be greater than 2.5 times nominal top size of the material to be sampled and should be large enough for normal oversized material to enter the sampling device.

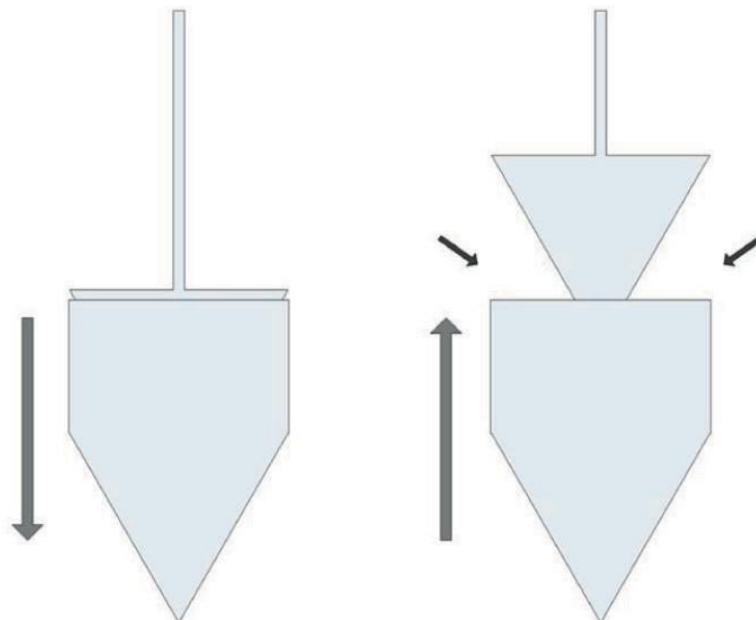

FIG. 7 EXAMPLE OF A PROBE

### 10.2.7 Pipes (Spears)

The holes in the sampling pipe should be positioned as illustrated in Fig. 8, and the pipe shall be constructed so that the holes open one after the other starting with the hole closest

to the tip of the pipe. A sampling pipe is suitable only for sampling free flowing granular and uniform materials. The length of the pipe shall be sufficient to reach all the way into the container or heap. The opening of the holes in the pipe shall be at least 2.5 times the nominal top size of the material to be sampled and should be large enough for normal oversized material to enter the sampling device.



FIG. 8 EXAMPLE OF A PIPE (SPEAR OR TRIER)

### 10.2.8 Frames

A sampling frame shall be used if increments are taken manually from a temporarily stopped conveyor. The sampling frame shall consist of two parallel metal plates with a distance between the two side plates of at least 2.5 times the nominal top size of the material to be sampled. The shape of the plates shall fit into the profile of the conveyor belt from which the sample is to be removed. The supports between the plates shall ensure a stable construction. A suitable tool shall be used to extract the material between the plates. Fig. 9 is a schematic drawing of a sampling frame placed on a stopped conveyor belt.

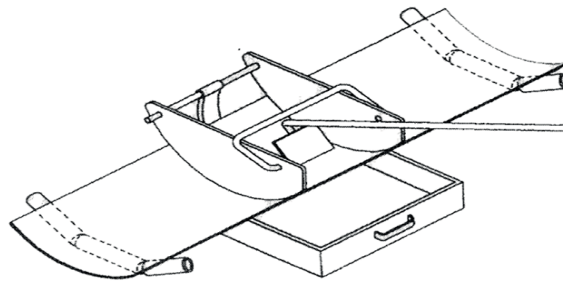

FIG. 9 FRAME

### 10.2.9 Hooks

For sampling baled straw-like material without taking apart the entire bale, a hook can be used (see Fig. 10). The hook shall be constructed with a barb, so that it can be pushed into the bale and extract a portion of straw when pulled back.

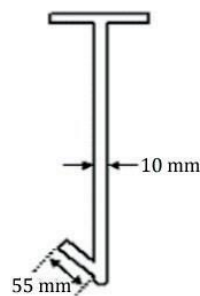

FIG. 10 HOOK

### 10.2.10 Drills (Augers)

A drill (see Fig. 11) can be manually or mechanically driven. For baled materials, the drill sampling can be driven by a brace or an electrical motor. The centre should be encapsulated to

prevent gaining or losing material that does not belong to the increment.

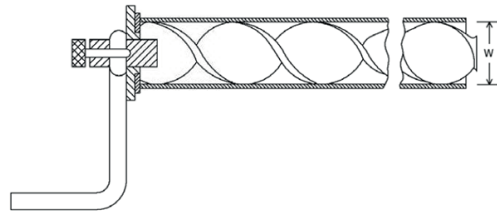

FIG. 11 DRILL

NOTE — The radius of the drill is the opening,  $W$ , of this sampling device.

### 10.3 Equipment for Mechanical Sampling

#### 10.3.1 Use of Coal Sampling Standards and Checking for Bias

With regard to mechanical sampling, sampling shall be carried out by systematic sampling either on a time-basis or on a mass-basis, or by stratified random sampling. A description of these methods and the necessary sampling intervals shall be described in IS 16143 (Part 2).

The consistency of loading of the belt should be controlled, as far as possible, so that sampling is as efficient as possible. The flow should be made reasonably uniform over the whole cross-section of the stream at all times by means of controlled loading or suitable devices such as feed hoppers, ploughs, etc.

In the coal standard, several actions have been included to minimize bias. It should be noted that biomass has (inconsistent) properties different to coal that could influence a uniform product stream such as the division of fine particles (dust) or clumping of biomass material. These properties should be considered when sampling from belts.

For auditors or certifiers, the mechanical sampling device shall be available for (visual and physical) inspection conforming with ISO 21398.

#### 10.3.2 Falling-stream Sampler

A falling stream sampler (cross stream cutter) (*see* Fig. 12) can be used for sampling materials that are free falling, for instance at the end of a conveyor belt. The device generally consists of a mechanically driven box, that moves at constant speed across (through) the falling material, with the opening (aperture) of the box at an angle as close to normal to the direction of the falling material as possible. The following design parameters shall be respected:

- a) cutter shall extract a complete cross section of the stream;
- b) cutter shall have parallel edges, ensuring even width of the cut across the stream;
- c) cutter shall move through the stream with constant velocity, avoiding slowing down as the cutter fills up;
- d) opening (aperture) of the cutter shall be minimum 2.5 times the nominal top particle size, to minimize the risk of blocking the flow into the cutter and should be large enough for normal oversized material to enter the sampling device;
- e) cutter shall not be filled more than two thirds at maximum conveyor load;
- f) cutter edges shall be robust and able to withstand the force of the falling material during prolonged use.



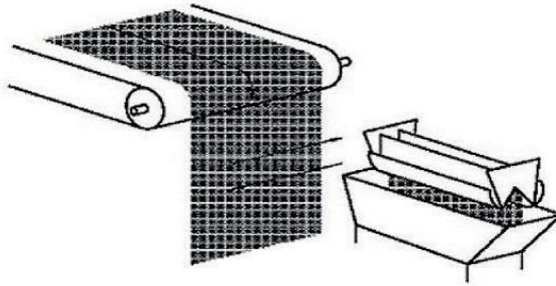

FIG. 12 FALLING-STREAM SAMPLER

### 10.3.3 *Cross-belt Sampler*

A cross-belt sampler (cutter) can be used for sampling materials from a moving conveyor belt. The equipment shall be designed so that it extracts a full cross cut of the material in the conveyor, it shall not only traverse over the full width of the belt, but it is important that the equipment extracts material all the way to the bottom of the belt. The sides (edges) of the cutter shall be parallel to ensure an even representation of all fractions of the flow.

The equipment shall be strong and durable, as it will retain the remaining flow of material while passing through the stream. For the same reason, normally no limitations are put on the speed of the cutter. However, it should not be too high either, as too much material will be pushed off the belt from the leading edges of the cutter. The following design parameters shall be respected:

- a) cutter edges (sides) shall be parallel;
- b) cutter shall take a complete cross-section of the stream; the cut shall have an equal width across the belt (a “slice” with equal thickness across the belt width);
- c) velocity of the cutter through the material shall be uniform; avoid slowing down the cutter when it passes through the material;
- d) aperture of the cutter shall be at least 2.5 times the nominal top size, to minimize the risk of blocking the flow into the cutter and should be large enough for normal oversized material to enter the sampling device;
- e) capacity of the cutter shall be sufficient to hold all material from passing the stream at maximum conveyor load;
- f) bottom of the cutter can be fitted with blades, brushes or skirts to avoid damaging the belt and ensure extraction of particles close to the bottom of the belt; these shall be inspected regularly and replaced when close contact to the belt can no longer be ensured;
- g) cross-belt sample should yield with a single motion an increment size equal or larger than the minimum increment volume; this is dependent on the belt speed and the amount of material on the belt.

An example of a cross-belt cutter is shown in Fig. 13, where the right-hand part illustrates the ideal extracted cut across the belt, with parallel sides.

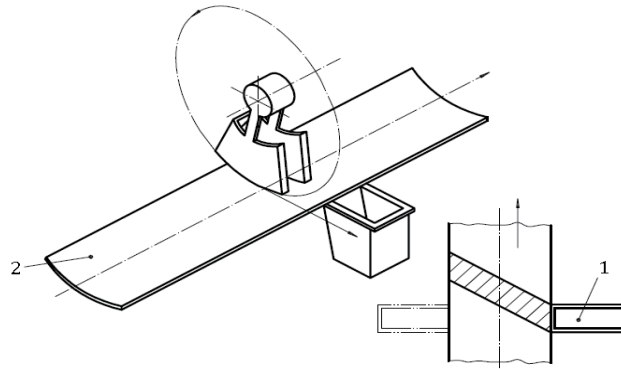

FIG. 13 EXAMPLE OF A CROSS-BELT SAMPLER

where

- 1 = cutter
- 2 = belt support to maintain curvature

Often, cross-belt samplers have difficulties extracting ideal increments, as especially fines are left at the bottom of the belt and material at the leading edges of the cutter, that should ideally be in the increment, is not extracted. In general, it is recommended to use falling stream cutters instead.

#### **10.3.4 Mechanical Probes**

The principle of a mechanical probe is similar to a manual probe (*see 10.2.6*), but driven by pneumatics or a motor. Often, mechanical probes are preferred, as it is difficult to manually drive a probe into a compact material.

#### **10.3.5 Mechanical Drills**

The principle of a mechanical drill is similar to a manual drill (*see 10.2.10*).

### **11 SAMPLING IN PRACTICE**

#### **11.1 General**

It is difficult to take samples in a way that satisfies the principle of correct sampling, stating that all individual parts of the lot shall have an equal probability of becoming part of the final sample. The chance that this can be achieved when the material is stationary (for example, in a silo or stockpile, or in a lorry or ship) is low. It is easier when the material is moving (for example, on a conveyor belt, or being loaded into or unloaded from transport equipment). Hence sampling from moving materials is to be preferred wherever possible.

It is important to regularly ensure that the equipment in use is properly cleaned and maintained. If the equipment shows signs of not functioning in accordance with the intended use, action shall be taken to test and repair or replace it.

The integrity of the sampled material should be ensured, e.g. avoiding loss or gain of moisture, fines, etc. This is done by temporarily storing the sample in an airtight plastic container upon collection. All sample storage shall be done according to **14.1**.

All sampling equipment shall be handled according to the described use, and it is important to ensure uniform extractions in repeated use.

The sampler should always ensure that all extracted material is transferred from the sampling device to a sample container, without loss or gain.

If an increment or combined sample mass (volume) is too large to be handled or transported, the mass shall be reduced according to the methods described in Doc. No.: PCD 07 (20276).

All personnel performing sampling shall be properly instructed or trained in the specific use of the device or method, and preferably understand the consequences of improper use of it to avoid human influence on sample quality. All rules and legislation with regard to health and safety shall be respected at all times. Precautionary measures such as the wearing of an appropriate dust mask during sample collection should be practiced.

## **11.2 Methods for Sampling Stationary Material**

### **11.2.1 Sampling from Small Packages (Less Than 50 kg)**

When sampling a lot consisting of individual packages, a primary increment consists of an entire or partial package. Packages shall be chosen at random from the entire lot, making sure all packages have an equal probability of being selected. The number of selected packages (increments) shall be calculated according to **7.5** and equation (6).

If the packages are transported on a conveyor, a lot can be defined as a certain time frame, a certain number of packages or similar. Increments shall then be chosen either systematically, randomly from defined strata, or completely at random, from the entire lot.

If the packages are stored, it is important to ensure that packages are chosen at random from the entire lot. If the packages are bundled and wrapped on pallets it may be necessary to minimize the number of opened pallets, but then the possible consequences of not respecting the principle of correct sampling shall be stated in the sampling report. Likewise, when access to all pallets is difficult, or impossible, this shall also be clearly stated in the sampling report.

### **11.2.2 Sampling from Containers, Lorries and Wagons**

An individual container, lorry or wagon load, may be regarded as the entire lot/sub-lot, or a part of the lot (*see 5.4*). If the lot consists of a single container, the increments shall be extracted from different parts of the container, chosen at random. If the lot consists of more than one container, increments shall be extracted from either all, or a fraction of, the number of containers, dependent on the required number of increments. The fraction of the number of containers sampled shall be stated in the sampling report. It is not recommended to extract all required increments from the same container.

When sampling containers special care shall be taken to encompass the possible segregation of the material in the container, for example, extract increments that cover the entire direction of segregation (a “drill-core” or selecting increments at different depths).

#### *Example:*

Fifteen big bags of wood pellets (500 kg each) from the same supplier are considered a lot, when delivered to a small heating plant. The required number of increments is 10, but for practical reasons, 12 increments is chosen. It is considered very likely that fines are found at the bottom part of the bags. The 12 increments are distributed as follows: four bags are selected at random and three increments are

extracted with a probe from top, middle and bottom in the bags, and the increments combined to form the final sample

When using a sampling pipe (*see* Fig. 8), insert the pipe into the material at an angle between 30 ° and 90 °. Insert the pipe completely before opening the sampling holes. Shaking the pipe can help to fill it. Take care when removing the increment from the pipe to collect all the fine particles. When using pipes with holes twisted around the perimeter of the pipe, it shall be used only at 90 °.

Alternatively, samples can be extracted from the freshly exposed surface during discharge, using a probe, auger or shovel. Care should be taken to overcome the possible rolling segregation on sloped surfaces, especially for materials with wide particle size distributions or differences in physical characteristics. It is recommended to take as many (possibly smaller) increments as possible spread on the entire surface.

It is always recommended, if possible, to sample when the biofuel is in transit, for example, during loading or unloading.

During the unloading of lorries, it is recommended to check for foreign objects.

Probes and pipes are recommended to be used for free flowing materials, e.g. grain like material, dry olive kernels, etc.

It shall always be stated in the sampling report when a sampling device cannot reach the bottom of the container, with the risk of under representing a certain particle size fraction, etc. If possible, use a long enough probe to sample along the cross-section of the bag.

### **11.2.3 *Sampling from Stockpiles***

#### **11.2.3.1 *General***

Stockpiles shall preferentially be sampled during build up or reclaiming as this ensures accessibility to all parts of the lot which in turn minimizes the effect of segregating materials. Only relatively small stockpiles (less than 40 tonne) may be sampled while stationary. The best practice for sampling large stationary stockpiles (greater than 40 tonne) is described in Annex B.

A scoop, shovel, fork, auger, grab, probe or pipe shall be used to extract increments.

#### **11.2.3.2 *Sampling from Stockpiles During Build Up or Reclaiming***

Increments shall be extracted either from the working face of the stockpile, or from the bucket of a front-end loader or grab or from a single, discrete load delivered to the stockpile before being pushed into the main stockpile. If a conveyor is used in stacking or reclaiming, or elsewhere in the material handling process, this is the optimal sampling point, and the methods for sampling moving material shall be used (*see* 11.3).

When sampling the working face of the pile, consider the possible (rolling) segregation on the surface. Ensure that a manual probe/auger or scoop is inserted at right angles to the surface, and that insertion of the probe/auger, is spread evenly over the entire surface of the pile. No portion of the increment should be lost during extraction of the scoop from the surface. Owing to the difficulty of insertion, a probe/auger shall be used only for fuels on which a full column of fuel can be extracted so that a representative increment is taken.

If sampling selected front-end loader buckets, grabs or individual discrete deliveries to the

pile, these shall be discharged onto a hard, clean, and dry surface and then the fuel shall be sampled by either full-depth sampling or dividing of the load. Full depth sampling from the unloaded fuel can be done using a probe, pipe, auger or similar. Load division can be done by sequentially shovelling the material into smaller piles, randomly selecting a smaller pile for repeated division, until the required increment volume/mass is achieved. All smaller piles shall consist of a minimum of 10 shovelfuls. Division is laborious, but when the number of shovelfuls used to build every sub-pile is large (greater than 30), chosen at random, and all material is divided, this method works very well and ensures against bias. If possible, a large riffle divider, rotating divider or similar is preferred [see Doc. No.: PCD 07 (20276)]

NOTE — If the time between initiating sampling and analysis results in a bias (for example, due to loss of moisture), the use of large equipment like front-end loaders and bulldozers can be used to create small piles.

### **11.2.3.3 Sampling from Stationary Stockpiles**

To decide the height at which the increments are taken, the sampler shall visually divide the heap into three horizontal layers, and take a number of increments from each layer in proportion to the volume contained in each layer. The positions around the circumference of the heap from which the increments are taken shall be equally-spaced. A bucket loader may be used to dig into the heap to reach the sampling points. Care shall be taken when extracting increments at the lowest part of the heap, to avoid impurities, segregation, etc. Fig. 14 shows a possible arrangement of the sampling points on a heap.

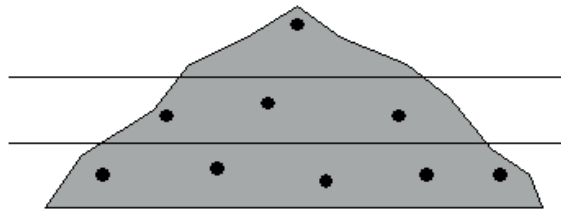

FIG. 14 SIDE VIEW OF AN EXAMPLE OF SAMPLING POINTS ON A SMALL STOCKPILE

If there is any reason to suspect that the material in the stockpile is segregated, then it is required that the material is moved (e.g. into a new stock pile) and that the increments are taken during the reclaiming or build up as described in **11.2.3.2**.

### **11.2.4 Sampling from Ships and Barges**

Sampling shall always be performed from a point where the biofuel is in transit, when possible. If it is necessary to sample from the hold of the ship, increments shall be extracted from a number of points distributed over various layers of the biofuel in the hold, which are exposed from time to time as the ship is loaded or unloaded.

A probe, auger, scoop, shovel or similar shall be used to extract increments. The aperture of the device shall comply with the description in **10.2**.

Increments shall be spaced as evenly as possible over the surface. It is important to note that segregation during handling often results in the accumulation of lumps, e.g. near one or more walls of the hold depending on the handling system. This shall be considered when selecting increment extraction points.

When extracting increments, the probe, auger, scoop or similar shall be inserted at right

angles to the surface of the fuel. No portion of the increment should be lost during extraction of the scoop from the surface. Owing to the difficulty of insertion, a probe/auger shall be used only for fuels on which a full column of fuel can be extracted so that a representative increment is taken.

If a significant amount of segregated fines is visibly noticeable as part of the shipment, a note describing this fact should be documented on the sampling certificate.

### **11.2.5 Sampling from Bales**

An individual bale may be regarded as the entire lot/sub-lot, or a part of the lot (*see 5.4*). If the lot consists of a single bale, the increments shall be extracted from different parts of the bale, chosen at random. If the lot consists of more than one bale, increments shall be extracted from either all, or a fraction of the number of bales, dependent on the required number of increments. The fraction of the number of bales sampled shall be stated in the sampling report. It is not recommended to extract all required increments from the same bale.

When sampling bales, special care shall be taken to encompass the possibility of uneven distribution of especially moisture and fines.

A minimum of two increments (for example, drill cores) shall be taken from different sides (preferably opposite sides) of the bale and to such a depth that the increments taken will represent in a correct ratio the moisture/fines distribution in the bale. If the bales seem to be uneven by quality, the number of increments shall be increased and they shall be spread representatively around the bale.

An increment consisting of a drill core traversing the entire bale across the most likely direction of moisture/fines distribution is preferred. Alternatively, a hook can be used to pull straw from as many different parts of the bale that is practically possible to form an increment, attempting to represent any uneven distribution of moisture.

NOTE — Fines are difficult to sample correctly using a hook.

## **11.3 Methods for Sampling Moving Material**

### **11.3.1 General**

The lot or sub-lot shall be defined as all the material in the container (ship hold, wagon, etc.) that the sample is to represent, or in the case of continuous production or conveying, all the material passing the sampling point during a specified time interval. An interval can also be defined in terms of mass or volume.

Increments shall be distributed over the entire lot according to one of two scenarios:

- a) Systematic increment extraction: Increments are taken at fixed time, mass or volume intervals evenly spread over the entire lot.
- b) Stratified random increment extraction: The lot is divided into equal strata (time, weight or volume) and an increment is taken from each at random. This approach is preferred when periodicities or cycles are expected in the process, to avoid taking increments at a frequency (or multiple thereof) coinciding with the frequency of the cycle.

### **11.3.2 Sampling from Falling Streams**

#### **11.3.2.1 Mechanical Sampling**

Falling-stream samplers (*see* Fig. 12) are often installed at the end of a conveyor belt or similar. When the material is falling into the cutter, it is important to avoid bouncing and filling the cutter completely. When the cutter has travelled through the stream, it shall be emptied mechanically, and no material should be lost during this operation. Often the bottom of the cutter opens, and the material simply falls into a temporary holding compartment. When the compartment is full, the material can be divided mechanically, using for instance a rotating plate divider, rotating disc divider, rotating nozzle divider or similar. Care should be taken to avoid damaging the material during the division process. While the cutter is in the park position, no material (for example, dust) should fall inside it, creating a biased next increment. It is important to inspect the cutter regularly during operation, to avoid problems with clogging, etc. Preferentially it shall be possible to change the frequency of sampling with the cutter, to allow different materials, qualities, etc. to be sampled at the same plant. To avoid biased results care shall be taken about the complete emptying of the sampling device between different biofuels and also between increments of the same biofuel.

### **11.3.2.2 Manual Sampling**

Usually, manual sampling is only suited for low mass flows.

Sampling shall be carried out using a sampling box (*see* Fig. 2) or other suitable equipment that is passed through the stream of falling material so that it cuts the whole cross section of the falling stream.

Sampling from falling streams can also be done by taking the increments from a variety of points representing the whole cross section of the falling stream of material. In these cases, careful attention shall be put on possible segregation of fuel flow. If it is not possible to take the increment covering the entire stream, it is recommended to take an increased number of increments.

### **11.3.3 Sampling from Conveyor Belts**

#### **11.3.3.1 Mechanical Sampling**

Cross-belt samplers (*see* Fig. 13) are often installed on a conveyor belt. When the material is flowing into the cutter, it is important to avoid bouncing and filling the cutter completely. When the cutter has travelled through the stream, it shall be emptied mechanically, and no material should be lost during this operation. The material from the cutter often falls into a temporary holding compartment. When the compartment is full, the material can be divided mechanically, using for instance a rotating plate divider, rotating disc divider, rotating nozzle divider or similar. Care should be taken to avoid damaging the material during the division process. While the cutter is in the park position, no material (e.g. dust) shall gather inside it, creating a biased next increment. It is important to inspect the cutter regularly during operation, to avoid problems with clogging, etc. Preferentially, it shall be possible to change the frequency of sampling with the cutter, to allow different materials, qualities, etc. to be sampled at the same plant. To avoid biased results, care shall be taken about the complete emptying of the sampling device between different biofuels and also between increments of the same biofuel.

#### **11.3.3.2 Manual Sampling**

A sampling frame (*see* Fig. 9) shall be used to separate the material to be taken as an increment. The frame shall be placed on top of the material on the stopped conveyor belt and forced to the bottom. All the material contained within the sampling frame shall be taken as the increment. If material is trapped under the edges of the frame, the material trapped under one

edge shall be included in the increment and the material trapped under the other edge shall be excluded from the increment.

#### **11.3.4 Sampling from Bucket Conveyors, Drag Conveyors, Bucket Loaders or Grabs**

A number of bucketfuls, grabfuls or compartments of the drag conveyor shall be selected for sampling during the discharge of the lot or sub-lot.

Either take all of a selected bucketful, grabful or a compartment of the drag conveyor as an increment, or take a smaller representative increment by

- a) emptying the entire contents onto a clean, hard surface, and take an increment from the tipped material according to the method described in **11.2.3.2** (stockpiles, during build up/reclaiming),
- b) taking an increment in the bucket, drag conveyor, etc. by digging into the material as many times as feasible, and at different depths, to form a combined increment. This is the case if the material cannot be emptied from the bucket, etc.

### **11.4 Sampling of Roundwood**

#### **11.4.1 General Method**

Select the appropriate number of logs according to the required number of increments (**7.5**). Cut one slice (disc), with an individual thickness of approximately 3 cm to 5 cm from the centre of each log. Each slice shall be considered as an increment. If the moisture content shall be measured, cut at least three slices (discs), spread evenly along the length of each log, avoiding the end parts (0.20 m; *see* NOTE). Alternatively, for moisture content samples, the method described in **11.4.2** can be applied. A best effort should be made to ensure that the entire lot is represented when selecting where to cut for the extraction of slices/discs.

NOTE — Moisture can systematically change along the length of round wood logs due to drying from the end surface.

It is recommended to use a power saw to avoid or minimize loss of moisture and contamination with lubricants, etc. If using a chainsaw, it should preferably be operated without the use of chain oil. Thus, extreme care should be taken to avoid heating of the chain and the possible personal hazard from such.

If necessary, the slices (discs) are subsequently carefully divided into smaller pieces with a hand axe/chisel and hammer. If mass reduction is necessary, the reduced part of the disc should represent heartwood, sapwood and eventually, the bark in the same proportions as the whole disc.

Further sample preparation (cutting, crushing and dividing) at the laboratory shall be in accordance with Doc. No.: PCD 07 (20276). Care should be taken to avoid loss of moisture at all stages.

#### **11.4.2 Method for Fast Moisture-Content Determination**

Sampling of roundwood is to be done immediately before or after the determination of the weight (as received) of the delivery.

The number of cuts (increments) shall be calculated according to equation 6.



The log sampling shall be done with the help of powered wood-forming tools, e.g. chainsaw, circular saw, chain mortiser (preferably with sawdust collector), taking into account that the tools are sharpened and properly adjusted.

Sampling with a chainsaw is done by cutting the logs halfway and stopping when the core of the log is reached or cutting through the whole log creating two pieces and collecting the sawdust. If the average diameter of the logs in the lot is bigger than 30 cm, sampling can be undertaken by cutting circular sections with a chain saw.

Cutting with other powered wood-forming tools is done by piercing the log to be sampled until reaching the core of the log.

For long logs (greater than equal to 2 m), the cutting shall be done with a distance of at least 50 cm from the ends of the log and in the case of short logs (less than 2 m), at least 15 cm from the ends.

If the collector is filled with sawdust (particularly with logs of large dimensions), the collector shall be emptied or replaced by a second collector. All the collected sawdust from one delivery lot shall be mixed and homogenized before taking the analysis sample.

The whole quantity of sawdust produced by sampling one delivery lot shall be preserved in air-tight plastic containers or bags protected against outside influences. The samples shall be labelled and the sampling information shall be documented.

For safety reasons, all necessary safety precautions for the work with chainsaws, like security clothing and chainsaws with safety features shall be implemented.

Large snow loads, ice or dirt shall be removed before sampling.

NOTE — Moisture content is not uniform in the log. For example, heartwood usually contains less moisture than sapwood. In the case of fresh coniferous wood, the moisture content of the heartwood is about 35 percent and of sapwood around 55 percent. In the case of broad-leaf wood, the difference is significantly smaller. It is also possible that the heartwood has a higher moisture content than the sapwood, for example in the case of the poplar.

## **12 SAMPLE GENERATION FOR COMBINED SAMPLES AND LABORATORY SAMPLES**

**12.1** One of the following options shall be used:

- a) All the increments are placed directly into one container to form a combined sample, which is sent to the laboratory. In this case the combined sample is also the laboratory sample.
- b) The increments are mixed together to form a combined sample, which is then divided and prepared as described in Doc. No.: PCD 07 (20276).
- c) Each increment is placed in a separate container, and sent to the laboratory. The laboratory combines the increments to form the laboratory sample.

It is recommended that the samples are mixed prior to division preferably on a dry- and dust-free sampling site.

## **13 PERFORMANCE CHARACTERISTICS**

The overall precision of sampling of the lot (characterizes the precision for the lot, either as a

specification which shall be reached or for the result which has been obtained) can be calculated using the calculation as described in 7, for each sampling scheme individually. The formula below is used:

$$P_L = 2 \times \sqrt{\frac{V_i}{n \times N_{SL}} + \frac{V_{PT}}{N_{SL}}} \text{ ----- (11)}$$

Reference values for specific materials for  $V_i$  and  $V_{PT}$  can be found in Annex D.

## **14 HANDLING AND STORAGE OF SAMPLES**

### **14.1 Packaging, Storing and Transport of Samples**

Depending on the parameter to be determined, extra care should be taken.

- a) Sample shall be placed in air-tight packages such as plastic buckets (with lids) or plastic bags (to be closed).
- b) Sample can be placed in a box or other convenient packaging when only particle size distribution is to be determined.
- c) Sample shall be kept away from direct sunlight if transparent packaging is used.
- d) Sample container shall be sealed when it is necessary to guard against aging of the sample.
- e) Sample shall be submitted for testing within 24 h when it is necessary to minimize biological activity, or the sample can be stored in a refrigerator or cold room at 4 °C or below and analyzed as soon as possible, in most cases after no longer than one week. Check the sample at periodic intervals for the presence of fungi (mould) and other symptoms of increased biological activities. In this case, the sample should be treated immediately. Alternatively, the sample shall be air-dried as described in Doc. No.: PCD 07 (20276) or deep-frozen (less than equal to 18 °C). If the moisture content is to be determined, the weight loss caused by air-drying shall be recorded and submitted together with the air-dry sample.
- f) Sample may be stored in a dry cool area for no longer than six months if little or no biological activity occurs.
- g) Integrity of the sample should always be safeguarded during storage.

### **14.2 Identification/Labelling**

The container shall carry a label showing:

- a) the unique identification number of the sample;
- b) the date and time of sampling; and
- c) the identification number or code of the lot or sub-lot number. And when necessary;
- d) the type of biofuel and form (chips, pellets, briquettes, logs, etc.);
- e) the reference number of the sampling plan; and
- f) the name of the sampler.

## 15 SAMPLING CERTIFICATES

A sampling certificate shall either contain all the information required by the full sampling plan or contain all the information required by the brief sampling plan.

When a unique delivery ticket is used, also as a sampling plan, a brief sampling plan should be either included or added to it by the supplier.

**ANNEX A**  
(Clauses 5.1, 5.2 and 5.3)  
**MODEL SAMPLING PLAN AND SAMPLING CERTIFICATE**

**Table 1 Example of Sampling Plan**  
(Clause 9)

|   |          |               |   |           |
|---|----------|---------------|---|-----------|
| Sampling plan reference number  |          |               |   |           |
| Unique sample identification number   |          |               | Date  |           |
| Aim of sampling   |          |               |   |           |
| Property  | Standard | Mass required | Sampling equipment  |           |
| Moisture  |          | kg            | Manual  | Automatic |
| Particle size distribution  |          | kg            | Scoop <input type="checkbox"/><br>Shovel <input type="checkbox"/><br>Fork <input type="checkbox"/><br>Grab <input type="checkbox"/><br>Other: |           |
| Bulk density  |          | kg            |   |           |
| Mechanical  |          | kg            |   |           |
| Ash   |          | kg            |   |           |
| Calorific value   |          | kg            |   |           |
| Sulfur  |          | kg            |   |           |
| Nitrogen  |          | kg            | Location of sampling point:   |           |
| Chlorine  |          | kg            |   |           |
| Others:   |          |               |   |           |
|   |          | kg            | Procedure for selecting sub-lots from lots for sampling   |           |
|   |          | kg            |   |           |
|   |          | kg            |   |           |
|   |          |               | Requirements according to standard:   |           |
| Total mass required for tests   |          | kg            | Min. number of increments ( $n_{min}$ )   |           |
| Bulk density  |          | $kg/m^3$      | Min. volume, one increment ( $V_{incr}$ )   |           |
| Total volume required for tests ( $V_{req}$ )   |          | litre         | Volume of combined sample ( $V_{Combined\ Sample}$ )  |           |
| If total volume required ( $V_{req}$ ) exceeds the calculated volume of combined sample ( $V_{Combined\ Sample}$ ), then increase the number or the volume of increments: |          |               | Method of preparing the laboratory sample from the combined sample:   |           |

|  |       |                                 |       |
|--|-------|---------------------------------|-------|
| Actual number of increments ( $n_{act}$ ), larger than $V_{req}/V_{incr}$      |       |                                 |       |
| Actual volume of increments ( $V_{incr, act}$ ), larger than $V_{req}/n_{act}$ |       |                                 |       |
| Actual volume of the combined sample ( $n_{act} \times V_{incr, act}$ )        | litre | Volume of the laboratory sample | litre |

**ANNEX B**  
(Clause 11.2.3.1)  
**SAMPLING FROM LARGE STOCKPILES**

**B-1 INITIAL ASSESSMENT OF THE STOCKPILE**

The sampler shall inspect the stockpile visually. If the stockpile appears to contain significantly deviating areas, sub-lots of each area shall be made. The sampler shall sample each sub-lot and make a note of the estimated proportions of each area on the sampling certificate.

The sampler shall establish how the stockpile was formed as this can cause the stockpile to be heterogeneous. For example, if material is allowed to fall from the end of a conveyor to form a stockpile in the form of a conical heap, coarser particles tend to collect at the outside and at the base of the stockpile, and finer particles collect in the interior of the stockpile. However, if such a stockpile is exposed to the wind, then finer particles will be carried by the wind to the downwind side of the stockpile. If a stockpile is built over a lengthy time period, the inaccessible material on the inside may be totally different from the accessible material on the outside or at the different end of a long stockpile.

**B-2 TAKING SAMPLES**

Take the increments manually using a scoop, shovel or fork or pipe. If segregation is expected to occur during sampling, drive a board or metal plate horizontally into the heap and withdraw the increment immediately underneath. The increments shall be taken mass proportionally if possible.

Holes or ditches should be dug using, for example, a front end bucket loader. If possible, these holes or ditches should be dug from the top of the stockpile and down to 4/5 of the height of the stockpile. If this is not possible, the holes or ditches should be dug from the sides of the stockpile (evenly distributed). From the excavated material, increments can be taken using a scoop, shovel or fork.

As alternative, mechanical probes and augers can be used for sampling in the same way as for railway wagons and ships; *see* **11.2.2** and **11.2.4**.

**B-3 MARKING, PACKAGING AND DISPATCH OF SAMPLES**

For marking, packaging and dispatch of samples refer **14**.

**B-4 CERTIFICATE OF SAMPLING**

The sampler shall prepare a sampling certificate according to **15**. He shall report that the

sampling was undertaken on a large stationary stockpile and any other reasons why the sample may not be representative of the stockpile on the sampling certificate.

**ANNEX C**  
*(Clause 9)*  
**BULK DENSITIES OF SOLID BIOFUELS**

**C-1** Typical bulk densities for solid biofuels are given in Table 2. These values can be used in case no other information on bulk density is available.

**Table 2 Typical Bulk Densities of Biofuels**  
*(Clause C-1)*

| SI No. | Biofuel                         | Bulk density, kg/m <sup>3</sup> |
|--------|---------------------------------|---------------------------------|
| (1)    | (2)                             | (3)                             |
| i.     | Pellets                         | 550 to 700                      |
| ii.    | Briquettes                      | 500 to 650                      |
| iii.   | Fuel powder                     | 150 to 250                      |
| iv.    | Dry fuel powder                 | 100 to 150                      |
| v.     | Bark                            | 250 to 400                      |
| vi.    | Sawdust                         | 250 to 380                      |
| vii.   | Shavings                        | 80 to 170                       |
| viii.  | Wood chips                      | 250 to 400                      |
| ix.    | Straw bales                     | 130 to 180                      |
| x.     | Chopped straw                   | 80 to 120                       |
| xi.    | Reed canary grass, round bales  | ~165                            |
| xii.   | Reed canary grass, square bales | ~125                            |
| xiii.  | Reed canary grass, chopped      | 30 to 80                        |
| xiv.   | Miscanthus chopped              | 100 to 120                      |

**ANNEX D**  
*(Foreword, Clauses 7.2, 7.3, 7.5, 13, E-1, E-2, E-3.1.1, E- 3.1.2, E-3.2 and E-3.3)*  
**REFERENCE VALUES FOR  $V_i$  AND  $V_{PT}$**

**D-1 GENERAL**

The determination of  $V_i$ ,  $V_{PT}$  and  $n_{min}$  are described in 7. If values cannot be determined in this procedure, the values given in this annex should be assumed initially. The assumptions should preferably be verified afterwards if possible. The required overall precision,  $P_L$ , on a lot should be agreed between the parties concerned. In the absence of such agreement, the values given in Table 3 to Table 13 may be assumed. The number of increments per sub-lot can be calculated depending on the number of sub-lots, the values of  $V_i$  and  $V_{PT}$  and the chosen value of  $P_L$ . See Table 14 to Table 22 for the numbers of increments per sub-lot calculated using the reference values in the Table 3 to Table 13.

**D-2 REFERENCE VALUES FOR DIFFERENT TYPES OF SOLID BIOFUELS**

If the variances, the primary increment variance  $V_i$  and the preparation and testing variance  $V_{PT}$  are not known, the reference values for  $V_i$  and  $V_{PT}$  in the tables below may be used. Suggested values for the overall precision  $P_L$  which may be used in case of lack of agreement between the parties concerned are also presented in the tables.

The actual number of increments to be taken per sub-lot based on the below stated reference values of

$V_i$  and  $V_{PT}$  can be found in Annex E.

**Table 3 Mixed Wood Pellets (6 mm to 8 mm) from Different Sources**  
(Clauses 7.4; 7.5; D-1 and Table 15)

| SI No. | Parameter                                 | Suggested Precision<br>( $P_L$ ) | Increment Variance<br>( $V_i$ ) | Preparation and Test Variance<br>( $V_{PT}$ ) |
|--------|---|----------------------------------|---------------------------------|---|
| (1)    | (2)                                       | (3)                              | (4)                             | (5)   |
| i.     | Total moisture, weight percent            | 0.20                             | 0.34                            | 0.002   |
| ii.    | Ash (db), weight                          | 0.20                             | 0.53                            | 0.015   |
| iii.   | Gross Calorific value (db), MJ/kg         | 0.100                            | 0.038                           | 0.006 1                                       |
| iv.    | Fines, less than equal to 3.15 mm, weight | 1.0                              | 8.8                             | 0.39  |

**Table 4 Wood Pellets (6 mm) produced from One Production Site with a Constant Quality of Raw Materials**  
(Clauses 7.4; 7.5; D-1 and Table 15)

| SI No. | Parameter                             | Suggested Precision<br>( $P_L$ ) | Increment Variance<br>( $V_i$ ) | Preparation and Test Variance<br>( $V_{PT}$ ) |
|--------|---------------------------------------|----------------------------------|---------------------------------|---|
| (1)    | (2)                                   | (3)                              | (4)                             | (5)   |
| i.     | Total moisture, weight percent        | 0.20                             | 0.025                           | 0.014   |
| ii.    | Ash (db), weight percent              | 0.20                             | 0.000 8                         | 0.007 1                                       |
| iii.   | Mechanical durability, weight percent | 0.20                             | 0.005                           | 0.001 6                                       |

**Table 5 Wood Pellets (8 mm) from Stemwood from One Production Site**  
(Clauses 7.4; 7.5; D-1 and Table 15)

| SI No. | Parameter | Suggested precision<br>( $P_L$ ) | Increment variance<br>( $V_i$ ) | Preparation and test variance<br>( $V_{PT}$ ) |
|--------|-----------|----------------------------------|---------------------------------|---|
| (1)    | (2)       | (3)                              | (4)                             | (5)   |

|      |  |      |         |         |
|------|--|------|---------|---------|
| i.   | Total moisture, weight percent             | 0.20 | 1.35    | 0.002   |
| ii.  | Ash (db), weight percent                   | 0.20 | 0.000 4 | 0.000 3 |
| iii. | Particle size distribution, weight percent | 0.1  | 0.045   | 0.001   |

**Table 6 Mixed Wood Pellets (8 mm) from One Production Site with Changing Raw Material Quality**  
(Clauses 7.4; 7.5; D-1; E-3.2 and Table 15)

| SI No. | Parameter                             | Suggested precision | Increment variance | Preparation and test variance |
|--------|---------------------------------------|---------------------|--------------------|-------------------------------|
|        |                                       | $(P_L)$             | $(V_i)$            | $(V_{PT})$                    |
| (1)    | (2)                                   | (3)                 | (4)                | (5)                           |
| i.     | Total moisture, weight percent        | 0.20                | 0.958              | 0.003                         |
| ii.    | Ash (db) , weight percent             | 0.20                | 0.005 4            | 0.000 3                       |
| iii.   | Mechanical durability, weight percent | 0.20                | 0.208              | 0.006 1                       |

**Table 7 Woodchips, Including Bark with a Nominal Top Size of 16 mm**  
(Clauses 7.4; 7.5 and D-1)

| SI No. | Parameter                                  | Suggested precision | Increment variance | Preparation and test variance |
|--------|--|---------------------|--------------------|-------------------------------|
|        |  | $(P_L)$             | $(V_i)$            | $(V_{PT})$                    |
| (1)    | (2)  | (3)                 | (4)                | (5)                           |
| i.     | Total moisture, weight percent             | 1.00                | 12.5               | 0.059                         |
| ii.    | Ash (db) , weight percent                  | 0.10                | 0.05               | 0.000 4                       |
| iii.   | Particle size distribution, weight percent | 2                   | 25.4               | 0.86                          |

**Table 8 Sawdust from Conifer**  
(Clauses 7.4; 7.5; D-1 and Table 17)

| SI No. | Parameter                      | Suggested precision | Increment variance | Preparation and test variance |
|--------|--------------------------------|---------------------|--------------------|-------------------------------|
|        |                                | $(P_L)$             | $(V_i)$            | $(V_{PT})$                    |
| (1)    | (2)                            | (3)                 | (4)                | (5)                           |
| i.     | Total moisture, weight percent | 1.00                | 6.0                | 0.06                          |
| ii.    | Ash (db), weight percent       | 0.10                | 0.003              | 0.000 6                       |

|      |  |   |    |     |
|------|--|---|----|-----|
| iii. | Particle size distribution, weight percent | 2 | 14 | 1.6 |
|------|--|---|----|-----|

**Table 9 Bark from Scots Pine with a Nominal Top Size of 100 mm**  
(Clauses 7.4; 7.5; D-1 and Table 18)

| SI No. | Parameter                         | Suggested precision<br>( $P_L$ ) | Increment variance<br>( $V_i$ ) | Preparation and test variance<br>( $V_{PT}$ ) |
|--------|-----------------------------------|----------------------------------|---------------------------------|---|
| (1)    | (2)                               | (3)                              | (4)                             | (5)   |
| i.     | Total moisture, weight percent    | 1.00                             | 8.00                            | 0.68  |
| ii.    | Ash (db), weight percent          | 0.15                             | 0.019                           | 0.015   |
| iii.   | Gross calorific value (db), MJ/kg | 0.100                            | 0.081                           | 0.0042  |

**Table 10 Logging Residue from Conifer with Nominal Top Size of 64 mm**  
(Clauses 7.4; 7.5; D-1 and Table 19)

| SI No. | Parameter                                  | Suggested precision<br>( $P_L$ ) | Increment variance<br>( $V_i$ ) | Preparation and test variance<br>( $V_{PT}$ ) |
|--------|--|----------------------------------|---------------------------------|---|
| (1)    | (2)  | (3)                              | (4)                             | (5)   |
| i.     | Total moisture, weight percent             | 1.5                              | 10                              | 0.73  |
| ii.    | Ash (db), weight percent                   | 1                                | 1.15                            | 0.37  |
| iii.   | Particle size distribution, weight percent | 5                                | 54                              | 25.6  |

**Table 11 Straw from Wheat in Bales**  
(Clauses 7.4; 7.5; D-1 and Table 20)

| SI No. | Parameter                      | Suggested precision<br>( $P_L$ ) | Increment variance<br>( $V_i$ ) | Preparation and test variance<br>( $V_{PT}$ ) |
|--------|--------------------------------|----------------------------------|---------------------------------|---|
| (1)    | (2)                            | (3)                              | (4)                             | (5)   |
| i.     | Total moisture, weight percent | 2.5                              | 100                             | 3.06  |
| ii.    | Ash (db), weight percent       | 0.5                              | 1.17                            | 0.06  |
| iii.   | Chlorine, weight percent       | 0.02                             | 0.01                            | 0.000 05                                      |

**Table 12 Olive Residue, Typical Mediterranean Materials with a Nominal Top Size of 3 mm**  
(Clauses 7.4; 7.5; D-1 and Table 21)

| SI No. | Parameter | Suggested precision<br>( $P_L$ ) | Increment variance<br>( $V_i$ ) | Preparation and test variance<br>( $V_{PT}$ ) |
|--------|-----------|----------------------------------|---------------------------------|---|
|--------|-----------|----------------------------------|---------------------------------|---|



| (1)   | (2)                          | (3)   | (4)       | (5)       |
|-------|------------------------------|-------|-----------|-----------|
| i.    | Moisture, weight percent     | 0.04  | 0.23      | 0.029     |
| ii.   | Ash (db), weight percent     | 1     | 1.5       | 0.53      |
| iii.  | Aluminum (Al)                | 150   | 23 000    | 15 000    |
| iv.   | Calcium (Ca)                 | 1 500 | 1 100 000 | 1 300 000 |
| v.    | Magnesium (Mg)               | 500   | 30 000    | 160 000   |
| vi.   | Sodium (Na)                  | 50    | 4 000     | 1 700     |
| vii.  | Phosphorus (P)               | 50    | 4 010     | 1 300     |
| viii. | Silicon (Si)                 | 2 000 | 3 600 000 | 1 700 000 |
| ix.   | Potassium (K)                | 1 000 | 620 000   | 270 000   |
| x.    | Nitrogen (N), weight percent | 0.1   | 0.01      | 0.007     |

**Table 13 Grape Residue, Typical Mediterranean Materials with a Nominal Top Size of 16 mm**  
(Clause D-1 and Table 22)

| SI No. | Parameter                    | Suggested precision<br>( $P_L$ ) | Increment variance<br>( $V_i$ ) | Preparation and test variance<br>( $V_{PT}$ ) |
|--------|------------------------------|----------------------------------|---------------------------------|---|
| (1)    | (2)                          | (3)                              | (4)                             | (5)   |
| i.     | Moisture, weight percent     | 1.5                              | 6.8                             | 1.9   |
| ii.    | Ash (db), weight percent     | 1                                | 0.72                            | 0.20  |
| iii.   | Aluminum (Al)                | 150                              | 12 000                          | 5 500   |
| iv.    | Calcium (Ca)                 | 3 500                            | 11 000 000                      | 5 100 000                                     |
| v.     | Magnesium (Mg)               | 200                              | 22 000                          | 10 000  |
| vi.    | Sodium (Na)                  | 50                               | 12 000                          | 550   |
| vii.   | Phosphorus (P)               | 200                              | 72 000                          | 20 000  |
| viii.  | Silicon (Si)                 | 1 000                            | 160 000                         | 370 000                                       |
| ix.    | Potassium (K)                | 1 500                            | 3 400 000                       | 1 200 000                                     |
| x.     | Nitrogen (N), weight percent | 0.1                              | 0.009                           | 0.004 5                                       |

**ANNEX E**  
(Clause D-2)  
(Informative)

**GUIDELINES FOR THE NUMBER OF INCREMENTS TO BE TAKEN**

**E-1 GENERAL**

Clause 8 describes how the number of increments should be calculated, on the basis of measured values of the primary increment variance  $V_i$  and the preparation and testing variance  $V_{PT}$  and an agreed value of the overall precision for the sampling,  $P_L$ . If  $V_i$  and  $V_{PT}$  are not known and/or there is no agreed value of  $P_L$ , the suggested values stated in Annex D may be used.

**E-2 ESTIMATION OF THE NUMBER OF INCREMENTS FROM REFERENCE VALUES**

In the tables below, the number of increments to be taken per sub-lot (depending on the number of sub-lots) based on the reference values in Annex D, are stated. Values of “10” indicate

that the calculated minimum number of increments is 10 or less (*see 7.5*).

NOTE — These tables sometimes show that for a small number of sub-lots a large amount of increments are needed which is impracticable. In some cells, “too low  $P_L$ ” is given, indicating that any amount of increments would not yield the required precision; more sub-lots would then be needed. Or alternatively, the overall precision ( $P_L$ ) can be changed if agreed upon by the involved parties.

**Table 14 Number of Increments Per (Sub-) Lot for Wood Pellets (6 mm to 8 mm)  
from Different Sources  
(Clause D-1)**

| SI No. | Number of<br>sub-lots<br>( $N_{SL}$ ) | Number of increments ( $n$ ) per (sub-) lot            |                                       |   |   |
|--------|---------------------------------------|--|---------------------------------------|---|---|
|        |                                       | Total<br>moisture,<br>weight<br>percent<br>$P_L = 0.2$ | Ash, weight<br>percent<br>$P_L = 0.2$ | GCV (db <sup>a</sup> ),<br>MJ/kg<br>$P_L = 0.1$ | Fines less than equal to<br>3.15 mm, weight<br>percent<br>$P_L = 1.0$ |
| (1)    | (2)                                   | (3)  | (4)                                   | (5)   | (6)   |
| i.     | 1                                     | 43   | too low $P_L$                         | too low $P_L$                                   | too low $P_L$   |
| ii.    | 2                                     | 19   | 106                                   | too low $P_L$                                   | 80  |
| iii.   | 3                                     | 12   | 35                                    | 27  | 24  |
| iv.    | 4                                     | 10   | 21                                    | 10  | 14  |
| v.     | 5                                     | 10   | 15                                    | 10  | 10  |
| vi.    | 6                                     | 10   | 12                                    | 10  | 10  |
| vii.   | 7                                     | 10   | 10                                    | 10  | 10  |
| viii.  | 8                                     | 10   | 10                                    | 10  | 10  |
| ix.    | 9                                     | 10   | 10                                    | 10  | 10  |
| x.     | 10                                    | 10   | 10                                    | 10  | 10  |

<sup>a</sup>) Gross Caloric Value (db): dry basis.

**Table 15 Number of Increments Per (Sub-) Lot for Wood Pellets (6 mm to 8 mm) produced  
from One Production Site  
(Clause D-1)**

| SI No. | Number of<br>sub-lots<br>( $N_{SL}$ ) | Number of increments ( $n$ ) per (sub-) lot      |                                       |   |  |
|--------|---------------------------------------|--|---------------------------------------|---|--|
|        |                                       | Total moisture,<br>weight percent<br>$P_L = 0.2$ | Ash, weight<br>percent<br>$P_L = 0.2$ | Mechanical<br>durability<br>$P_L = 0.1$ | Particle Size<br>Distribution,<br>weight<br>percent<br>$P_L = 1.0$ |
| (1)    | (2)                                   | (3)  | (4)                                   | (5)                                     | (6)  |
| i.     | 1                                     | too low $P_L$                                    | 10                                    | 53                                      | 30   |
| ii.    | 2                                     | 10   | 10                                    | 15                                      | 11   |
| iii.   | 3                                     | 10   | 10                                    | 10                                      | 10   |
| iv.    | 4                                     | 10   | 10                                    | 10                                      | 10   |
| v.     | 5                                     | 10   | 10                                    | 10                                      | 10   |

NOTES

1 From one production unit with constant incoming raw materials and consisting of up to three months production.

2 Data used in this table originates from Tables 3, 4, 5 and 6.

**Table 16 Number of Increments Per (Sub-) Lot for Woodchips, Including Bark with a Nominal Top Size of 16 mm**  
(Clause D-1)

| SI No. | Number of sub-lots<br>( $N_{SL}$ ) | Number of increments ( $n$ ) per sub-(lot)    |                                    |   |
|--------|------------------------------------|---|------------------------------------|---|
|        |                                    | Total moisture, weight percent<br>$P_L = 1.0$ | Ash, weight percent<br>$P_L = 0.1$ | Particle size distribution, weight percent<br>$P_L = 2.0$ |
| (1)    | (2)                                | (3)   | (4)                                | (5)   |
| i.     | 1                                  | 65  | 24                                 | 181   |
| ii.    | 2                                  | 28  | 11                                 | 22  |
| iii.   | 3                                  | 18  | 10                                 | 12  |
| iv.    | 4                                  | 13  | 10                                 | 10  |
| v.     | 5                                  | 10  | 10                                 | 10  |

NOTES

1 Sieve range used for particle size distribution: 16 mm, 8 mm, 5 mm, 3 mm and 2 mm.

2 Data used in this table originates from Table 7.

**Table 17 Number of Increments Per (Sub-) Lot for Sawdust from Conifer**  
(Clause D-1)

| SI No. | Number of sub-lots<br>( $N_{SL}$ ) | Number of increments ( $n$ ) per sub-(lot)    |                                    |   |
|--------|------------------------------------|---|------------------------------------|---|
|        |                                    | Total moisture, weight percent<br>$P_L = 1.0$ | Ash, weight percent<br>$P_L = 0.1$ | Particle size distribution, weight percent<br>$P_L = 2.0$ |
| (1)    | (2)                                | (3)   | (4)                                | (5)   |
| i.     | 1                                  | 32  | 10                                 | too low $P_L$   |
| ii.    | 2                                  | 14  | 10                                 | 35  |
| iii.   | 3                                  | 10  | 10                                 | 10  |
| iv.    | 4                                  | 10  | 10                                 | 10  |
| v.     | 5                                  | 10  | 10                                 | 10  |

NOTES

1 Sieve range used for particle size distribution: 5.6 mm, 4.0 mm, 2.8 mm, 2.0 mm, 1.4 mm, 1.0 mm and 0.5 mm.

2 Data used in this table originates from Table 8.

**Table 18 Number of Increments Per (Sub-) Lot for Bark, Bark from Scots Pine with a Nominal Top Size of 100 mm**

(Clause D-1)

| SI No. | Number of sub-lots<br>( $N_{SL}$ ) | Number of increments ( $n$ ) per sub-(lot)    |                                     |                               |
|--------|------------------------------------|---|-------------------------------------|-------------------------------|
|        |                                    | Total moisture, weight percent<br>$P_L = 1.0$ | Ash, weight percent<br>$P_L = 0.15$ | GCV(db), MJ/kg<br>$P_L = 0.1$ |
| (1)    | (2)                                | (3)   | (4)                                 | (5)                           |
| i.     | 1                                  | too low $P_L$                                 | too low $P_L$                       | too low $P_L$                 |
| ii.    | 2                                  | too low $P_L$                                 | too low $P_L$                       | 101                           |
| iii.   | 3                                  | 114   | 10                                  | 25                            |
| iv.    | 4                                  | 25  | 10                                  | 14                            |
| v.     | 5                                  | 14  | 10                                  | 10                            |
| vi.    | 6                                  | 10  | 10                                  | 10                            |

NOTE — Data used in this table originates from Table 9.

**Table 19 Number of Increments Per (Sub-) Lot for Logging Residue, from Conifer with Nominal Top Size of 64 mm**  
(Clause D-1)

| SI No. | Number of sub-lots<br>( $N_{SL}$ ) | Number of increments ( $n$ ) per sub-(lot)    |                                    |   |
|--------|------------------------------------|---|------------------------------------|---|
|        |                                    | Total moisture, weight percent<br>$P_L = 1.5$ | Ash, weight percent<br>$P_L = 1.0$ | Particle size distribution, weight percent<br>$P_L = 5.0$ |
| (1)    | (2)                                | (3)   | (4)                                | (5)   |
| i.     | 1                                  | too low $P_L$                                 | too low $P_L$                      | too low $P_L$   |
| ii.    | 2                                  | 25  | 10                                 | too low $P_L$   |
| iii.   | 3                                  | 10  | 10                                 | too low $P_L$   |
| iv.    | 4                                  | 10  | 10                                 | too low $P_L$   |
| v.     | 5                                  | 10  | 10                                 | 10  |

NOTE — Data used in this table originates from Table 10.

**Table 20 Number of Increments Per Sub-Lot from Wheat Straw in Bales**  
(Clause D-1)

| SI No. | Number of sub-lots<br>( $N_{SL}$ ) | Number of increments ( $n$ ) per sub-(lot)    |                                    |  |
|--------|------------------------------------|---|------------------------------------|--|
|        |                                    | Total moisture, weight percent<br>$P_L = 2.5$ | Ash, weight percent<br>$P_L = 0.5$ | Chlorine, weight percent<br>$P_L = 0.02$ |
| (1)    | (2)                                | (3)   | (4)                                | (5)                                      |
| i.     | 1                                  | too low $P_L$                                 | 468                                | 200                                      |
| ii.    | 2                                  | 1 538   | 18                                 | 67                                       |
| iii.   | 3                                  | 61  | 10                                 | 40                                       |
| iv.    | 4                                  | 31  | 10                                 | 29                                       |

|       |    |    |    |    |
|-------|----|----|----|----|
| v.    | 5  | 21 | 10 | 22 |
| vi.   | 6  | 16 | 10 | 18 |
| vii.  | 7  | 13 | 10 | 15 |
| viii. | 8  | 11 | 10 | 13 |
| ix.   | 9  | 10 | 10 | 12 |
| x.    | 10 | 10 | 10 | 11 |

NOTE — Data used in this table originates from Table 11.

**Table 21 Number of Increments Per (Sub-) Lot for Olive Residue, Typical Mediterranean Materials with a Nominal Top Size of 3 mm**  
(Clause D-1)

| SI No. | Number of sub-lots        | Number of increments ( <i>n</i> ) per sub-(lot) <sup>a)</sup> |                                 |                                 |                                 |                                 |                                 |                                 |                                 |                                 |                                 |
|--------|---------------------------|---|---------------------------------|---------------------------------|---------------------------------|---------------------------------|---------------------------------|---------------------------------|---------------------------------|---------------------------------|---------------------------------|
|        |                           | Moisture  | Ash                             | Al                              | Ca                              | Mg                              | Na                              | P                               | Si                              | K                               | N                               |
|        | ( <i>N<sub>SL</sub></i> ) | <i>P<sub>L</sub></i> = 0.4                                    | <i>P<sub>L</sub></i> = 1.0      | <i>P<sub>L</sub></i> = 150      | <i>P<sub>L</sub></i> = 1 500    | <i>P<sub>L</sub></i> = 500      | <i>P<sub>L</sub></i> = 50       | <i>P<sub>L</sub></i> = 50       | <i>P<sub>L</sub></i> = 2 000    | <i>P<sub>L</sub></i> = 1 000    | <i>P<sub>L</sub></i> = 0.10     |
| (1)    | (2)                       | (3)   | (4)                             | (5)                             | (6)                             | (7)                             | (8)                             | (9)                             | (10)                            | (11)                            | (12)                            |
| i.     | 1                         | 21  | too low<br><i>P<sub>L</sub></i> | too low<br><i>P<sub>L</sub></i> | too low<br><i>P<sub>L</sub></i> | too low<br><i>P<sub>L</sub></i> | too low<br><i>P<sub>L</sub></i> | too low<br><i>P<sub>L</sub></i> | too low<br><i>P<sub>L</sub></i> | too low<br><i>P<sub>L</sub></i> | too low<br><i>P<sub>L</sub></i> |
| ii.    | 2                         | 10  | too low<br><i>P<sub>L</sub></i> | too low<br><i>P<sub>L</sub></i> | too low<br><i>P<sub>L</sub></i> | too low<br><i>P<sub>L</sub></i> | too low<br><i>P<sub>L</sub></i> | too low<br><i>P<sub>L</sub></i> | 11                              | 10                              | too low<br><i>P<sub>L</sub></i> |
| iii.   | 3                         | 10  | 10                              | 14                              | 10                              | 10                              | 28                              | 10                              | 10                              | 10                              | 20                              |
| iv.    | 4                         | 10  | 10                              | 10                              | 10                              | 10                              | 10                              | 10                              | 10                              | 10                              | 10                              |
| v.     | 5                         | 10  | 10                              | 10                              | 10                              | 10                              | 10                              | 10                              | 10                              | 10                              | 10                              |

NOTE — Data used in this table originates from Table 12.

<sup>a)</sup> The *P<sub>L</sub>* given for the elements correspond to ppm, except for nitrogen, ash and moisture which are in weight percentages.

**Table 22 Number of Increments Per (Sub-) Lot for Grape Residue, Typical Mediterranean Materials with a Nominal Top Size of 16 mm**  
(Clause D-1)

| SI No. | Number of sub-lots        | Number of increments ( <i>n</i> ) per sub-(lot) <sup>a)</sup> |                            |                            |                              |                            |                           |                            |                              |                              |                             |
|--------|---------------------------|---|----------------------------|----------------------------|------------------------------|----------------------------|---------------------------|----------------------------|------------------------------|------------------------------|-----------------------------|
|        |                           | Moisture  | Ash                        | Al                         | Ca                           | Mg                         | Na                        | P                          | Si                           | K                            | N                           |
|        | ( <i>N<sub>SL</sub></i> ) | <i>P<sub>L</sub></i> = 1.5                                    | <i>P<sub>L</sub></i> = 1.0 | <i>P<sub>L</sub></i> = 150 | <i>P<sub>L</sub></i> = 3 500 | <i>P<sub>L</sub></i> = 200 | <i>P<sub>L</sub></i> = 50 | <i>P<sub>L</sub></i> = 200 | <i>P<sub>L</sub></i> = 1 000 | <i>P<sub>L</sub></i> = 1 500 | <i>P<sub>L</sub></i> = 0.10 |
| (1)    | (2)                       | (3)   | (4)                        | (5)                        | (6)                          | (7)                        | (8)                       | (9)                        | (10)                         | (11)                         | (12)                        |

|      |   |                  |    |    |                   |                  |     |                   |                  |                  |                   |
|------|---|------------------|----|----|-------------------|------------------|-----|-------------------|------------------|------------------|-------------------|
| i.   | 1 | too low<br>$P_L$ | 15 | 77 | too<br>low<br>$P$ | too low<br>$P_L$ | 162 | too<br>low<br>$P$ | too low<br>$P_L$ | too low<br>$P_L$ | too<br>low<br>$P$ |
| ii.  | 2 | too low $P_L$    | 10 | 10 | 11                | 10               | 17  | 7 989             | 10               | too low<br>$P_L$ | 18                |
| iii. | 3 | too low<br>$P_L$ | 10 | 10 | 10                | 10               | 10  | 10                | 10               | 10               | 10                |
| iv.  | 4 | 18               | 10 | 10 | 10                | 10               | 10  | 10                | 10               | 10               | 10                |
| v.   | 5 | 10               | 10 | 10 | 10                | 10               | 10  | 10                | 10               | 10               | 10                |

NOTE — Data used in this table originates from Table 13.

<sup>a)</sup> The  $P_L$  given for the elements correspond to ppm, except for nitrogen, ash and moisture which are in weight percentages.

### E-3 EXAMPLES OF CALCULATION OF THE NUMBER OF INCREMENTS FROM $V_{PT}$ , $V_i$ AND $N_{SL}$

The procedure for the determination of  $V_i$  and  $V_{PT}$  for a given lot is described in 7. Below examples of the calculation of the number of increments to be taken based on reference values of  $V_i$  and  $V_{PT}$  from the tables in Annex D are shown.

#### E-3.1 Example 1 — Determining The Minimum Number of Increments When Sampling a Seagoing Vessel Carrying Wood Pellets:

**E-3.1.1** A seagoing vessel is loaded with wood pellets from a large stockpile stored inside a warehouse. The pellets are taken from the stockpile with a front loader and put into a hopper feeding a conveyor belt running to the wharf. At the end of the conveyor belt, the material is dumped into a ship using a chute. The total amount to be loaded is 6 000 tonne. There is no mechanical sampler on the conveyor belt, which would have been the preferred method of sampling. The falling stream from the chute cannot be reached safely with a sampling tool. It was therefore decided that the normative method to be used in this case was sampling from a stockpile during reclaiming. Because of safety concerns, it was first agreed with the shipper that the front loader would be parked at a safe distance when increments from the freshly exposed surface were taken. Because a sub-lot for manual sampling can only be 2 500 tonne maximum (*see* 5.4), the 6 000 tonne lot was divided into three equal sub lots, each of approximately 2 000 tonne, for sampling and analyses.

It was decided that the final overall precision should be 0.25 weight percent for total moisture.

The minimum number of increments per sub-lot was calculated using the reference values of Annex D,  $V_i = 0.34$  (weight percent)<sup>2</sup> and  $V_{PT} = 0.002$  (weight percent)<sup>2</sup>; and applying equation (12):

$$n_{min} = \frac{4V_i}{N_{SL}P_L^2 - 4V_{PT}} = \frac{4 \times 0,34}{3 \times 0.25^2 - 4 \times 0,002} = 8 \text{ ----- (12)}$$

where

$n_{min}$  is less than the minimum number of increments per sub-lot (*see* 7.5), and therefore changed to  $n = 10$ .

$n_{min} = 10$  is the number of increments that should be taken from each of the three sub-lots. The increments from the individual sub-lots together form three combined samples. On each combined sample, a moisture measurement is performed and an average value is

calculated.

If ash content and gross calorific value are to be measured, the numbers of increments for these parameters shall be calculated individually as well, and the highest number shall be used.

For ash, with an agreed end precision of  $P_L = 0.20$  weight percent, and suggested values of  $V_i = 0.53$  (weight percent)<sup>2</sup> and  $V_{PT} = 0.015$  (weight percent)<sup>2</sup> (see Annex D) the above formula would give a minimum number of increments per sub-lot of  $n_{min} = 35$ .

For gross calorific value (db) an agreed end precision of  $P_L = 0.1$  MJ/kg and suggested values of  $V_i = 0.038$  (MJ/kg)<sup>2</sup> and  $V_{PT} = 0.0061$  (MJ/kg)<sup>2</sup> (see Annex D), the above formula would give a minimum number of increments of per sub-lot of  $n_{min} = 27$ .

This means that for the sample of each sub-lot on which total moisture, ash and gross calorific value shall be analyzed, a minimum of 35 increments for each of the three sub-lots shall be taken to comply with the minimum n of each parameter.

### **E-3.1.2 Improved Precision**

The setup is the same as above. If the overall precision for ash,  $P_L$  is changed to 0.15 weight percent (instead of 0.20 weight percent above) and suggested values of  $V_i = 0.53$  (weight percent)<sup>2</sup> and  $V_{PT} = 0.015$  (weight percent)<sup>2</sup> (see Annex D), equation 6 would give a minimum number of increments of  $n_{min} = 283$ .

This is not a very practical number. It can be decided to increase the number of sub-lots from 3 to 6, for example, meaning extraction of one sample per 1 000 tonne sub-lot. With  $N_{SL} = 6$  sub-lots, the number of increments would then drop to  $n_{min} = 28$  per sub-lot (a total of 168 increments from the entire lot).

### **E-3.2 Example 2 — Durability of Wood Pellets Delivered to a Power Plant by Lorries**

During a week, seven lorries will deliver 8 mm wood pellets to a power plant. Sampling needs to be done to determine a calculated average durability of the pellets of each lorry during this week. The total amount of pellets will be considered as the lot.

First, the calculations are done regarding the entire delivery as a single lot, with no division into sub-lots.

It is decided that the final overall precision for durability ( $P_L$ ) should be 0.20 weight percent (the suggested precision from Table 6). The minimum number of increments is calculated using the reference values of Annex D:  $V_i = 0.208$  (weight percent)<sup>2</sup> and  $V_{PT} = 0.0061$  (weight percent)<sup>2</sup>

The durability measurement shall only be performed on the *total* combined sample (composited from all the increments) collected during the entire week. The minimum number of increments would then be as equation 13:

$$n = \frac{4V_i}{NP_L^2 - 4V_{PT}} = \frac{4 \times 0.208}{(1 \times 0.20^2) - (4 \times 0.0061)} = 53 \quad \text{----- (13)}$$

where

$n_{min} = 53$  is the number of increments that should be taken during the entire week over the entire lot. This means, per lorry, a minimum number of samples of  $53/7 = 8$  increments shall be taken. The durability test is performed on the combined sample (composited from the 53 increments collected during the week). No weighted average is necessary.

If 53 increments, for instance, is considered too many to handle as a single combined sample (it may be too heavy to carry or similar), a new number of required sub-lots, with a chosen number of increments making up each combined sample (one for each sub-lot), can be calculated with equation 7. If it is decided to try to obtain a maximum of 20 increments per sub-lot,  $n_{MP}$ ,  $N_{SL}$  from ( $n_{MP} = 20$ ) gives:

$$N_{SL} = \frac{4(V_i + n_{MP}V_{PT})}{n_{MP}P_L^2} = \frac{4(0.208 + 20 \times 0.0061)}{20 \times 0.20^2} = 1.7 \text{ ----- (14)}$$

Now this value is rounded up to two sub-lots, which is used in equation 1, which now yields:

$$n_{min} = \frac{4V_i}{N_{SL}P_L^2 - 4V_{PT}} = \frac{4 \times 0.208}{2 \times 0.20^2 - 4 \times 0.0061} = 15 \text{ ----- (15)}$$

Using this approach, 15 increments shall be extracted from each of the two sub-lots (a total of  $2 \times 15 = 30$  increments over the entire lot).

Lastly, the lorries can each be considered as a sub-lot ( $N_{SL} = 7$  sub-lots).

In this case, each lorry will be sampled, the increments from each are composited and analyzed, yielding seven analysis results. The lot is the total of the seven lorries and the final overall precision is based on the entire lot of seven sub-lots.

$$n_{min} = \frac{4V_i}{N_{SL}P_L^2 - 4V_{PT}} = \frac{4 \times 0.208}{7 \times 0.20^2 - 4 \times 0.0061} = 3 \text{ ----- (16)}$$

Since 3 is less than the minimum number of increments,  $n_{min}$  should be set to 10 (see 7.5).

where

$n_{min} = 10$  is the number of increments that should be taken from *each* sub-lot; in this case, each lorry. On the combined sample of each sub-lot, the durability measurement is performed. At the end of the week, a weighted average is calculated based on the weight of each load. The average value is thus based on  $7 \times 10 = 70$  increments in total over the entire lot.

### E-3.3 Example 3 — Biofuel Production Facility

One supplier of logging residue delivers two lorry loads (40 tonne each) to a power station per day. The supplier would like to know the moisture content of the material that is transported from the production facility, and want to design a sampling scheme. The increment variance,  $V_i$ , is not known and should now be estimated. Until such an estimate can be achieved, the referenced values in Annex D are adopted to calculate the minimal number of increments,  $n_{min}$ .

$$P_L = 1.50 \text{ weight percent, } V_i = 10 \text{ (weight percent)}^2 \text{ and } V_{PT} = 0.73 \text{ (weight percent)}^2 \text{ ----- (17)}$$

Initially, the calculation is done without division into sub-lots ( $N_{SL} = 1$ ). In accordance with equation 1, the minimum number of increments is calculated:

$$n_{min} = \frac{4V_i}{N_{SL}P_L^2 - 4V_{PT}} = \frac{4 \times 10}{1 \times 1.50^2 - 4 \times 0.73} = -60 \text{ ----- (18)}$$



This number is negative, meaning that the final overall precision cannot be achieved without division into sub-lots.

Instead, the final overall precision is changed to  $P_L = 2.5$  weight percent. Now the calculation yields:

$$n_{min} = \frac{4V_i}{N_{SL}P_L^2 - 4V_{PT}} = \frac{4 \times 10}{1 \times 2,50^2 - 4 \times 0,73} = 12 \text{ ----- (19)}$$

There are 12 increments possible to use in practice.

**ANNEX F**  
*(Informative)*  
**SINGLE DELIVERY SAMPLING**

Lot

**Single delivery**



**Increments**

Portion of fuel extracted in a single operation of the sampling device

Combined sample

**Increment size based on nominal top size**

Examples: Saw dust 0,5 l, forest chips 3 l and hog fuel 5 l

Mixing and dividing

Size analysis sample

For the determination of particle size distribution or sample for BD (on field measurement).

Laboratory sample

**Laboratory sample size according to the determination needed.**

NOTE - Duplicate laboratory sample (s) may be divided.

Mixing and dividing

Test portion (s)

For determination to be done from unprepared sample material, e.g. bulk density, particle size distribution, fines in pellets, etc.

Air drying

— If needed (less than 31.5 mm for moisture analysis)

Crushing

Mixing and dividing

Mixing and dividing

Grinding

— at least less than 1 mm

General analysis sample

Mixing and dividing

**Test portions**

Test portions for the different determinations — size according to the demands of the determinations.

*Test report(s) of the properties determination, e.g. calorific value, ash content, sulphur content etc.*

**Annex G**  
*(Informative)*  
**CONTINUOUS DELIVERY SAMPLING**

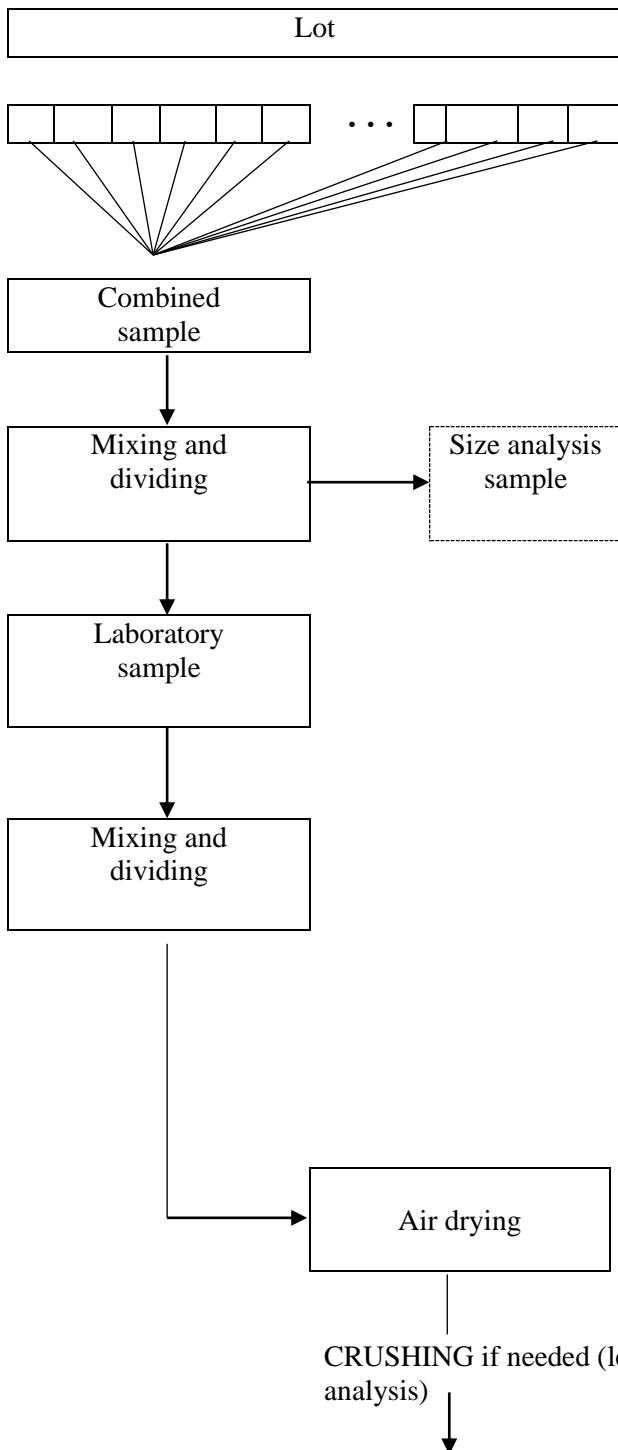

**Example of continuous delivery sampling scheme**

Principle: Moisture ( $M_{ar}$ ) is determined per daily delivery, properties of dry matter monthly

**Increments**

Portion of fuel extracted in a single operation of the sample device.

**Increment size based on nominal top size**

Examples: Saw dust 0,5 l, forest chips 3l and hog fuel 5l

For the determination of particle size distribution or sample for BD (on field measurement).

Example of laboratory sample size according to the determination needed

- moisture content ( $M_{ar}$ ), volume about 2l;
- bulk density; volume should exceed the measuring container volume by 30

NOTE — Duplicate laboratory sample (s) may be divided.

- size min. 2 l, test portion min. 300 g

Flow chart continues on the next page.

Air drying



Mixing and dividing



Grinding

- At least less than 1 mm
- At least 21



General Analysis sample

NOTE - Duplicate general analysis sample (s) may be divided, at least 0.5 l



Mixing and dividing



**Test portions**

Test portions for the different determinations  
— Size according to the demands of the determinations.

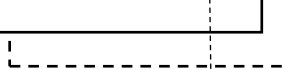

**Test report(s) of the properties determined,**  
Example: calorific value, ash content, Sulphur content etc.