

BUREAU OF INDIAN STANDARDS

DRAFT FOR COMMENTS ONLY

(Not to be reproduced without permission of BIS or used as an Indian Standard)

भारतीय मानक प्रारूप

औद्योगिक ट्रक – सुरक्षा आवश्यकताएँ और सत्यापन - भाग 1: स्व-चालित औद्योगिक ट्रक, चालक रहित ट्रकों के अलावा, चर-पहुंच वाले ट्रक और बोझ-वाहक ट्रक

*Draft Indian Standard*

**INDUSTRIAL TRUCKS — SAFETY REQUIREMENTS AND VERIFICATION — PART 1: SELF - PROPELLED INDUSTRIAL TRUCKS, OTHER THAN DRIVERLESS TRUCKS, VARIABLE - REACH TRUCKS AND BURDEN-CARRIER TRUCKS**

ICS: 53.060

**Transport Tractors, Trailors and Industrial Trucks  
Sectional Committee, TED 22**

**Last Date for Comments: 22.10.2022**

## NATIONAL FOREWORD

*(Formal clauses to be added later on)*

This standard is based on ISO 3691-1. The ISO 3691 series of standards covers safety requirements and their verification for industrial trucks as defined in ISO 5053.

This document is a type-C standard as stated in ISO 12100.

The machines concerned and the extent to which hazards, hazardous situations or hazardous events are covered are indicated in the Scope of this document.

When requirements of this type-C standard are different from those which are stated in type-A or B standards, the requirements of this type-C standard take precedence over the requirements of the other standards for machines that have been designed and built according to the requirements of this type-C standard.

The product needs to be designed in such a way that it is fit for its purpose or function and can be adjusted and maintained without putting persons at risk when used under the conditions foreseen by the manufacturer.

In order to properly design a product and to cover all specific safety requirements, the manufacturer will have to identify the hazards that apply to his product and carry out a risk assessment. The manufacturer will then need to design and construct the product taking this assessment into account.

The aim of this procedure is to eliminate the risk of accidents throughout the foreseeable lifetime of the machinery, including the phases of assembling and dismantling where risks of accidents could also arise from foreseeable abnormal situations.

In selecting the most appropriate methods, the manufacturer will need to apply the following principles, in the order given here:

- a) Eliminate or reduce risks as far as possible by design (inherently safe machinery design and construction);
- b) Take the necessary protective measures in relation to risks that cannot be eliminated by design;
- c) Inform users of any shortcoming of the protective measures adopted;
- d) Indicate whether any particular training is required;
- e) Specify any need to provide personal protection equipment; and
- f) Refer to the appropriate user's document for proper operating instructions.

Industrial trucks need to be designed to prevent foreseeable misuse wherever possible, if such would engender risk. In other cases, the instructions will need to draw the user's attention to ways shown by experience in which the machinery ought not be used.

This part of ISO 3691 does not repeat all the technical rules which are state-of-the art and which are applicable to the material used to construct the industrial truck. Reference will also need to be made to ISO 12100.

The composition of the Committee responsible for the formulation of this standard is given in Annex- XXX (to be added later)

Following clauses from ISO 3691-1 are modified in-order to bring them in line with Indian Condition and Infrastructure availability.

**Clauses modified:**

- 1) *Clause 4.1.4* — Reference to ISO 3691-7 & 8 has been removed and replaced with the content of ISO 3691-7.
- 2) *Clause 4.2.3.1* — Reference to ISO 3691-7 & 8 has been removed and replaced with the content of ISO 3691-7.
- 3) *Clause 4.2.3.2* — Reference to ISO 3691-7 & 8 has been removed and replaced with the content of ISO 3691-7.
- 4) *Clause 4.4.2.7* — Reference to ISO 3691-7 & 8 has been removed and replaced with the content of ISO 3691-7.
- 5) *Clause 4.6.1* — Reference to ISO 3691-7 & 8 has been removed and replaced with the content of ISO 3691-7
- 6) *Clause 4.6.3.6* – Content added from ISO 3691-7.
- 7) *Clause 4.7.4* — Reference to ISO 3691-7 has been removed and replaced with the content of ISO 3691-7 also reference of ISO 7096 added.
- 8) *Clause 4.7.7.1* — Reference to ISO 3691-7 has been removed and replaced with the content of ISO 3691-7 also reference of ISO 14120 added.
- 9) *Clause 4.8.1* — Reference to ISO 3691-7 has been removed and replaced with the content of ISO 3691-7
- 10) *Clause 4.10.1* — Visibility requirement modified
- 11) *Clause 4.11.2* — Reference to ISO 3691-7 has been removed and replaced with the content of ISO 3691-7.
- 12) *Clause 4.11.3* — Reference to ISO 3691-7 has been removed and replaced with the content of ISO 3691-7.
- 13) *Clause 4.11.4* — Electromagnetic Compatibility requirement is modified.

- 14) *Clause 6.2.1*— Reference to ISO 3691-7 has been removed and replaced with the content of ISO 3691-7.
- 15) *Clause 6.2.2* — Reference to ISO 3691-7 has been removed and replaced with the content of ISO 3691-7.

For conversion of pressure from bar to megapascal following to be used:

$$1 \text{ bar} = 0,1 \text{ MPa} = 0,1 \text{ N/mm}^2 = 10^5 \text{ N/m}^2.$$

For the purpose of deciding whether a particular requirement of this standard is complied with, the final value, observed or calculated expressing the result of a test or analysis, shall be rounded off in accordance with IS 2:2022 “Rules for rounding off numerical values (*revised*)”. The number of significant places retained in the rounded off value should be the same as that of the specified value in this standard.

*Draft Indian Standard*

**INDUSTRIAL TRUCKS – SAFETY REQUIREMENTS AND VERIFICATION:  
 SELF-PROPELLED INDUSTRIAL TRUCKS, OTHER THAN DRIVERLESS TRUCKS,  
 VARIABLE-REACH TRUCKS AND BURDEN-CARRIER TRUCKS**

**1 SCOPE**

It specified safety requirements and the means for their verification for the following types of self-propelled industrial trucks (hereafter referred to as *trucks*), as defined in ISO 5053.

- a) Industrial counterbalanced trucks;
- b) Reach trucks with retractable mast or retractable fork arm carriage;
- c) Straddle trucks;
- d) Pallet-stacking trucks;
- e) High-lift platform trucks;
- f) Trucks with elevating operator position up to 1 200 mm;
- g) Side-loading trucks (one side only);
- h) Lateral-stacking trucks (both sides), and lateral- and front-stacking trucks;
- j) Pallet trucks;
- k) Bidirectional and multidirectional trucks;
- m) Tractors with a drawbar pull up to and including 20 000 N;
- n) Rough-terrain counterbalanced trucks; and
- p) Industrial trucks powered by battery, diesel, gasoline or LPG (liquefied petroleum gas).

NOTE 1 — Trucks powered by CNG (compressed natural gas) are not dealt with. It is intended that CNG and other power sources to be addressed in future revisions of this standard.

For trucks with an elevating operator position of more than 1 200 mm and/or trucks designed to travel with an elevated load of more than 1 200 mm, this standard is intended to be used in conjunction with ISO 3691-3.

NOTE 2 — ISO 3691-3 is not applicable to counterbalanced fork lift trucks or trucks intended for container handling.

NOTE 3 — Some low-level order pickers with an elevating operator's position up to and including 1 200 mm lift height can be equipped with an additional lifting device to lift the load to a maximum lift height of 1 800 mm.

It is not applicable to self-propelled variable-reach trucks, driverless trucks or burden carriers.

It is not applicable to industrial trucks operating in severe conditions (for example, extreme climates, freezer applications, hazardous environments), where special precautions can be necessary.

It deals with all significant hazards, hazardous situations or hazardous events, as listed in **Annex B**, with the exception of the following, relevant to the applicable machines when used as intended and under conditions of misuse which are reasonably foreseeable by the manufacturer.

It does not establish requirements for hazards that can occur:

- a) During construction;
- b) When handling suspended loads that can swing freely;
- c) When using trucks on public roads;
- d) When operating in potentially explosive atmospheres;
- e) When using trucks in very narrow aisles with clearance of less than 500 mm to the racks;
- f) Arising from a non-ergonomic body attitude when driving sit-on trucks, load trailing;
- g) During travelling with unladen trucks having a rated capacity of more than 10 000 kg, due to visibility concerns; and
- h) Due to overload.

NOTE 4 — For the purposes of this standard, fork arms, load platforms and integrated attachments are considered to be parts of the industrial truck. Attachments mounted on the load carrier or on the fork arms which are removable by the user are not considered to be part of the industrial truck. Requirements for attachments are given in the appropriate clauses.

## 2. REFERENCE

The following standard contains provision which through reference in this text constitutes provision of this standard. At the time of publication, the edition indicated was valid. All standards are subject to revision and parties to agreements based on this standard are encouraged to investigate the possibility of applying the most recent edition of the standard indicated below:

<i>IS/ISO No.</i>	<i>Title</i>
ISO 2328:2007  IS 7525	Fork-lift trucks - Hook-on type fork arms and fork arm carriages - Mounting dimensions ;  Mounting Dimensions for Fork Carriers and Fork Arms for Forklift Trucks
ISO 2330 IS 6876	Fork-lift trucks - Fork arms - Technical characteristics and testing;  Technical Characteristics and Testing of Fork Arms for Forklift Trucks.
ISO 2867:2006  IS/ISO 2867	Earth-moving machinery - Access systems;  Earth-moving machinery - Access systems
ISO 3287:1999	Powered industrial trucks - Symbols for operator controls and other displays
ISO 3411:2007  IS 11115	Earth-moving machinery - Physical dimensions of operators and minimum operator space Envelope;  Earth-Moving Machinery - Human Physical Dimensions of Operators and Minimum Operator Space Envelope

ISO 3691-3	Industrial trucks - Safety requirements and verification - Part 3: Additional requirements for trucks with elevating operator position and trucks specifically designed to travel with elevated loads
ISO 3691-5:2009	Industrial trucks — Safety requirements and verification — Part 5: Pedestrian-propelled Trucks
ISO 3795:1989	Road vehicles, and tractors and machinery for agriculture and forestry — Determination of Burning behaviour of interior materials
ISO 5053 IS 4660	Powered industrial trucks — Terminology; Powered Industrial Trucks — Terminology
ISO 6055:2004 IS 7621	Industrial trucks — Overhead guards — Specification and testing; High-lift Rider Trucks — Overhead Guards and Testing
ISO 6292:2008 IS 9701	Powered industrial trucks and tractors — Brake performance and component strength; Powered Industrial Trucks and Tractors — Brake performance and Components Strength
ISO 12100:2010	Safety of machinery — General principles for design — Risk assessment and risk reduction
ISO 13284:2003 IS 15634	Fork-lift trucks — Fork-arm extensions and telescopic fork arms — Technical characteristics and strength requirements; Fork-lift trucks — Forks-arm extensions and telescopic fork-arm — Technical characteristics and strength requirements
ISO 13564-1	Powered industrial trucks - Test methods for verification of visibility. Part 1: Sit-on and stand-on operator trucks up to and including 10 t capacity
ISO 13849-1:2006	Safety of machinery — Safety-related parts of control systems — Part 1: General principles for design
ISO 13850:2006	Safety of machinery — Emergency stop — Principles for design
ISO 15870:2000 IS 15488	Powered industrial trucks - Safety signs and hazard pictorials - General principles; Powered Industrial Trucks - Safety Signs and Hazard Pictorials - General Principles
ISO 15871:2000 IS 15487:2004	Industrial trucks — Specifications for indicator lights for container handling and grappler arm Operations; Industrial Trucks — Indicator Lights for Container Handling and grappler arm operations.

ISO 20898: 2008	Industrial truck — Electrical requirements
ISO 21281: 2005	Construction and layout of pedals of self-propelled sit-down rider-controlled industrial trucks - Rules for the construction and layout of pedals
ISO 22915-1:2008	Industrial trucks — Verification of stability — Part 1: General
ISO 22915-2:2008  IS 4357	Industrial trucks — Verification of stability — Part 2: Counterbalanced trucks with mast;  Methods for Stability Testing of Fork Lift Trucks
ISO 22915-3:2008  IS 7309	Industrial trucks — Verification of stability — Part 3: Reach and straddle trucks; Reach and straddle forklift trucks — Method of stability test
ISO 22915-4:2009	Industrial trucks — Verification of stability — Part 4: Pallet stackers, double stackers and order-picking trucks with operator position elevating up to and including 1 200 mm lift height
ISO 22915-7:2009  IS 15640	Industrial trucks — Verification of stability - Part 7: Bidirectional and multidirectional Trucks;  BI — Directional multi-Directional Fork-Lift trucks - Stability tests
ISO 22915-8:2008  IS 7552	Industrial trucks — Verification of stability — Part 8: Additional stability test for trucks operating in the special condition of stacking with mast tilted forward and load elevated;  Industrial Trucks Operating in Special Conditions of Stacking with Mast Tilted Forward — Additional Stability Tests
ISO 22915-10:2008  IS 15514	Industrial trucks - Verification of stability - Part 10: Additional stability test for trucks operating in the special condition of stacking with load laterally displaced by powered devices ;  Industrial Trucks Operating in Special Conditions of Stacking with Load Laterally Displaced by Powered Devices - Additional Stability Test
ISO 22915-11  IS 15516	Industrial trucks — Verification of stability — Part 11: Industrial variable-reach trucks;  Industrial Variable-Reach Trucks - Stability Test
ISO 22915-20:2008	Industrial trucks — Verification of stability — Part 20: Additional stability test for trucks operating in the special condition of offset load, offset by utilization
ISO 22915-21:2009	Industrial trucks — Verification of stability — Part 21: Order-picking



IS 12726	trucks with operator position elevating above 1 200 mm ; Order picking trucks - Stability and stability test
ISO 24134:2006	Industrial trucks — Additional requirements for automated functions on trucks
ISO 24135-1:2006	Industrial trucks — Specifications and test methods for operator restraint systems. Part 1: Lap-type seat belts
IEC 60695-11-10:2003	Fire hazard testing — Part 11-10: Test flames — 50 W horizontal and vertical flame test methods
IS 10517	Acceptance criteria for forklift trucks
IS 11757	General requirements and acceptance criteria for forklift trucks with capacity from 10 000 kg to 50 000 kg
IS 10311	General requirements of powered platform trucks and their acceptance criteria
IS 10312	Safety code for powered tow trucks
ISO 14121-1: 2007,	Safety of machinery — Risk assessment — Part 1: Principles.

### 3 TERMS AND DEFINITIONS

For the purpose of this standard, the terms and definitions given in ISO 5053 and ISO 12100 and following shall apply

**3.1 Self-Propelled Industrial Truck** — Wheeled vehicle having at least three wheels with a powered driving mechanism, except for those running on rails, designed either to carry, tow, push, lift, stack or tier in racks any kind of load and controlled by an operator (3.7).

NOTE — See ISO 5053 for a comprehensive terminology.

**3.2 Pedestrian-Controlled Truck** — Truck designed to be controlled by an operator (3.7) walking with the truck by means of, for example, a tiller or remote control

NOTE — The truck may be equipped with a stand-on option.

**3.3 Ride-On Truck** — Truck designed to be controlled by an operator (3.7) riding on a seat or a driving platform on the truck

NOTE — Stand-on industrial trucks with a seat for the operator are considered as being stand-on trucks.

**3.4 Low-Lift Truck** — Truck having a lift height of 500 mm or less

**3.5 Bi-Directional Truck** — Truck designed to travel in either direction on a line parallel with its longitudinal axis, or perpendicular to this axis

**3.6 Multi-Directional Truck** — Truck designed to travel in any direction relative to its longitudinal axis

**3.7 Operator** — Designated person, appropriately trained and authorized, who is responsible for the movement and load handling of an industrial truck

NOTE 1 — Depending on the truck type, the operator can be riding on the industrial truck, on foot accompanying the truck (for example, tiller, cable-controlled) or remote from the truck (for example, remote radio-controlled).

NOTE 2 — National regulations can apply.

**3.8 Normal Operating Position** — Position in which the operator is able to control all functions for driving and load handling as defined by the manufacturer.

NOTE — Additional positions are permitted to be defined by the manufacturer if it is not possible to control all the functions of the truck from a single position. A rotating seat or stand-up end-control truck with more than one operating direction is considered as being or having a single operating position.

**3.9 Lift Height** — Vertical distance between the upper face of the fork blades or the lifting platform and the ground.

**3.10 Lift Height for Travelling** — Lifting height up to and including 500 mm providing sufficient ground clearance for travelling.

NOTE — It is identical to the maximum lift height for the stability test for travelling.

**3.11 Low Lift Height** — Maximum lift height up to and including 500 mm, where the vertical centre of gravity of the load does not exceed 1 100 mm above the ground.

**3.12 Automatically Acting Brakes** — Mechanical brakes which automatically apply in the non-travelling condition until released by the control of the operator.

**3.13 Lost Load Centre** — Horizontal shift in the standard load centre that may occur when removable attachments are added to a truck.

NOTE — For standard load centre, *see* Annex A.

**3.14 Actual Capacity** — Maximum load, expressed in kg, established by the manufacturer based on component strength and truck stability, that a truck can carry, lift and stack to a specified height, at a specified load centre distance and reach, if applicable, in normal operation.

NOTE — The actual capacity depends on the configuration of the truck, including variables such as the type and lift height of the mast fitted, the actual load centre and any attachments that might be fitted. This actual capacity defines the load-handling ability of the particular truck, as equipped. Additional actual capacity ratings with removable attachments can also be established where permitted by the appropriate stability tests or by calculation verified by empirical data.

**3.15 Rated Capacity** — Maximum load, expressed in kg, established by the manufacturer based on component strength and truck stability, that the truck can carry, lift and stack to the standard lift height and at the standard position of the centre of gravity.

NOTE 1 — For centre of gravity, *see* Annex A.

NOTE 2 — If the lifting height of the mast is lower than the standard lift height,  $H$ , the rated capacity is still assessed at the standard lift height.

NOTE 3 — The rated capacity is used to compare the capacity of different manufacturers' trucks and to provide the breakpoints used in technical standards and statistics. The operating limits for the truck are defined by its actual capacity.

## 4 SAFETY REQUIREMENTS AND/OR PROTECTIVE MEASURES

### 4.1 General

#### 4.1.1 Overall Requirements

The truck shall comply with the safety requirements and/or protective measures of this clause.

In addition, the truck shall be designed according to the principles of ISO 12100 for relevant but not significant hazards which are not dealt with by this document.

#### 4.1.2 Normal Climatic Conditions

For truck operation, the following climatic conditions apply:

- |   |               |
|---|---------------|
| a) Average ambient temperature for continuous duty:                                     | + 25 °C       |
| b) Maximum ambient temperature, short term (up to 1 h):                                 | + 40 °C;      |
| c) Lowest ambient temperature for trucks intended for use in normal indoor conditions:  | + 5 °C;       |
| d) Lowest ambient temperature for trucks intended for use in normal outdoor conditions: | - 20 °C; and  |
| e) Altitude:  | up to 2000 m. |

#### 4.1.3 Normal operating conditions

Normal operating conditions are the following:

- a) Driving (travelling and lifting) on substantially firm, smooth, level and prepared surfaces — the surface conditions on which the truck is designed to operate shall be specified in the instruction handbook (*see 6.2*);
- b) Driving with the horizontal load centre of gravity approximately on the longitudinal centre plane of the truck;
- c) Travelling with the mast or fork arms tilted backwards, where applicable, and the load in the lowered (travel) position.

If the above is not sufficient to allow the conditions for stability of a particular truck type to be specified, then the operating conditions shall be according to the standards referenced for stability in **4.8**.

#### 4.1.4 Electrical Requirements

Electrical requirements are as per ISO 20898: 2008

#### 4.1.5 Edges or Angles

There shall be no sharp edges or angles posing a hazard in the area of the operator in the normal operating position or in the area of access and egress during normal operation and daily checks.

#### 4.1.6 Stored Energy Components

Components which store energy and that would cause a risk during removal or disassembly, for example, hydraulic accumulator or spring-applied brakes, shall be provided with a means to release the energy before removal or disassembly.

## **4.2 Starting/Moving**

### **4.2.1 *Unauthorized Starting***

Trucks shall be provided with a device (for example, key, code, magnetic card) which prevents starting without its use.

Such devices for pedestrian-controlled and rider-controlled trucks manufactured by the same manufacturer shall not be interchangeable between the two truck types. Where devices, for example, magnetic cards, are destined for an individual operator, one device may be used on both truck types but shall not allow starting by unauthorized persons.

### **4.2.2 *Unintended Movement and Inadvertent Activation***

Truck movement from the holding position, other than by actuation of the controls by the operator, due to drift or creep (for example, by leakage), shall be avoided.

#### **4.2.2.1 *Parking brakes***

A parking brake complying with **4.3.1** shall be provided.

For sit-on rider trucks, the parking brake system should be manually operable by hand or foot from the normal operating position or automatically applied by leaving the normal operating position. Trucks with only non-automatically applied parking brake(s) shall have a warning to the operator to apply the brakes before leaving the truck.

Failure of the control system of an automatically applied parking brake shall be indicated to the operator.

#### **4.2.2.2 *Internal-combustion-engine powered trucks***

Internal-combustion-engine powered trucks shall be fitted with a device which prevents the engine being started while the transmission is engaged.

#### **4.2.2.3 *Travel controls***

Travel controls on internal-combustion-engine powered trucks shall be so arranged that on level ground the truck will not move from rest until the transmission has been engaged.

#### **4.2.2.4 *Powered travel movement***

Powered travel movement of the truck with a ride-on operator shall be possible only if the operator is in the normal operating position.

Powered travel shall not occur automatically when the operator returns to the normal operating position without an additional operation, for example, by requiring a resetting of the direction control or reactivation of the speed control.

#### **4.2.2.5 *Manual gearbox and manually operated clutch pedal***

A truck with an automotive-type manual gearbox and manually operated clutch pedal satisfies the requirements of **4.2.2.2** and **4.2.2.4**.

### **4.2.3** *Travel Speed*

#### **4.2.3.1** *Pedestrian-controlled trucks*

Single-speed pedestrian-controlled trucks operating on level ground shall not exceed a travel speed of 4 km/h and an acceleration of 0.5 m/s<sup>2</sup> and shall be designed for low-lift only.

Variable-speed pedestrian-controlled trucks operating on level ground shall be controllable by the operator to be aligned with their walking speed.

The travel speed of variable-speed pedestrian-controlled trucks operating on level ground shall not exceed 6 km/h.

#### **4.2.3.2** *Stand-on trucks and pedestrian-controlled trucks with foldable platform*

The maximum speed on level ground of stand-on trucks and pedestrian-controlled trucks fitted with a foldable platform when the operator is on the platform shall not exceed 16 km/h.

a) For trucks with a foldable operator platform, *see* **4.7.3.3**.

b) For trucks with stand-on options, *see* **4.7.3.2** and **4.7.3.4**.

#### **4.2.3.3** *Travel with mast raised*

Travel with mast raised is subject to regional requirements.

## **4.3 Brakes**

### **4.3.1** *General*

All industrial trucks shall be designed with service and parking brakes. Brakes shall comply with ISO 6292

The parking brake shall be equipped with a system preventing unintentional release. The parking brake force shall be applied by mechanical means.

The parking and service brakes of trucks that can travel with an elevated operator position and/or elevated load above 500 mm, and up to and including 1 200 mm, are subject to the following requirements:

- a) For travel speeds up to and including 9 km/h, parking brakes shall be in accordance with **6.1.2 (a)** of ISO 6292 and service brakes shall comply with the specification given in Table 2 Group C of ISO 6292;
- b) For travel speeds above 9 km/h, parking brakes shall be in accordance with **6.1.2 (b)** of ISO 6292 and service brakes shall comply with the specifications given in Table 2, Group A1 of ISO 6292.

### **4.3.2** *Failure of Energy Supply to Service Brake*

Failure of the energy supply to the service brake shall not result in a total loss of braking and shall enable a controlled stop.

### **4.3.3** *Stand-On and Pedestrian-Controlled Trucks*

Stand-on and pedestrian-controlled trucks shall be equipped with a brake system that will automatically engage upon release of the brake actuating control by the operator. This system may serve as the service and parking brake.

#### **4.4 Manual Control Actuators**

##### **4.4.1 General**

###### **4.4.1.1 Consistency with the truck motions**

Movement of these controls shall be consistent with the motions of the truck being operated, wherever practicable. They shall be confined within the plan view outline of the truck or tiller.

###### **4.4.1.2 Multiple operators**

If additional operating positions are fitted, for example, for more than one operator, the operation of these controls shall only be possible from one operating position at a time, excepting the emergency disconnect switch, which shall be operable from all positions.

###### **4.4.1.3 Multiple operating positions**

If more than one operating position is fitted for a single operator, the use of the controls for one of these operating positions shall preclude the use of the controls of another operating position. The exception to this is the emergency disconnect switch, which shall be operable from all positions.

##### **4.4.2 Travel and Braking Controls**

###### **4.4.2.1 General**

The motion of the speed operating control shall be so designed that an increase in the movement of the control increases the travel speed. When the control is released, it shall return to the neutral position of the control actuator.

###### **4.4.2.2 Sit-on trucks**

Trucks with pedal-operated travel and braking controls shall comply with ISO 21281.

###### **4.4.2.3 Stand-on trucks**

The requirements for travel and braking controls for a stand-on truck are as follows.

###### **a) Travel control functions:**

- i) Where a tiller is used, it shall be fitted with control devices for travel direction and speed; and
- ii) Where a steering wheel or similar control is used, the controls for travel direction and speed shall be positioned in close proximity to the steering control.

The service brake function shall be engaged

- i) Automatically when the tiller is released, if operated by the tiller;
- ii) Automatically when the travel-control is released, if operated by the travel-control;

- iii) Automatically when releasing the pedal, if the brake function is foot-operated; and
- iv) When activating the hand actuator, if the brake function is hand-operated.

b) Trucks with elevating operator platform up to 1 200 mm.

Means shall be provided to prevent travel while the platform is elevated more than 500 mm, unless the controls are elevated with the platform.

#### **4.4.2.4 Pedestrian-controlled trucks**

The requirements for pedestrian-controlled trucks are as follows.

- a) The tiller shall be fitted with control devices for travel direction and speed;
- b) When the tiller is released, it shall automatically return to its upper rest position, cut off traction power in the travel direction and engage the brake;
- c) When the tiller is in its lowered position, the traction power in the travel direction shall be cut off and the brake shall be engaged; and
- d) The tiller shall be fitted with a device to energize the direction of travel away from the operator until pressure on the device is relieved, or that stops the truck by applying the brakes, if the head of the tiller in its operating position comes into contact with a solid body (for example, the operator's body).

#### **4.4.2.5 Differential locking**

It shall be possible to unlock the differential when the truck is moving.

For trucks fitted with a pedal-operated differential lock, depression of the pedal shall lock the differential and shall be released when releasing the pedal.

#### **4.4.2.6 Additional operation from outside the truck**

If travel control from outside the truck is provided for the operator of sit-on or stand-on trucks and tractors, when operated from the outside the travel speed shall be limited to 6 km/h. These controls may be attached to the truck or a remote control may be provided, and the operating system shall be made operable by means of a separate switch or automatically when the operator leaves the normal operating position.

a) General

- i) If the control actuator is released, the drive unit shall switch off automatically and the brake shall be engaged automatically. Simultaneous operation from the operating positions shall be excluded; and
- ii) Controls fitted at the outside of the truck shall be secured against unintentional activation.

b) Additional requirements for cable-connected remote controls

- i) The length and layout of the cables shall allow the operator to operate from outside of the area of hazard of the truck and have visibility of the path of travel. It shall not be possible for the cable to become entangled with the wheels; and

ii) On a portable control panel, the control elements, with the exception of the emergency stop, shall be guarded against unintentional operation. The portable control panel shall be fitted with an emergency stop device in accordance with ISO 13850.

c) Additional requirements for cable less control

i) The transmission range shall be adequate to allow the operator to operate from outside the area of hazards of the truck and have visibility in the path of travel;

ii) On the portable control panel, the control elements for operation, with the exception of the emergency stop, shall be guarded against unintentional operation;

iii) The reliability level shall be at least 10<sup>-9</sup> and the Hamming distance shall be 2. The remote control shall be in accordance with ISO 13849-1, performance level (PL) c;

iv) The truck shall stop automatically when outside of the operator's direct view (90°) and/or out of range of the remote control; and

v) No control interference shall be possible when more than one truck is operating under remote control at the same time.

d) Additional requirements for trucks with trailer coupling:

i) The controls (e.g. rear touch device) shall be arranged so that the operator does not have to step between the truck and the trailer in order to operate them;

ii) The rear touch device shall be secured against unintentional operation;

iii) During operation of the rear touch device, the travel speed of the truck shall not exceed 2.5 km/h.

**4.4.2.7** *Additional operation from alongside pedestrian-controlled and stand-on trucks (coasting)*

The additional operation of pedestrian-controlled and stand-on trucks while the operator is walking alongside the truck shall only be possible with the truck's fork arms trailing.

The additional operation of such trucks while the operator is walking alongside the truck, and the use of low-lift order-picking trucks provided with a system that allows for operation while walking alongside the truck, are subject to following requirements:

a) Activation of the travel control device from outside of the truck shall only be possible when the truck is stationary;

b) The travel control shall be a hold-to-run control and the speed shall not exceed 4km/h while operating the travel control from outside of the truck; and

c) The braking function shall be automatically applied when travel control device is released.

**4.4.3** *Steering Controls*

**4.4.3.1** *Steering direction*

The following applies:



- a) For stand-on or sit-on trucks, when travelling in the forward direction, clockwise rotation of the steering wheel, or equivalent movement of the steering control, shall steer the truck to the right;
- b) For trucks with an operator control position rotatable by more than 90°, or having duplicated control positions, in order to facilitate the operator facing in the opposite direction, clockwise rotation of the steering wheel, or equivalent movement of the steering control, shall steer the truck to the right as viewed from the new position, that is, the steering control sense is reversed beyond 90° to facilitate the operator facing in the opposite direction;
- c) Trucks with continuous 360° steering, that is, the steering/drive wheel can move through 360° to propel the truck in the direction selected by the steering control, shall operate in the same sense as **4.4.3.1(a)**, above, when travelling in the forward direction.
- d) For pedestrian-operated trucks fitted with a tiller, when travelling in the forward direction, clockwise movement of the tiller shall steer the truck to the right.
- e) Exceptionally, when requested by the user, end-control trucks may be equipped with reverse steering, that is, clockwise rotation of the steering control will steer the truck to the left. Such trucks should be clearly identified.

#### **4.4.3.2** *Failure of power supply*

In the event of an interruption of the power supplied to the steering system (including a dead motor or engine), it shall be possible to maintain the path being steered until the truck is brought to a controlled stop.

#### **4.4.4** *Load-Handling Controls*

##### **4.4.4.1** *Controls*

Controls shall return to the neutral position when released and stop the corresponding load movement. When single levers are used to control a function on trucks other than reach trucks with retractable mast or forks, the lever closest to the operator shall control lifting and lowering, the second closest lever should control the tilt function, the third closest lever should control the side shift and the fourth closest lever should be for auxiliary functions.

When single levers are used to control a function on reach trucks with a retractable mast or forks, the lever closest to the operator shall control lifting and lowering, the second closest lever should control the displacement of the mast or forks, the third closest lever should control the tilt function, the fourth closest lever should control side shift and the fifth closest lever should be for auxiliary functions.

Trucks equipped with attachments which hold the load by power (for example, paper clamp) shall feature control(s) with a secondary action to prevent unintentional release of the load.

#### **Table 1 Levers or Handle-Type Controls with Single Operation, Sequence of Location and Direction of Movement**

Function (listed in sequence of location)	Direction of movement	
	Motion of load or equipment	Predominant motion of operator's hand when actuating control handle while facing load
Hoist	Up	Rearward or up
	Down	Forward or down
Reach	Retract	Rearward
	Extend	Forward
Tilt	Rearward	Rearward or up
	Forward	Forward or down
Side shift	Right	Rearward or up
	Left	Forward or down
Push-pull	Rearward	Rearward
	Forward	Forward
Rotate laterally	Clockwise	Rearward or up
	Counter clockwise	Forward or down
Rotate longitudinally	Rearward	Rearward or up
	Forward	Forward or down
Load stabilizer	Down	Rearward or up
	Up	Forward or down
Fork position	Together	Rearward or up
	Apart	Forward or down
Grip	Engage	Rearward or up
	Release	Forward or down
Truck stabilizer	Raise	Rearward or up
	Lower	Forward or down
Clamp	Clamp	Rearward or up
	Release	Forward or down

#### 4.4.4.2 Manual-lift systems

The hand power forces and the layout of controls of manually operated lifting systems shall comply with ISO 3691-5.

#### 4.4.5 Multi-Function Controls

Where a control is designed and constructed to perform more than one function, each separate function shall be clearly marked. Each control function shall return to the neutral position when released and stop the corresponding load movement.

#### 4.4.6 Controls for Automated Functions

The controls for automated functions shall comply with ISO 24134.

#### 4.4.7 Marking

Graphic symbols used for marking controls shall comply with 6.3.1.4.

### 4.5 Power Systems and Accessories

#### 4.5.1 Exhaust and Cooling Systems

##### 4.5.1.1 Exhaust systems

The exhaust system shall be designed in accordance with 4.7.6 and such that engine exhaust is directed away from the operator position. Materials used in the vicinity of exhaust systems shall be non-flammable and shall be chosen and protected such that they are not adversely affected by heat from the exhaust system.

##### 4.5.1.2 Cooling systems

The air flow through the cooling system shall be arranged so as to avoid discomfort to the operator.

## **4.5.2 Fuel Tank**

### **4.5.2.1 Tank isolation**

If a fuel tank is within or adjacent to the engine compartment and excessively high temperatures can occur, the tank and/or filling arrangement shall be isolated from the electrical and exhaust systems by suitable protection, for example, a separate enclosure or baffles. The tank location and facilities for filling shall be such that spillage or leakage will not drain into the engine or operator's compartment or onto electrical or exhaust system parts.

### **4.5.2.2 Fuel spillage**

Fuel spillage shall not be possible under normal operating conditions.

## **4.5.3 Access to Engine and Other Compartments**

### **4.5.3.1 Engine covers**

An enclosed engine compartment shall satisfy fan guarding requirements when the manufacturer's recommended routine maintenance is performed with the engine off. If a fan can start (for example, temperature switch) when the engine is off, the fan shall be guarded. A safety warning sign shall be provided, and included in the instruction handbook (*see* 6.2). Warnings shall comply with 6.3.3.4.

Access from underneath is considered guarded if the access ground clearance is less than 600 mm between the underside of the truck and level ground.

### **4.5.3.2 Unintentional closure**

Where unintentional closure could cause injury, access covers (for example, traction battery or engine covers) shall be provided with means for preventing unintentional closure. Those means shall be permanently affixed to the truck or stored in a safe place on the truck.

## **4.5.4 Liquefied Petroleum Gas (LPG) - Powered Trucks**

### **4.5.4.1 Containers**

The following applies to the containers of trucks powered by LPG:

- a) LPG containers shall be either permanently fixed to the truck or removable;
- b) When LPG containers are removable, their fastenings shall permit easy handling and checking of the installation after the exchange of containers;
- c) Removable LPG containers that incorporate a pressure-relief valve shall be so positioned on the truck that the pressure-relief valve opening is always in communication with the vapour space at the top of the container. This may be accomplished, for example, by an indexing pin which positions the container when the container is properly installed;
- d) LPG containers shall be securely mounted to the truck to prevent movement. Fastening shall withstand static loading of four times the filled container weight in any direction without permanent visible deformation;

- e) LPG containers shall be fitted on the truck such that exposure to abrasion, shock and the corrosive action of the products handled by the truck is reduced;
- f) LPG containers and their connections shall be installed such that there are no projections outside the plan view outline of the truck;
- g) If LPG containers are installed in a compartment, this compartment shall have permanent openings at the bottom. The total surface area of these ventilation openings shall be at least 200 cm<sup>2</sup> allowing adequate ventilation to outside the truck;
- h) If an additional LPG container is carried on the truck, it shall be secured in the same manner as the main container;
- j) LPG containers, whether fixed or removable, shall be equipped with a device to prevent unintentional emission of gas or liquid, for example, in the case of a pipe system failure. This does not apply to pressure-relief valves;
- k) Pipe fittings and accessories on LPG containers shall be protected against mechanical damage when used as specified by the manufacturer;
- m) The fuel take-off on the LPG container shall be equipped with an easily and quickly accessible manually operated valve. The position and method of operation of this valve shall be clearly marked on the valve handle or on the outside of the truck near the valve;
- n) The fuel take-off shall be in a liquid form, unless the LPG container and engine are specially equipped for a direct vapour withdrawal;
- p) Permanently mounted LPG containers to be filled by the user shall be fitted with the following:
  - 1) A pressure-relief valve connected to the vapour space of the container that, when fitted inside the compartments of trucks, shall have the discharge side of the relief valve piped to the atmosphere away from the operator and that shall comply with **4.5.4.3 (d)**;
  - 2) An 80 % fill stop valve; and
  - 3) Maximum liquid level devices suitable for the LPG in use, indicating the maximum product level and which shall not vent to the atmosphere.
- q) LPG containers shall be positioned such that they are not exposed to the damaging effects of heat, particularly heat from the engine or the exhaust system. If it is necessary to fit a heat shield, this shall not inhibit ventilation.

#### **4.5.4.2 Piping**

The following applies to the piping used on trucks powered by LPG:

- a) Connecting piping and all associated parts shall be easily accessible, protected against excessive heat radiation, damage and wear, and shall be flexible enough to withstand vibration and deformation in service, as follows:
  - i) Piping shall be so arranged that damage or leaks are easily detectable and that checks and maintenance can be carried out;

- ii) Piping shall be installed such that it cannot be damaged by any excessive heat radiation from hot parts of the truck;
  - iii) Fully rigid pipes shall not be used for connecting the container to equipment on the engine; and
  - iv) Piping shall be so arranged that there are no projections outside the plan view outline of the truck.
- b) Pressure hoses operating above 1 bar shall be supported at least every 500 mm. Rigid pipes shall be supported at least every 600 mm.
  - c) Hoses, pipes and all connections operating at pressures above 1 bar shall be suitable for a working pressure of 25 bar and shall withstand without bursting a test pressure of 75 bar. Hoses, pipes and all connections operating below 1 bar shall withstand without bursting a test pressure of five times the maximum working pressure.
  - d) Pressure shall not exceed the working pressure rating of components in any section of pipe work containing LPG in liquid form between two shut-off valves that are closed; a pressure-relief valve, for example, or other suitable means, may be used if necessary.
  - e) Aluminium piping shall not be used.
  - f) Hoses shall be as short as practical.
  - g) Pressure unions and joints operating above 1 bar shall be made of metal, except for any constrained sealing washers.

#### 4.5.4.3 Equipment

The following applies to the equipment used on trucks powered by LPG.

- a) The supply of gas shall be automatically cut off when the engine stops, irrespective of whether or not the ignition system has been switched off;
- b) For multi-fuel applications, the system shall be designed to avoid the possibility of LPG entering any other fuel container and to shut off each fuel source before the alternative one is opened;
- c) If the truck is equipped with two or more containers to supply fuel, they shall be connected via a multi-way valve or other suitable means, so that LPG can only be drawn from one container at a time. The use of two or more containers at the same time shall not be possible;
- d) Pressure-relief valves or liquid-level indicators shall be installed such that they cannot discharge in the direction of the operator or onto truck components that could be a source of ignition;
- e) If corrosion of a part would interfere with its proper functioning, that part shall be provided with a corrosion-resistant protective coating;
- f) All fuel system components shall be firmly secured to the truck;
- g) Pressure-reducing valves shall be readily accessible for inspection and maintenance; and
- h) The engine compartment shall be designed in accordance with **4.5.4.1(g)**, in order to avoid any LPG accumulation.

#### 4.5.4.4 Regional requirements

LPG-powered trucks are subject to regional requirements, additional to the requirements of this part of ISO 3691.

### 4.6 Systems for Lifting and Tilting

#### 4.6.1 Lift Chains

The truck or mast manufacturer shall have on record a certificate from the chain manufacturer giving the breaking load of the chains used.

When the lifting mechanism includes a chain or chains, the truck manufacturer shall only use leaf or roller chains. These shall provide a minimum factor,  $K_1$ , when supporting the maximum capacity load and assuming no friction in the mast structure, which is given by the following equation:

$$K_1 = (L_c \times n) / (R + w)$$

where

$K_1$  = safety factor of the lifting mechanism;

$L_c$  = minimum breaking load for new chain;

$n$  = number of chains;

$R$  = maximum load capacity of the truck; and

$w$  = dead weight of the lifting mechanism supported by the chains.

The  $K_1$  factor shall be:

- 1) for trucks  $\leq 10000$ kg rated capacity  
 $K_1 \geq 5$
- 2) for trucks  $> 10000$ kg rated capacity  
 $K_1 \geq \{5 - 0.2(Q - 10)\}$  but not less than 4

Where  $Q$  is rated capacity of the truck, in tonnes.

Pulley diameters shall be in accordance with the chain manufacturer's instructions.

#### 4.6.2 Mechanical Lifting Systems

##### 4.6.2.1 General

The lifting system shall comply with the requirements of **4.6.3.3**.

##### 4.6.2.2 Failure of lifting/lowering mechanism

In the event of failure of a single lifting/lowering part of the mechanism (for example, gearwheel, chainwheel or spindle), it shall not cause the elevated load or operator's platform to descend uncontrolled.

##### 4.6.2.3 Lowering speed

The lowering speed of the lifting mechanism with its rated load shall not exceed 0.6 m/s.

### **4.6.3 Hydraulic Lifting and Tilting Systems**

#### **4.6.3.1 Hydraulic lifting systems**

The hydraulic lifting system shall be designed such that, with the hydraulic fluid at normal operating temperature, the mast substantially vertical and carrying rated capacity load, the descent of the load caused by internal leakage in the first 10 min shall not exceed:

- a) 100 mm for trucks up to and including 10 000 kg rated capacity; and
- b) 200 mm for trucks over 10 000 kg rated capacity.

#### **4.6.3.2 Lowering speed limitation**

A device shall be incorporated in the lift circuit which, in the event of a failure of the hydraulic circuit, excluding the hydraulic lift cylinder(s), shall restrict the rate of descent of the lifting mechanism with its rated load to 0.6 m/s maximum. The device shall be fitted directly at the lifting cylinder(s).

#### **4.6.3.3 Limitation of stroke**

The lift assembly shall be fitted with a positive means to prevent over-travel. In addition, positive means (for example, mechanical stop) shall be provided to prevent the fork carrier and moving elements of the mast structure from unintentionally disengaging from the upper end of the mast.

#### **4.6.3.4 Hydraulic tilting systems**

The internal leakage rate of the complete hydraulic tilting system (that is, cylinder, valve, etc.), with the oil at normal operating temperature, shall allow no more than 5° forward movement of the mast in 10 min from the vertical mast position, when the rated load is at a height of 2 500 mm or, in the case of trucks with lift heights less than 2 500 mm, at their maximum lift height. The average tilting speed allowed by internal leaks shall not exceed 0.5°/min for trucks with a maximum forward tilt of less than 5°.

#### **4.6.3.5 Mast tilt and carriage isolation**

For ride-on trucks, mast tilt and carriage movement shall not be possible through operation of the primary load-handling control when the operator is not in the normal operating position.

#### **4.6.3.6 Isolation of attachment movement**

For ride-on trucks, the movement of powered attachments shall not be possible through operation of the control when the operator is not in the normal operating position.

### **4.6.4 Hydraulic Systems**

#### **4.6.4.1 Hydraulic circuits**

Hoses, piping and connections subjected to internal pressure shall be capable of withstanding, without bursting or permanent deformation, a pressure equal to at least three times the operating pressure. Pipes and hoses shall be located and, if necessary, restrained, so that deterioration, sharp edges and other damage-causing sources are minimized.

#### **4.6.4.2 Pressure controls**

All hydraulic systems shall include a device which prevents the pressure in the system from exceeding a preset level. The device shall be so designed and fitted that unintentional loosening or adjustment is avoided and so that a tool or key is required to alter the pressure setting.

#### **4.6.4.3** *Failure of energy supply to hydraulic circuits*

In the case of a fault or interruption of the supply of energy, the design of the hydraulic system shall be such that it does not allow any uncontrolled motion of equipment or attachment.

#### **4.6.4.4** *Fluid purification*

The hydraulic system(s) shall be protected against the risk of contamination of the hydraulic fluid, for example, by means of magnet(s) or filter(s).

#### **4.6.5** *Load-handling and -stacking attachments*

##### **4.6.5.1** *Unintentional displacement or detachment*

Means shall be provided to prevent the unintentional lateral displacement or unintentional detachment of attachments from the truck. Movement of the attachment and its parts shall be mechanically limited at the extreme positions.

##### **4.6.5.2** *Malfunction in the power supply system*

Attachments that hold the load by power shall be designed such that the maximum load they are intended to handle is automatically retained for at least 10 min when the truck's manual controls are in the neutral position or in the event of a malfunction in the power supply system for the attachment.

##### **4.6.5.3** *Hydraulic system for attachment*

If an attachment has its own separate hydraulic system, it shall comply with **4.6.4**.

##### **4.6.5.4** *Combined hydraulic systems*

If an attachment has a hydraulic system connected to the truck hydraulic system, the two systems shall be compatible and the combined systems shall comply with **4.6.4**.

##### **4.6.5.5** *Attachments for lifting freight containers*

An attachment for lifting freight containers shall be equipped with indicator lights according to ISO 15871. The attachment shall have a device(s) to prevent unintentional disengagement of a container. Means shall be provided to prevent lifting of the container for transport unless all interface mechanisms are fully engaged and locked. If multiple containers are lifted at the same time, the same requirements are valid for all containers.

Travel speed shall be restricted to a maximum of 10 km/h if the container is not locked to the attachment in a manner that will prevent unintentional drop (for example, lifting with grapple arms).

##### **4.6.5.6** *Fork arms*

**4.6.5.6.1** Solid-section fork arms shall be manufactured and tested in accordance with ISO 2330, except with respect to safety factors.



**4.6.5.6.2** The total capacity of all fork arms fitted to a truck shall not be less than the actual capacity of the truck.

**4.6.5.6.3** Means shall be provided to prevent unintentional lateral displacement of the fork arms on the fork carrier.

**4.6.5.6.4** Fork-arm extensions shall be designed to prevent accidental disengagement from the fork arms, and shall be in accordance with ISO 13284.

#### **4.6.5.7 Fork carriers**

Hook-on type fork carriers shall be in accordance with ISO 2328.

### **4.7 Operator Positions**

#### **4.7.1 Dimensions**

The operator's seat or standing position shall be so located that the operator has sufficient room while operating the truck so as to remain within the plan view outline of the truck. The dimensions shall be of suitable and ergonomic shape to accommodate at least a 5th percentile to a 95th percentile of the population, as shown in ISO 3411, (*see* Fig. 1 to 3) within the plan view outline of the truck. The seat shall not extend beyond the plan view outline of the truck.

The minimum distance from the top edge of the seat back to the plan view outline shall be 50 mm (*see* Fig. 1 and 2).

For stand-on pedestrian- and centre-controlled ride-on trucks employing a tiller, the tiller steering control movement may extend beyond the plan view.

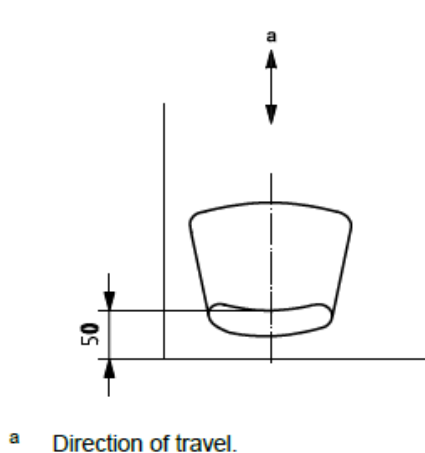

All Dimensions in millimetres.

FIG. 1 FRONT-SEATED OPERATOR

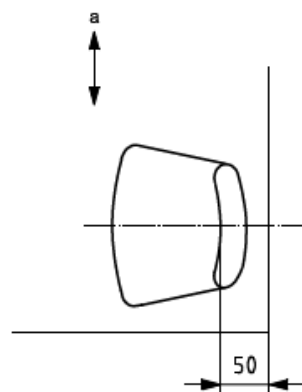

FIG. 2 SIDE-SEATED OPERATOR

#### **4.7.2 Operator Access and Egress**

##### **4.7.2.1 General**

Trucks shall be designed to permit safe and easy access and egress and to minimize the risk of slipping, falling and tripping. Steps, running boards and hand holds (grab handles, fixed parts of the truck structure, etc.) shall be provided above a step height of 350 mm to give three-point contact at all heights (that is, one

hand and two feet or two hands and one foot). Step width, instep clearance and toe clearance shall comply with ISO 2867.

#### 4.7.2.2 Steps

Steps shall have slip-resistant surfaces or covering (for example, expanded metal, abrasive coating). The first step shall be not more than 550 mm from the ground and succeeding steps shall be 250 mm to 350 mm, preferably at equal intervals.

#### 4.7.2.3 Compartment floors

The compartment floor frequented by the operator, steps and walkways shall be free of obstacles and shall have a slip-resistant surface, for example, ribbed mats, abrasive coating, expanded metal.

#### 4.7.2.4 Walkways

Walkways more than 2 000 mm from the ground shall have guard rails. The guard rails shall have a height of 900 mm to 1 100 mm and shall be capable of withstanding, without permanent deformation, a force of 900 N applied in a horizontal direction from the inside to the outside.

#### 4.7.2.5 Hand holds

For access to, and egress from, the normal operating position with a floor height above 300 mm, hand hold(s) shall be provided; these may be part of the truck structure. The clearance dimension for a hand hold shall be at least of 45 mm width, 130 mm length and diameter of 15 mm (see Fig. 3).

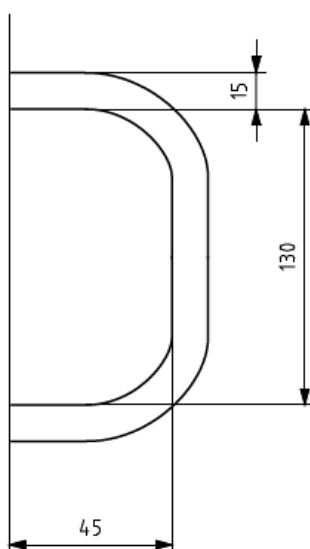

All Dimensions in millimetres.

FIG. 3 HAND HOLD

### 4.7.3 Platforms

#### 4.7.3.1 General

Operator stand-on platforms on pedestrian-controlled and stand-on end-controlled trucks shall be dimensioned in accordance with 4.7.1 and shall be capable of withstanding a compression force corresponding to 2.5 times the mass of the laden truck applied along the longitudinal axis of the truck with

the outer most projection of the platform against a flat vertical surface. For the purpose of this requirement, the operator platform includes any surrounding reinforcement or parts of the truck which provide resistance to crushing of the platform, except for pedestrian-controlled stand-on trucks employing a tiller.

#### **4.7.3.2** *Platforms overhanging the truck chassis*

Platforms overhanging the truck chassis on tiller-operated stand-on trucks, capable of travelling more than 6km/h, shall, in addition to **4.7.3.1**, be provided with a guard at either the sides or the front of the platform. The guards shall be capable of withstanding a horizontal force of 900 N acting from inside to outside applied in line with the centre of the operator's standing position without permanent deflection. The side guards shall be at a minimum height of 700 mm above the platform in its protective position.

#### **4.7.3.3** *Pedestrian-controlled trucks with foldable platforms*

Operator stand-on platforms that are fitted to pedestrian-controlled trucks and overhang the truck's chassis may be capable of being folded or pivoted to an upright position when the operator leaves the platform; this may be done automatically.

For platforms which do not act automatically, devices shall be provided to prevent the truck manoeuvring or travelling unless the operator is standing on the platform or the platform is in its upper rest position.

Travelling of more than 6 km/h shall only be possible when the platform is pivoted down and guards are in their protective position.

#### **4.7.3.4** *Stand-on platforms*

Operator stand-on platforms which are built within the plan view outline of pedestrian-controlled trucks, where the operator stands to the side of the motor housing, shall be equipped with an additional grab rail for operator stability when riding. This grab rail shall be capable of withstanding a horizontal force of 900 N applied in line with the operator's standing position, without permanent deformation. The requirements of **4.7.3.2** do not apply for this configuration of pedestrian-controlled truck.

#### **4.7.3.5** *Trucks with foldable platforms and foldable side guards*

On trucks with side guards and platforms of the folding or pivoting type as described in **4.7.3.2** and **4.7.3.3**, travelling movement shall only be possible when the side guard or platform is in a protective position or an inactive rest position. No travelling movement is allowed with the platform or side guard in an intermediate position.

#### **4.7.4** *Operator's Seat*

The seat shall be designed and located to provide easy access to the controls, shall provide a position for the truck operator in accordance with ergonomic principles and shall meet the following requirements:

- a) If the seat has a facility allowing fore and aft adjustment, this shall be possible without the use of tools;
- b) If a weight-adjustable seat is fitted to reduce vibration transmitted to the operator, the adjustment shall accommodate operator weights of 55 kg to 110 kg. Manual adjustment of the weight mechanism shall be possible without the use of tools;
- c) If a seat has a facility allowing it to swivel about a vertical axis, this shall be possible at all seat adjustment positions without unintentional operation of the controls;

- d) The seat mounting shall be able to withstand the forces which can occur during operation, for example, braking forces, as well as the forces imposed by the operator restraint specified in **4.7.8**;
- e) The requirements of **4.7.4(a)** to **4.7.4(d)**, above, also apply to additional operator's seats;
- f) When using an auxiliary seat on a stand-on industrial truck, a padded seat surface and backrest is sufficient. If the operating space of the stand-on operator is restricted, the auxiliary seat shall be capable of being folded or pivoted; and
- g) The seat anchorage to the battery cover or engine cover of sit-on counterbalanced trucks, as well as the latching method of the cover to the truck chassis, shall have sufficient strength in the event of a backwards tip-over of the truck from a loading dock. The seat anchorage shall be able to withstand a force of 2 250 N at a  $45^\circ \pm 5^\circ$  angle, as shown in Fig. 4.

Verification of this requirement shall be by means of a type test carried out using a strap wrapped around the seat as shown in Fig. 4.

The specification and marking of the operator's seat in accordance with ISO 7096 or EN 13490

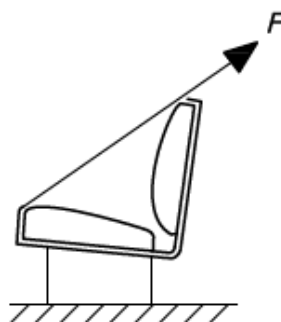

**Key**  
*F* force, 2 250 N

**FIG. 4 SEAT ANCHORAGE PULL TEST**

#### **4.7.5 Protection from Road Wheels and Objects Thrown Up By the Wheels**

##### **4.7.5.1 Ride-on trucks**

In the normal operating position, the operator shall be protected against contact with the truck wheels and against objects thrown up by the wheels (for example, mud, gravel, debris). The protection device for the steered wheels need only cover the wheels when in a straight-line position.

##### **4.7.5.2 Pedestrian-controlled trucks**

The operator in the normal operating position shall be protected against contact with the drive and stabilizing wheels. The position of these wheel protections shall be in accordance with Fig. 5.

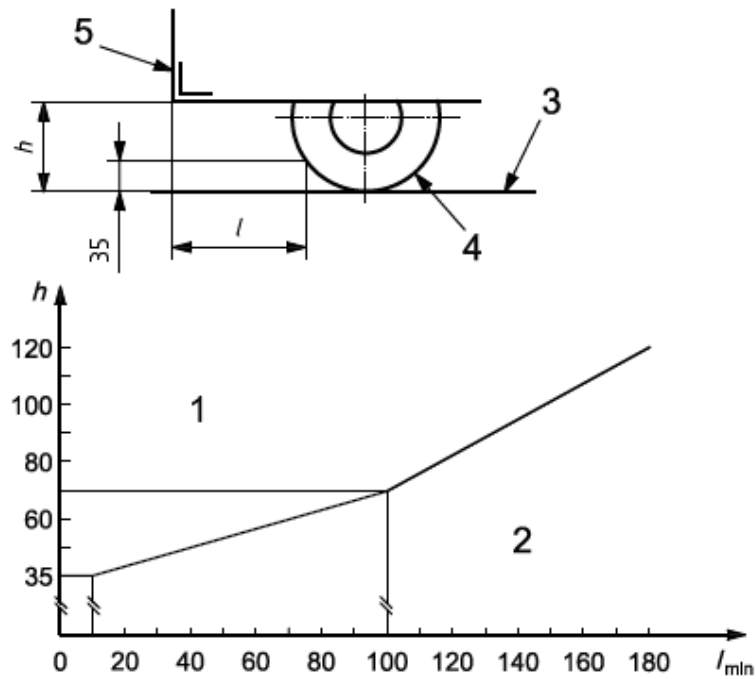

Either:

$$h < 35 \text{ mm}; l_{\min} = 10 \text{ mm}$$

Or:

$$h = 35 \text{ mm to } 70 \text{ mm}; l_{\min} = 2,57 \times h - 80 \text{ mm}$$

$$h = 70 \text{ mm to } 120 \text{ mm}; l_{\min} = 1,60 \times h - 12 \text{ mm}$$

All Dimensions in millimetres

FIG. 5 FREE SPACE FOR OPERATOR'S FEET

**Key**

- (1) = frame
- (2) = foot space
- (3) = ground/floor
- (4) = wheel
- (5) = frame edge
- (h) = height from ground or floor to frame edge
- (l) = horizontal distance from end of frame to point on wheel 35 mm above ground or floor

If, for pedestrian-controlled trucks, the driving and stabilizing wheel protection specified in 4.7.5.2 cannot be complied with, a wheel guard (deflector) as shown in Fig. 6 shall be installed. For castors, the deflector need only be mounted on the side on which the conditions specified in 4.7.5.2 are not met.

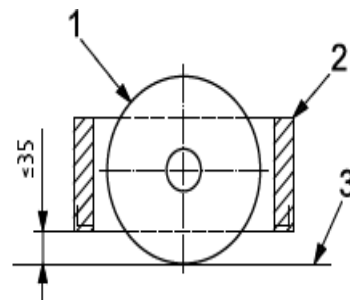

**Key**

- 1 wheel
- 2 deflector
- 3 ground (floor)

All Dimensions in millimetres

## FIG. 6 FOOT PROTECTION

### 4.7.6 Protection from Burning

All parts of the truck within reach of the operator in the normal operating position or when the operator is entering or leaving the operating position shall be insulated or shielded so that the surface temperature, generated by heat sources in the truck, of bare metal parts does not exceed 65 °C, and that of painted or plastic parts does not exceed 83 °C. The temperature of the air at the heater outlet, where fitted, shall not exceed 60 °C.

### 4.7.7 Protection against Crushing, Shearing and Trapping

#### 4.7.7.1 General

Parts that move relative to one another and that are within reach of the operator in the normal operating position shall be adequately guarded. If hazards still exist, they shall be identified according to **6.2** and on the truck in accordance with **6.3.3.4**.

Fixed Guards shall meet the requirements of EN 953 or ISO 14120.

When a fixed guard is removed, its fixing system shall remain on the guard or truck. This requirement applies to any fixed guards that are liable to be removed by the user with a risk or loss of the fixing, for example, fixed guards that are liable to be removed during routine maintenance or setting operations carried out at the place of use.

#### 4.7.7.2 Minimum distances

Parts separated by the following minimum distances satisfy the adequate guarding requirements of *clause 4.7.7.1*:

- a) Places where only the operator's fingers can be trapped: min. 25 mm;
- b) Places where only the operator's hands or feet can be trapped: min. 50 mm; and
- c) Places where the operator's arms or legs can be trapped: min. 100 mm.

Moving parts that need to be in contact with, or move in close proximity to, one another shall be guarded. Any openings in such guarding shall be small enough to prevent an 8 mm diameter probe from passing through them. If such hazards still exist, they shall be identified on the truck in accordance with **6.3.3.4**.

#### 4.7.7.3 Attachments

Crushing and shearing hazards to the operator in the normal operating position associated with attachments, except at the load supporting points, shall also meet the relevant requirements of **4.7.7.1**. If such hazards still exist, they shall be identified according to **6.2** and on the attachment by a warning sign in accordance with **6.3.3.4**.

#### 4.7.7.4 Foot protection

Trucks with a side-facing seated or standing operator shall be so built that when travelling, the operator cannot unintentionally place his feet outside the confines of the truck; or, alternatively, the truck shall be equipped with a traction cut off (for example, dead-man switch), enabled whenever an operator's foot is not in the safe guarded position.

#### **4.7.7.5** *Pedestrian and Stand-on end-controlled trucks with mast*

The mast shall be guarded at the side facing the operating controls, for example, by a transparent cover. The guard shall, as minimum, cover the whole width of the hazardous zone and the full length of the non-elevated mast, or up to 2.2m from the ground, whichever is less.

#### **4.7.8** *Operator Restraint*

Sit-on counterbalanced lift trucks with a rated capacity up to and including 10 000 kg and sit-on, single side-loading trucks shall have a restraint device, system or enclosure intended to reduce the risk of entrapment of the operator's head and/or torso between the truck and the ground in the event of a tip-over. Such means shall not unduly restrict the operation of the truck, for example, the operator's access, egress, and/or visibility.

Warnings and instructions on the purpose, use and action to be taken in the event of a tip-over, so as to reduce the risk associated with the operator's head impacting a solid surface, shall be provided on the truck and described in the instruction handbook (*see 6.2*). If a restraint system with a belt is used, this system shall be in accordance with ISO 24135-1.

#### **4.7.9** *Additional Operator Positions*

Additional operator position(s) shall be in accordance with **4.7.1** to **4.7.8**.

### **4.8** *Stability*

#### **4.8.1** *General*

In order to reduce the hazards of longitudinal and lateral tip-over in the operating conditions foreseen by the manufacturer, the trucks specified below shall comply with the stability requirements given in the applicable part of ISO 22915, without permanent deformation of the structure (*see 5.2*):

- (a) Basic test criteria and requirements for all applicable truck types, ISO 22915-1;
- (b) Counterbalanced trucks with mast, ISO 22915-2;
- (c) Reach and straddle trucks, ISO 22915-3;
- (d) Pallet stackers, double stackers and order-picking trucks with operator position elevating up to and including 1 200 mm lift height, ISO 22915-4;
- (e) Bidirectional and multidirectional trucks, ISO 22915-7;
- (f) Industrial variable-reach trucks, ISO 22915-11; and
- (g) Order-picking trucks with operator position elevating above 1 200 mm, ISO 22915-21.

NOTE — At the time of publication of this part of ISO 3691, other parts of ISO 22915 were planned or under preparation, applicable to the following types of industrial trucks: counterbalanced trucks with mast handling freight containers of 6m (20 ft) length and longer; industrial variable-reach trucks handling freight containers of 6m (20ft) length and longer; rough-terrain trucks with mast, rough-terrain variable-reach trucks; counterbalanced trucks with articulated steering; pedestrian-propelled trucks; burden and personnel carriers; lateral- and front-stacking trucks with elevating operator position.

The stability of trucks lifting less than 500 mm shall be tested according to the test requirements defined for travelling by the appropriate International Standard for stability for a similar truck design equipped with a mast.

NOTE — Taking into account the state of the art, it is not possible to meet the objectives for load control and load moment indicators.

NOTE — Stability for trucks rated capacity  $\geq 10000\text{Kg}$  shall be proved with the means of calculation, considering infrastructure required

#### **4.8.2** *Specific Operating Conditions*

For specific operating conditions foreseen by the manufacturer, additional stability tests shall be carried out in accordance with the following parts of ISO 22915, as applicable:

- (a) Trucks operating in the special condition of stacking with mast tilted forward and load elevated, ISO 22915-8;
- (b) Trucks operating in the special condition of stacking with load laterally displaced by powered devices, ISO 22915-10; and
- (c) Trucks operating in the special condition of offset load, offset by utilization, ISO 22915-20.

#### **4.8.3** *Levelling Indicator for Rough-Terrain Trucks*

Rough-terrain trucks shall be equipped with a levelling indicator to permit the operator in the operating position to keep the truck within the tilt limitations (for longitudinal and lateral axes) foreseen by the manufacturer.

### **4.9 Protective Devices**

#### **4.9.1** *Overhead Guard*

##### **4.9.1.1** *General*

Ride-on trucks with a maximum lift height of more than 1 800 mm above the floor shall be fitted with an overhead guard complying with ISO 6055, to protect the operator from falling objects.

Trucks with an elevating operator position up to and including 1 200 mm that feature a lift height of the load of more than 1 800 mm above the operator platform shall be fitted with an overhead guard complying with ISO 6055 to protect the operator from falling objects.

##### **4.9.1.2** *Additional fitting against falling small objects*

The overhead guard specified in **4.9.1.1** shall, when handling a load above 1 800 mm lift height, be constructed in such a manner that it can be provided with an additional fitting making it possible in those special cases to increase the protection of the operator against falling small objects.

##### **4.9.1.3** *Pedestrian-controlled trucks with foldable platform*

Pedestrian-controlled trucks with a foldable platform as specified in **4.7.3.3** shall be provided with means to prevent lifting over 1 800 mm from the floor when the side guards are in their protective position. This does not apply if an overhead guard as specified in **4.9.1.1** is fitted on the truck.

#### **4.9.2** *Load Backrest Extension*



#### **4.9.2.1** *Provision for load backrest extension*

Trucks fitted with fork arms with a lift height of more than 1 800 mm shall be designed so that they can be fitted with a load backrest extension.

#### **4.9.2.2** *Size of openings*

Load backrest extensions, if provided, shall have height, width, and size openings sufficient to minimize the possibility of the load falling toward the mast when the mast is in a position of maximum rearward tilt. The size of openings in the load backrest extension, if provided, shall not exceed 150 mm in one of the two dimensions.

#### **4.9.3** *Warning Device*

Trucks shall be equipped with an operator-controlled audible warning device.

#### **4.9.4** *Wheels with Split Wheel Rims for Inflatable Tyres*

When split wheel rims are used with pneumatic tyres, the truck shall be provided with means to prevent the user from separating the halves of the wheel before removing it from the axle. Information on the proper means of removing the tyre from the wheel shall be provided in the instruction handbook (*see 6.2*).

#### **4.9.5** *Traction Battery Compartment*

##### **4.9.5.1** *Unauthorized access*

On trucks with a nominal battery voltage exceeding 120 V D.C., if a lockable cover is not present on the battery enclosure, facilities shall be provided to enable the battery compartment to be secured so as to prevent unauthorized access to the battery.

##### **4.9.5.2** *Metal cover*

A metal cover for a battery compartment or battery enclosure shall have either:

- a) Sufficient strength and rigidity, in conjunction with an air spacing of at least 30 mm provided between it and the battery terminals, so that the battery terminals are not short-circuited when a 980 N force is applied to any area 300 mm 300 mm of the cover, or
- b) An air space reduced to a minimum of 10 mm, provided covers or live parts of the battery are insulated in such a way that disintegration and/or displacement of the insulation is prevented.

##### **4.9.5.3** *Non-metallic cover*

For non-metallic covers of battery compartments, the following applies:

- a) The cover shall have a burn rating of V0 or V1 in accordance with IEC 60695-11-10;
- b) The cover shall comply with an impact test of 136 J, the impact being produced by dropping a steel sphere having a diameter of 100 mm and mass of 4.11 kg from a height of 3.3 m. If the battery is located under an overhead guard, the impact may be reduced to 68 J, produced by dropping a steel sphere having a diameter of 100 mm and mass of 4.11 kg from a height of 1.65 m. There shall be no live parts exposed or impact that causes physical damage to the battery; and

c) If metallic parts project into the battery compartment, then **4.9.5.2** applies.

#### **4.9.5.4** *Ventilation*

The compartment and enclosure that houses a battery shall be provided with means for ventilation that reduce the likelihood of accumulation of explosive hydrogen-air mixture during truck operation.

When openings are positioned such that gases can escape freely, these shall be located away from the operator's position. Ventilation openings are usually satisfactory if they provide a cross-section, in square millimetres, equal to half the number of cells, multiplied by the rated capacity in Ampere-hours. This level of ventilation is not intended to cover the charging condition.

#### **4.9.5.5** *Resistance to electrolyte*

The battery enclosure, in accordance with ISO 20898, shall be resistant to the chemical effects of the electrolyte.

#### **4.9.6** *Battery-Restraint Devices*

On battery-powered trucks, means shall be provided to retain the battery from moving more than 15 mm in a horizontal direction.

In addition, on ride-on type trucks, where the displacement of the traction battery may pose a risk of injury to the operator due to a tip-over. A battery-restraint device(s) shall restrict the battery displacement to no more than 100 mm into the space normally occupied by the operator or from moving more than 100 mm in a lateral direction beyond the limits of the battery compartment. A tip-over may be simulated by allowing a static truck to fall free from its critical balance point impacting on a horizontal plane. A complete truck is not required for this test, but all battery compartment related parts shall be fitted. The movement of the battery shall not interfere with the operator's egress from the truck.

The battery housing shall be constructed, located and the battery installed so as to avoid electrolyte being spilled onto the operator in the event of tip-over and/or to avoid the accumulation of vapours in places occupied by the operator.

The battery cover, if any, of a compartment that is an integral part of the truck, or a separate enclosure such as a tray and cover, shall be secured.

#### **4.9.7** *Starter Battery Requirements*

The starter battery on engine-powered trucks shall be restrained from movement.

#### **4.9.8** *Handling of Batteries*

Battery-powered trucks should be designed such that batteries with a mass in excess of 25 kg can be easily removed using a means which supports the weight of the battery during removal, for example, an opening for slings in the overhead guard or rollers.

### **4.10** *Visibility and Lighting*

#### **4.10.1** *Visibility*

Requirements for all-round visibility from unladen trucks up to and including 10 000 kg rated capacity shall be in accordance with ISO 13564-1 except the following:

#### 4.10.1.1 *Travelling visibility*

When tested in accordance with 6.3.2 of IS 13564-1, in all positions along the test path, there shall be one or more illuminated areas for both requirements a) and b) of at least the following:

- a) Forward direction 25% of the vertical surface of test body and rearward directions 20 % of the vertical surface of the test body, as shown in Fig. 5 of ISO 13564-1;
- b) Forward direction: at least 20 % of any 500 mm X 500 mm surface on the test screen ( see 5.2 of ISO 13564-1) shall be illuminated, not considering the dark shadows cast by the vertical structural members of the mast (channels, I-beams and/or the vertical section of a telescopic boom).

NOTE 1— The dark shadows cast by these vertical structural members are included in **4.10.1.1 (a)**.

NOTE 2— Required minimum illuminated area of test surface given in Table 3 of ISO 13564-1 shall be 25% of the vertical surface of the test body.

For visibility with load, (*see 6.2.2*), considering that, if direct visibility is limited by the load, aids can be used.

NOTE — Visibility requirements for trucks over 10 000 kg were being developed at the time of publication of this part of ISO 3691.

#### 4.10.2 *Lighting*

Ride-on trucks shall be so designed that it is possible, referring to the manufacturer's instructions, to equip them with travel lights, working lights and signal lights.

### 4.11 **Environmental Conditions**

#### 4.11.1 *Operator's Cab*

##### 4.11.1.1 *General*

If a cab is fitted in lieu of an overhead guard, it shall comply with **4.9.1**.

##### 4.11.1.2 *Fire resistance*

All material and components of the cab shall be fire-resistant, with a maximum burning speed of 250 mm/min when the standard test piece is tested in accordance with ISO 3795.

##### 4.11.1.3 *Ventilation*

If a totally enclosed cab is fitted, provision shall be made for efficient ventilation.

##### 4.11.1.4 *Heater, demister and defroster*

If a totally enclosed cab is fitted with a heater/demister, the air intake should be connected to a fresh air inlet; recycling of the air is permissible. The heater shall be securely fixed. The heater shall be so designed

that the requirements of **4.7.6** can be met. A demist/defrost capability shall be provided for the windscreen and rear window.

#### **4.11.1.5** *Wipers and washers*

Windscreen wiper(s) and washer(s) shall be fitted to allow the operator a clear view of the operating area. Wiper(s) and washer(s) for the rear window may be omitted if the truck is driven predominantly in the forward direction, for example, tow tractors. Wiper(s) and washer(s) may be omitted entirely if the truck only operates within an enclosed area. If glass is used in the window apertures, it shall be toughened or laminated.

#### **4.11.1.6** *Access and emergency exit*

The cab shall have an access and an emergency exit complying with ISO 2867. The emergency exit, which may be a window, shall allow escape in a different direction than that of the normal exit.

#### **4.11.1.7** *Storage of instruction handbook*

Provision shall be made for the storage of the instruction handbook (*see 6.2*) so that it does not obstruct the normal operating position.

#### **4.11.1.8** *Additional operator's position*

If an additional operator's position is equipped within a cab, it shall meet the requirements of **4.11.1.1** to **4.11.1.6**.

### **4.11.2** *Noise Emissions*

#### **4.11.2.1** *General*

Industrial trucks shall be designed and constructed such that risks resulting from the emission of airborne noise are reduced according to the state of the art.

When noise is a significant hazard, there is need for a low-noise design. In this case, the methodology for low-noise design given in ISO 11688-1 shall be considered.

NOTE — ISO 11688-2 gives useful information on noise-generation mechanism in machinery

Normally, noise is not a significant hazard for battery powered trucks

#### **4.11.2.2** *Main source of Noise*

On industrial trucks, the main sources of noise are components, such as the following, in a high-speed operation mode:

- a) Combustible engines, including air intake, cooling fan and exhaust system; and
- b) Hydraulic pumps/motors

#### **4.11.2.3** *Measure to reduce noise at the operator's position*

Typical measures to reduce noise including the following:

- a) Selection of low-noise components;
- b) Use of elastic mountings that prevent the transmission of structure-borne noise from the components to the structures; and
- c) The use of improved noise insulated in the cabin, if fitted.

These and other measures of identical or better efficiency may be used.

#### **4.11.2.4** *Determination of noise emission values*

The values of noise emissions shall be measured using the test method given in EN 12053. Value shall be communicated to customer and user.

#### **4.11.3** *Vibration*

Whole-body vibrations transmitted to the operator are subject to shall be measured using the test method given in EN 13059. Value shall be communicated to customer and user.

#### **4.11.4** *Electromagnetic Compatibility (EMC)*

EMC test is subject to the need of customer. If applicable, it shall comply with EN 12895.

#### **4.11.5** *Transport*

##### **4.11.5.1** *Location for lifting and/or slinging points*

When a truck can be lifted without disassembling, locations for lifting and/or slinging points shall be provided and shall be indicated on the truck and/or in the instruction handbook (*see 6.2*).

When individual assemblies of the truck can be removed for normal operation and/or transport, then lifting and/or slinging points shall be provided and these shall be indicated on the assemblies and/or in the instruction handbook.

Slinging points for transportation of the truck shall be arranged such that there is no possibility of sudden movement.

##### **4.11.5.2** *Tie-down points*

Tie-down points for transportation of the assembled truck shall be provided and indicated on the truck or in the instruction handbook (*see 6.2*).

##### **4.11.5.3** *Slinging of removable attachments*

Locations for the slinging of a removable attachment shall be provided and shall be indicated on the attachment (*see 6.3.1.2*) and/or in the instruction handbook.

Slinging points for transportation of the attachment shall be arranged such that there is no possibility of sudden movement.

#### 4.12 *Devices for Towing*

Trucks used for towing trailers shall be fitted with towing or coupling devices designed, constructed and arranged to reduce hazards of connection and disconnection and to prevent accidental disconnection during use.

### 5 VERIFICATION OF SAFETY REQUIREMENTS AND/OR PROTECTIVE MEASURES

#### 5.1 General

The manufacturer shall have verification that the safety requirements and/or protective measures given in 4 have been incorporated into the design and manufacture of the truck. Either one or a combination of the following shall be used to achieve verification:

- a) By design, for example, verification of drawings and documents, or calculation;
- b) By measurement, for example, tests of travelling and lowering speed or lift and tilt leakage;
- c) By visual examination, for example, no permanent deformation after tests, verification of the marking of the truck; and
- d) By further testing.

#### 5.2 Structural Tests

These tests are to be performed on a sample that is representative of series production. The structural components of the truck and its attachments shall carry static loads of  $1.33 Q_1$  and  $1.33 Q_2$  for 15 min each, where,

$Q_1$  = rated capacity at the standard lift height and standard load centre distance in accordance with the information on the capacity plate; and

$Q_2$  = actual capacity at maximum lift height in accordance with the information on the capacity plate.

The truck shall be on substantially level ground with the mast in the substantially vertical position and may be anchored to prevent tip-over.

The loads may be applied at the corresponding height by means independent of the truck. The test shall not result in any visual permanent deformation or damage.

#### 5.3 Functional Verification

Functional verification shall be carried out on each truck to verify that it is able to perform the tasks for which it was designed. These tests shall be done according to the manufacturer's instructions. They shall be performed by trained persons either operating and testing the truck according to the manufacturer's instructions or simulating these tests by any method giving an equivalent effect and producing substantially the same result.

Each truck shall be inspected to ensure that the travelling, braking, steering, load-handling controls and combined functions, if any, are appropriately identified and operate correctly. The correct operation of warning devices, safety devices and lighting, if any, shall also be checked.

## 5.4 Acceptance Criteria

Each truck shall be tested as per respective IS standard for regular production.

- (a) IS 10517 – Acceptance criteria for forklift trucks
- (b) IS 11757 - General requirements and acceptance criteria for forklift trucks with capacity from 10 000 kg to 50 000 kg
- (c) IS 10311 - General requirements of powered platform trucks and their acceptance criteria
- (d) IS 10312 - Safety code for powered tow trucks

## 6 INFORMATION FOR USE

### 6.1 General

Each truck and removable attachment shall be supplied to the user with an instruction handbook(s), covering operating and regular servicing and addressing all identified hazards, printed in the language(s) of the country in which the truck is to be used, where required by national law. See also 6.4.5 of ISO 12100,.

There is no need for the workshop and parts handbooks intended for use by specialized personnel employed by the manufacturer or his authorized representative to be supplied with each truck, and these can be printed in the language of the country where the truck is to be used, as required by national law. In other cases, the instructions shall be in a language agreed between the truck supplier and purchaser.

### 6.2 Instruction Handbook

#### 6.2.1 *Truck/Attachments*

The instruction handbook(s) shall include, as applicable, at least the following information:

- a) Name and address of the manufacturer or authorized representative;
- b) Designation of type, for example, counterbalanced, side-loading truck;
- c) Description of the truck and accessories;
- d) Attachments supplied with the truck and their assembly precautions;
- e) Details of use of a removable load backrest extension;
- f) Details for the installation of a fire extinguisher, if required by the application of the truck;
- g) Admissible wheel rims and tyres with inflation pressures for pneumatic tyres;
- h) Description of safety devices and warning labels;
- j) Information on stability;
- k) The noise value in accordance with EN 12053;
- m) The vibration value in accordance with EN 13059; and

- n) The static test coefficient used for the lifting accessory.

### 6.2.2 *Operation of Truck*

The instruction handbook(s) shall include, as applicable, at least the following information:

- a) Intended uses of the truck and attachments, and examples of hazardous misuse;
- b) Training requirements for the operator;
- c) Function of operating controls and displays;
- d) Pre-shift checks before the truck is put into operation;
- e) Instructions for adjustment of the operator's seat;
- f) Instructions for operation with/without cab, with/without doors;
- g) Instructions for access and egress;
- h) Instructions for safe handling by the operator, for example, when changing attachments or moving fork arms;
- j) Requirements of the ground/floor where the truck is to be used;
- k) Instructions for starting, driving and stopping the truck;
- m) Instructions for handling loads, warning about the hazards due to the action of wind forces;
- n) Instructions when operating on a gradient;
- p) Instructions for towing the truck;
- q) Instructions for parking the truck;
- r) Warning of risks during the use of the truck and its attachments, including crushing and shearing hazards;
- s) Climatic conditions in which the truck is designed to operate;
- t) Instructions about the direction of turning of the truck in relation to rotation of the steering wheel forend-controlled trucks;
- u) Instructions about operating the truck with loads causing insufficient visibility;
- v) Instructions on the use of any visual aid that may be provided;
- w) Instructions and conditions for the use of the drawbar;
- y) Instructions when operating a rear touch device;
- z) Instructions or instructions on action to be taken in the event of a malfunction;



- aa) Instructions for operation of the truck by a remote-control device, for example, visibility;
- bb) The normal operating conditions as defined by the manufacturer, for example, those for which the truck has been designed and the manner in which the truck will be used;
- cc) Instructions on the use of the operator-restraint device, system or enclosure, and guidance on the operator's behaviour in the event of a tip-over;
- dd) Information about lighting of the working area;
- ee) The procedure for movement of inoperative trucks;
- ff) Instructions against operating truck with guarding removed;
- gg) Lift height for travelling;
- hh) Crushing and shearing hazards for the operator of pedestrian-controlled trucks featuring foldable platforms and reach trucks, between parts of the environment and the truck during travelling forward;
- jj) Instructions to the operator of a stand-on end-control truck to step off and away from the truck in the event of a tip-over or off-dock accident;
- kk) Information and instructions for using attachments, for example, load bearing clamp; and
- mm) Information about specific protective devices ( for example, protective screen) and their use.

### **6.2.3** *Details for Battery-Powered Trucks*

The instruction handbook(s) shall include, as applicable, at least the following information:

- a) Specification of approved batteries and on-board battery chargers;
- b) Procedure for safe handling of batteries, including installation, removal and secure mounting on the truck;
- c) Warning of risks of accumulation of hydrogen under covers;
- d) Battery charging procedures and instructions; and
- e) Service mass of battery and ballast when required.

### **6.2.4** *Details for Internal-Combustion-Engine Powered Trucks*

The instruction handbook(s) shall include at least the following information:

- a) Approved fuels;
- b) Procedure for safe handling of fuels;
- c) Procedure for refuelling;
- d) Warning of the effect of exhaust emissions in confined spaces; and

- e) Warning of the effect of exhaust emissions for the operator.

#### **6.2.5 Service and Maintenance**

The instruction handbook(s) shall include, as applicable, at least the following information:

- a) Training and qualifications needed for service and maintenance staff;
- b) Safe procedure for the identification, detection and correction of faults;
- c) Instructions for changing tyres or wheels;
- d) Instructions for verification that markings, for example, decals, are in place and legible;
- e) Instructions for de-energizing of stored energy components;
- f) Access to maintenance while working at height;
- g) Servicing operations for which no specific skills are required;
- h) Use of approved spare parts;
- j) Drawings and diagrams necessary for truck service and maintenance;
- k) Instructions for disposing of waste material (for example, oils and battery);
- m) Type and frequency of inspections and maintenance operations, with particular attention to thereplacement and durability of wear and serviceable parts, emissions, and to the user's logbook (for example, filter, brakes, chains, hydraulic hoses);
- n) Instructions for removing and reattaching guarding;
- p) Instructions for regular verification of seat belt related to
  - (1) Cut or frayed straps;
  - (2) Worn or damaged hardware, including anchor points;
  - (3) Buckle or retractor malfunction; and
  - (4) Loose stitching.

#### **6.2.6 Transportation, Commissioning and Storage**

The instruction handbook(s) shall include, as applicable, at least the following information:

- a) Mass and overall dimensions of the truck and dismantled parts for transport, commissioning and storage;
- b) Procedures for transporting, including loading and unloading;
- c) Procedure for truck reassembly and mounting of attachments;

- d) Functional tests on completion of commissioning;
- e) Procedure for movement of inoperative trucks;
- f) Procedure for prolonged shut down and storage of trucks; and
- g) The procedure for truck mounting.

### **6.2.7 Truck Modification**

**6.2.7.1** Unauthorized truck modification is not permitted. The text of **6.2.7.3** shall be included in the instruction handbook and the workshop handbook.

**6.2.7.2** Except where provided in **6.2.7.3**, no modifications or alterations to a powered industrial truck, which could affect, for example, capacity, stability or safety requirements of the truck, shall be made without the prior written approval of the original truck manufacturer, its authorized representative, or a successor thereof. This includes changes affecting, for example, braking, steering, visibility and the addition of removable attachments. When the manufacturer or his successor approves a modification or alteration, the manufacturer or successor shall also make and approve appropriate changes to the capacity plate, decals, tags and operation and maintenance handbooks.

**6.2.7.3** Only in the event that the truck manufacturer is no longer in business and there is no successor in the interest to the business, may the user arrange for a modification or alteration to a powered industrial truck provided however, that the user:

- a) Arranges for the modification or alteration to be designed, tested and implemented by an engineer(s) expert in industrial trucks and their safety,
- b) Maintains a permanent record of the design, test(s) and implementation of the modification or alteration,
- c) Approves and makes appropriate changes to the capacity plate(s), decals, tags and instruction handbook, and
- d) Affixes a permanent and readily visible label to the truck stating the manner in which the truck has been modified or altered, together with the date of the modification or alteration and the name and address of the organization that accomplished those tasks.

## **6.3 Marking**

### **6.3.1 Information Plates**

#### **6.3.1.1 Trucks**

Trucks shall be marked legibly and indelibly (for example, weather-proofed, profiled letters) with at least the following details:

- a) Name and address of the manufacturer or his authorized representative;
- b) Designation of series or type and compliance with the requirements of this part of ISO 3691;
- c) Serial number and year of manufacture;

- d) Unladen mass of the truck in working order and without removable attachments, and without battery in the case of battery-powered trucks, but with fork arms or integral attachments, the actual mass being permitted to vary from the stated mass by up to 5 % or 1 000 kg, whichever is the lower of the two;
- e) Actual capacity at maximum lift height with load centre distance; where a secondary lift is fitted to a truck, the capacity at maximum lift shall be determined with the secondary mast fully elevated;
- f) Actual capacities at other lift heights and load centre distances, if applicable;
- g) Actual capacity with each removable attachment fitted at the manufacturer's authorized lift height(s) and load centre(s), these actual capacities being easily readable by the operator in the normal operating position;
- h) On battery-powered trucks, the authorized maximum and minimum battery mass and the system voltage;
- i) If fitted, the maximum supporting force on the towing point connection, in newtons;
- j) If fitted, the drawbar pull on the towing point connection, in newtons; and
- k) The nominal power in kilowatts, for example, marked on the engine or electric motor.

#### **6.3.1.2 Removable attachments**

Removable attachments shall be marked legibly and indelibly (for example, weather-proofed, profiled letters) with at least the following details:

- a) Name and address of the attachment manufacturer or his authorized representative;
- b) Model or type;
- c) Serial number and year of manufacture;
- d) Mass of attachment, which may vary from the stated figure by up to 5 % or 200 kg, whichever is the lower of the two;
- e) Distance of the centre of gravity of the attachment from its mounting face on the truck;
- f) Rated capacity;
- g) In the case of hydraulically or pneumatically operated attachments, the maximum operating pressure recommended by the attachment manufacturer;
- h) Load centre, if applicable;
- j) Lost load centre distance; and
- k) The instruction. The capacity of the truck and attachment combination shall be complied with.

#### **6.3.1.3 Tractors**

Tractors shall be marked legibly and indelibly (for example, weather-proofed, profiled letters) with at least the following details:

- a) Name and address of the manufacturer or the authorized representative;

- b) Designation of series or type;
- c) Unladen mass of the tractor in working order without battery for battery-powered tractors; the mass may vary from the figure shown by up to 5 % or 1 000 kg, whichever is the lower;
- d) Serial number and year of manufacture;
- e) On battery-powered tractors, the authorized minimum and maximum battery mass and the system of voltage;
- f) The nominal power in kilowatts, for example, marked on the engine or electric motor;
- g) The maximum supporting force on the tow-hook, in newtons;
- h) The drawbar pull, in newtons, and the period of time during which this pull can be exerted.

#### **6.3.1.4** *Marking of controls*

Controls shall be legibly and indelibly marked (for example, weather-proofed, profiled letters) with graphic symbols indicating the function(s), except where these are obvious, for example, accelerator pedal. Each symbol shall be affixed on, or in close proximity to, the control to which it applies. Control symbols shall comply with ISO 3287, for existing symbols.

#### **6.3.2** *Information Plate for Trucks Operating in Special Conditions*

If a truck is designed to operate in special conditions (*see 4.1.1 and 4.8.2*), the manufacturer shall provide, where appropriate, and in addition to the information provided in the instruction handbook, an information plate on the truck identifying those special conditions of use, including capacity if different from the capacity during normal operation (*see 4.1.2*).

#### **6.3.3** *Other Information*

##### **6.3.3.1** *Marking for Slings of Trucks*

Locations for slinging shall be clearly indicated on the truck or shall be declared in the instruction handbook (*see 6.2*).

##### **6.3.3.2** *Pneumatic tyre inflation pressure*

The specified inflation pressures shall be clearly indicated on the truck.

##### **6.3.3.3** *Filling points*

Filling points for fuel and hydraulic fluid shall be clearly indicated on the truck in accordance with ISO 3287.

##### **6.3.3.4** *Warning signs*

Symbols giving warnings of remaining hazards shall be affixed to the truck and attachments on, or in close proximity to, the hazard concerned. On stored energy devices (*see 4.1.6*), a warning label and the method for removing any stored energy shall be affixed to that component and noted in the service handbook. Warnings shall be in accordance with ISO 15870.

#### **6.3.4** *Languages*

If any of the information in **6.3.1** to **6.3.3** is in words, it shall be written in the language(s) of the country in which the truck is to be used, in accordance with national law. In other cases, the instructions shall be in a language agreed between the truck supplier and purchaser.

#### **6.3.5** *Operator Restraint*

Information or symbols giving instructions for the use of the operator restraint system or enclosure shall be easily readable by the operator in the normal operating position.

**ANNEX A**  
(Normative)

**DETERMINATION OF DRIVING DIRECTION AND RATED CAPACITY**

**A-1 FORWARD-DRIVING DIRECTION**

The forward-driving or forward direction is dependent on the type of truck.

- a) For sit-on trucks where the operator is facing the line of travel, load leading is the forward direction.
- b) For sit-on trucks where the operator is facing approximately at a right angle to the line of travel, load trailing is the forward direction.
- c) For side-loading trucks (one side only) where the operator is facing towards the line of travel, the direction in which the operator is facing is the forward direction.
- d) For side-loading trucks (one side only) where the operator is facing approximately at right angles to the line of travel, the forward direction is the end at which the operator is positioned.
- e) For trucks with an elevated operator position, the forward direction is the direction in which the operator is oriented when facing the travel controls.
- f) For pedestrian-controlled trucks and low-lift order-picking trucks, load trailing is the forward direction.
- g) For stand-on, end-controlled trucks where the operator is facing the line of travel, load leading is the forward direction.
- h) For stand-on, end-controlled trucks where the operator is facing at a right angle to the line of travel, the travel direction is defined only by load trailing or load leading.

**A-2 RATED CAPACITY**

**A-2.1 Specification**

**A-2.1.1 High-Lift Trucks with Masts**

For the rated load,  $Q$ , the following conditions apply (see Fig. 7):

- a) Load centre of gravity,  $G$ , positioned at the standard load centre distance,  $D$  (see A.2.3);
- b) Load  $Q$  vertically lifted to the standard lift height,  $H$  (see A.2.2); and
- c) A truck equipped with a two-stage mast that has a maximum lift equal to the standard lift height.

When the truck does not utilize a two-stage mast, it should be given a rated capacity at the standard lift height as if the mast were available.

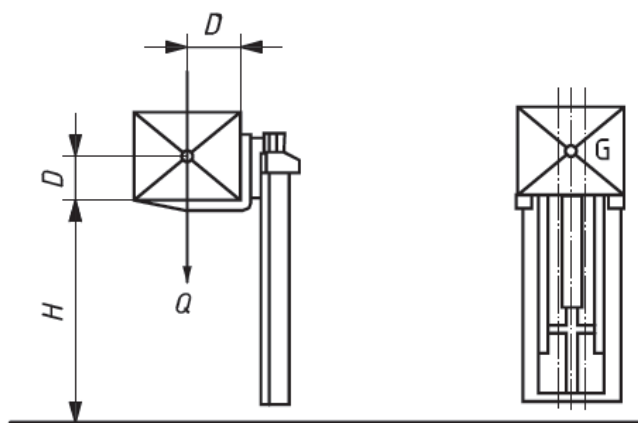
**Key**

- $D$  standard load centre distance
- $G$  load centre of gravity, positioned in the longitudinal plane of symmetry between the mast uprights
- $H$  standard lift height
- $Q$  rated load

FIG. 7 RATED LOAD CONFIGURATION

#### A-2.1.2 Pedestrian-Controlled, Pallet-Stacker Trucks

For the rated load,  $Q$ , the following conditions apply (see Fig. 7):

- a) Load centre of gravity,  $G$ , positioned at the standard load centre distance,  $D$  (see A-2.3); and
- b) Load  $Q$  vertically stacked to the standard lift height,  $H$  (see A-2.2).

#### A-2.1.3 Pedestrian-Controlled Scissor-Lift Pallet Trucks

For these trucks, the maximum load, given by the manufacturer, expressed in kilograms and uniformly distributed over the length of the fork arms, is the load that the truck is capable of carrying and lifting in normal operation.

#### A-2.1.4 Low-Lift-Height and Fixed-Platform Trucks

For these trucks, the maximum load, given by the manufacturer, expressed in kilograms and uniformly distributed over the load-carrying platform or device is the load that the truck is capable of carrying and — if applicable — lifting in normal operation.

#### A-2.1.5 Removable Attachments

For such attachments, the maximum load, in kilograms, at a specified load centre that the attachment is capable of handling in normal operation is as specified by the attachment manufacturer.

### A-2.2 Standard Lift Height, $H$

Standard lift height values, expressed in millimeters, are measured from the ground to the upper face of the fork blades or lifting platform, and are as follows for the trucks covered by this part of ISO 3691:

- a) For pallet-stacking trucks and high-lift platform trucks below 1 000 kg rated load having a width across fork arms or platform up to and including 690 mm, and for counterbalanced trucks below 1 000 kg rated load,  $H = 2\,500$  mm;



- b) For all other types of trucks, up to and including 10 000 kg rated load,  $H = 3\,300$  mm;
- c) For all other types of trucks, above 10 000 kg rated load,  $H = 5\,000$  mm.

### A-2.3 Standard Load Centre Distance, $D$

Distance  $D$ , expressed in millimeters, is measured from the centre of gravity  $G$ , of the load measured horizontally to the front face of the fork arm shank and vertically to the upper face of the fork arm blade.

- For counterbalanced trucks, the values of  $D$  are according to Table 2;

**Table 2**

Rated load, $Q$ kg		Standard load centre distance, $D$ mm				
		400	500	600	900	1 200
0	< 1 000	X		X <sup>a</sup>		
≥ 1 000	< 5 000		X	X <sup>b</sup>		
≥ 5 000	≤ 10 000			X	X	
> 10 000	< 20 000			X	X	X
≥ 20 000	< 25 000				X	X
≥ 25 000						X

<sup>a</sup> 600 mm is used in the USA.

<sup>b</sup> 600 mm is used in the USA, Asia and Australia.

- For single side-loading trucks and lateral- and front-stacking trucks,  $D$  is as specified by the manufacturer;
- For trucks where the load centre distances differ from those specified in Table 2 for special applications, the respective rated capacity should be defined; and
- For all other types of trucks, up to and including 10 000 kg rated load,  $D = 600$  mm.

NOTE — Some Asian countries use a load centre distance of 500 mm for reach trucks and high-lift order-picking trucks with a rated capacity up to and including 3 000 kg.

### A-3 RATED DRAWBAR PULL OF TRACTORS

The horizontal drawbar pull at the coupling, in newtons, given by the manufacturer, is that which the industrial tractor can develop at a specified coupling height while travelling on a smooth, dry and horizontal concrete surface as follows:

- a) For tractors powered by an internal combustion engine, while moving at a uniform speed of not less than 10 % of the rated no-load speed; and
- b) For battery-powered tractors, that which can be sustained continuously for a period of 1 h.

For ride-on tractors the rated drawbar pull should be established using an operator mass of 90 kg (ballasted accordingly).

The requirements for the quality of the driving surface can differ for the floor used indoors and outdoors. This floor quality depends on the operating conditions of the tractor, and these conditions should be specified in the instruction handbook [*see 6.2.2 (i)*].

**ANNEX B**  
(Informative)

**LIST OF SIGNIFICANT HAZARDS**

This list contains all the significant hazards, hazardous situations and events, as far as they are dealt with in this part of ISO 3691, identified by risk assessment of industrial trucks and which require action to eliminate or reduce the risk, *see* Table 3.

NOTE — The structure of the table is based on that of ISO 14121-1, Table 2. The order of lines within a group corresponds to the truck functionalities.

**Table 3 List of Significant Hazards**

Sl. No.	Type or Group/Origin	Potential Consequences	Corresponding Requirement	
<b>1</b>	<b>Mechanical hazards</b>			
	<ul style="list-style-type: none"> <li>- Acceleration, deceleration (Kinetic energy)</li> <li>- Machinery Mobility</li> <li>- Moving element</li> <li>- Rotating element</li> </ul>	<ul style="list-style-type: none"> <li>- Being run over</li> <li>- Crushing</li> <li>- Drawing-in or trapping</li> <li>- Impact</li> </ul>	4.1.4	Electrical requirements
			4.1.6	Stored energy components
			4.2	Starting/moving
			4.3	Brakes
			4.4	Manual control actuators
			4.6.2.2	Failure of lifting/lowering mechanism
			4.6.2.3	Lowering speed
			4.6.3	Hydraulic lifting and tilting system
			4.6.4.3	Failure of energy supply to hydraulic circuit
			4.6.4.4	Fluid purification
			4.6.5	Load handling and stacking attachments
			4.7.3	Platform
			4.7.4	Operator's seat
			4.7.5.2	Protection from road wheels/pedestrian –controlled truck
			4.9.3	Warning Device
			4.9.6	Battery restrain devices
			4.9.7	Starter battery requirements
			4.7.8	Operator restrain
				5
		6	Information for use	
	<ul style="list-style-type: none"> <li>- Angular parts</li> <li>- Approach of a moving element to a fixed part</li> <li>- Cutting parts</li> <li>- Sharp edges</li> </ul>	<ul style="list-style-type: none"> <li>- Crushing</li> <li>- Cutting or severing</li> <li>- Drawing-in or trapping</li> <li>- Entanglement</li> </ul>	4.1.5	Edges & angles
			4.1.6	Stored energy components
			4.2	Starting/moving/Travel controls/pedestrian-controlled trucks
			4.4.2.6	Additional operation from outside the truck
			4.4.2.7	Additional operation from alongside pedestrian-controlled and stand-on

Sl. No.	Type or Group/Origin	Potential Consequences	Corresponding Requirement	
		- Shearing - Stabbing or puncture		trucks (coasting)
			4.5.3	Access to engine and other compartments
			4.7	Operator position
			4.7.5	Protection from road wheels and objects thrown up by the wheels
			4.7.7	Protection against crushing, shearing and trapping
			4.7.9	Additional operator positions
			4.9.6	Battery-restrain device
			4.12	Devices for towing
			6	Information for use
	- Elastic elements	- Crushing - Impact - Cutting and severing - Shearing - Stabbing or puncture	4.1.6	Stored energy components
			4.9.4	Wheels with split wheel rims for inflatable tyres
			6	Information for use
	- Falling objects	- Crushing - Impact	4.4.4	Load Handling controls
			4.6	Systems for lifting and tilting
			4.8	Stability
			4.9.1	Overhead Guard
			4.9.2	Load backrest extension
			4.11.1.1	Operator's cab / General
			4.11.5	Transport
			5	Verification of safety requirements and/or protective measures
			6	Information for use
	- Gravity (Stored Energy)	- Crushing - Impact	4.4.4	Load-handling controls
			4.6	Systems for lifting and tilting
			4.9.1	Overhead guard
			4.9.2	Load backrest extension
			4.11.1.1	Operator's cab/General
			5	Verification of safety requirements and/or protective measures
			6	Information for use
	- Heights from the ground	- Being thrown - Crushing - Drawing-in or trapping - Impact - Slipping, tripping and falling	4.6	Systems for lifting and tilting
			4.7.1	Operator position/Dimension
			4.7.2	Operator access and egress
			4.7.3	Platforms
			4.8	Stability
			5	Verification of safety requirements and/or protective measures
			6	Information for use
	- High Pressure	- Injection	4.1.6	Stored energy components
			4.5.4	Liquefied petroleum gas (LPG)-

Sl. No.	Type or Group/Origin	Potential Consequences	Corresponding Requirement	
				powered trucks
			4.6.4	Hydraulic systems
			5	Verification of safety requirements and/or protective measures
			6	Information for use
	- Rough, slippery surface	- Slipping, tripping and falling	4.7.2.2	Steps
			4.7.2.3	Compartment floors
	- Stability	- Being thrown	4.4.4	Load-handling controls
		- Crushing	4.6	Systems for lifting and tilting
		- Impact	4.8	Stability
			4.11.5	Transport
			5	Verification of safety requirements and/or protective measures
			6	Information for use
<b>2</b>	<b>Electrical Hazards</b>			
	- Arc	- Burn	4.1.4	Electrical requirements
	- Electromagnetic Phenomena	- Chemical effects	4.9.5.1	Traction battery compartment/unauthorized access
	- Electrostatic phenomena	- Electrocutio n	4.9.5.2	Metal cover
	- Live parts	- Falling, being thrown	4.11.4	Electromagnetic compatibility
	- Not enough distance to live under high voltage	- Fire	5	Verification of safety requirements and/or protective measures
	- Overload	- Projection of molten particles	6	Information for use
	- Parts which have become live under fault conditions	- Shock		
	- Short-circuit			
	- Thermal radiation			
<b>3</b>	<b>Thermal hazards</b>			
	- Explosion	- Burn	4.1.2	Normal climatic condition
	- Flame	- Dehydration	4.1.4	Electrical requirements
	- Objects or materials with a high or low temperature	- Discomfort	4.3	Brakes
	- Radiation from heat sources	- Frostbite	4.5.1	Exhaust and cooling systems
		- Injuries by the radiation of heat sources	4.5.2	Fuel tank
		- Scald	4.5.4	Liquefied petroleum gas (LPG)-powered trucks
			4.7.6	Protection from burning
			4.9.5	Traction battery compartment
			4.11.1.2	Operator's cab/Fire resistance
			4.11.1.4	Heater, demister and defroster
			5	Verification of safety requirements and/or protective measures
			6	Information for use
<b>4</b>	<b>Noise hazards</b>			
	- Exhausting	- Discomfort	4.11.2	Noise emissions

Sl. No.	Type or Group/Origin	Potential Consequences	Corresponding Requirement	
	system - Moving parts	- Loss of awareness - Loss of balance - Permanent hearing loss - Stress - Tinnitus - Tiredness		
<b>5</b>	<b>Vibration hazards</b>			
	- Mobile equipment	- Discomfort - Low-back morbidity - Neurological disorder - Osteo-articular disorder - Trauma of the spine - Vascular disorder	4.11.3	Vibration
<b>6</b>	<b>Radiation hazards</b>			
	No origin of these kinds of hazards in industrial trucks covered by this part of ISO 3691.			
<b>7</b>	<b>Material/Substance hazards</b>			
	- Combustible - Explosive - Flammable - Fluid - Fume - Gas	- Breathing difficulties, suffocation - Cancer - Corrosion - Effects on reproductive capability - Explosion - Fire - Infection - Mutation - Poisoning - Sensitization	4.1.4 4.5.2.1 4.5.2.2 4.5.4 4.9.5.4 4.11.1.3 6	Electrical requirements Tank isolation Fuel spillage Liquefied petroleum gas (LPG)-powered trucks Traction battery compartment/Ventilation Operator's cab/Ventilation Information of use
<b>8</b>	<b>Ergonomic hazards</b>			
	- Access - Design or location of indicators and visual display unit	- Discomfort - Fatigue - Musculoskeletal disorder	4.1.2 4.1.4 4.4 4.5.1 4.7.1	Normal climatic conditions Electrical requirements Manual control actuators Exhaust and cooling system Operator position/Dimensions

Sl. No.	Type or Group/Origin	Potential Consequences	Corresponding Requirement	
	<ul style="list-style-type: none"> <li>- Design, location or identification of control devices</li> <li>- Effort</li> <li>- Local lighting</li> <li>- Mental overload/underload</li> <li>- Posture</li> <li>- Repetitive activity</li> <li>- Visibility</li> </ul>	<ul style="list-style-type: none"> <li>- Stress</li> <li>Any other (for example, mechanical, electrical) as a consequence of human error</li> </ul>	4.7.2	Operator access and egress
			4.7.3	Platform
			4.7.4	Operator's seat
			4.10	Visibility/Lighting
			4.11.1	Operator's cab
			6	Information for use
<b>9</b>	<b>Hazards associated with environment in which the machine is used</b>			
	<ul style="list-style-type: none"> <li>- Dust and fog</li> <li>- Electromagnetic disturbance</li> <li>- Lightning</li> <li>- Moisture</li> <li>- Temperature</li> <li>- Water</li> <li>- Lack of oxygen</li> </ul>	<ul style="list-style-type: none"> <li>- Burn</li> <li>- Slight disease</li> <li>- Slipping, falling</li> <li>- Suffocation</li> <li>Any other as a consequence of the effect caused by the sources of the hazards on the machine or parts of the machine</li> </ul>	4.1.2	Normal climatic conditions
			4.10	Visibility/Lighting
			6	Information for use
<b>10</b>	<b>Combination of hazards</b>			
	For example, repetitive activity + effort + high environmental temperature	For example, dehydration, loss of awareness, heat stroke	4.1.2	Normal climatic conditions
			6	Information for use